

TCAEY-THAEY 4160÷4320

Y-Pack range



MacroSystem
138÷325 kW
160÷342 kW



Packaged air-cooled reversible water chillers and heat pumps with axial fans.

Range with hermetic Scroll compressors and R410A refrigerant gas.

R410A



CE



Contents

General Features	4
Intended Conditions of Use	4
New Y-Pack series	5
Energy-saving, reliable and versatile water chillers and heat pumps	5
AdaptiveFunction Plus	6
TCAEBY TCAETY TCAESY TCAEQY THAETY THAESY Models 4160-4320	8
Construction features	8
Versions	8
Potential installations	8
Electrical board	8
Accessories	9
Factory fitted accessories	9
Accessories supplied loose	9
Technical data	10
Energy efficiency at partial loads - ESEER index	16
Electronic controls	17
Electronic control	17
KTR – Remote keyboard	17
TRD – Thermostat with display	18
Serial connection	19
Serial connection	19
Supervision	19
KSC – Clock card	19
Performance	20
Choice of a chiller or heat pump and use of the performance tables	20
Performance data	21
Pressure drops	29
Residual static pressure	30
Power levels and sound pressure	34
Operating limits	35
Use of anti-freeze solutions	35
RC100 and DS accessories: performances and pressure drops	36
TCAEBY dimensions and footprints	41
Clearances and positioning	42
Handling and storage	42
Installation and connection to the system	42
TCAETY-TCAESY-TCAEQY-THAETY-THAESY dimensions and footprints	43
Clearances and positioning	44
Handling and storage	44
Installation and connection to the system	44
Weight distribution	45
TCAEBY weights	45
TCAETY – TCAESY – TCAEQY weights	45
THAETY – THAESY Weights	46
DS - RC100 accessory weights	46
Water connections	47
Maximum water circuit content	47
Water data	47
Expansion tank technical data	47
Water circuits	48
Electrical connections	50

General Features

Intended Conditions of Use

The TCAEBY, TCAETY, TCAESY and TCAEQY units are packaged air-cooled water chillers with axial fans, available in standard, high temperature/efficiency, silenced and supersilenced versions respectively. The THAETY and THAESY units are packaged reversible air cooled heat pumps on the cooling cycle with axial fans in the high temperature/efficiency and silenced versions respectively.

They are designed for use in air conditioning or industrial process systems that require cooled water (TCAEBY, TCAETY, TCAESY, TCAEQY) or heated and cooled water (THAETY, THAESY), not water for human consumption.

The units comply with the following directives:

- o Machinery directive 98/37/EEC (MD);
- o Low voltage directive 2006/95/EC (LVD);
- o Electromagnetic compatibility Directive 89/336/EEC (EMC);
- o Pressure equipment Directive 97/23/EEC (PED).

The units are designed for outdoor installation.

Guide to reading the code

"SERIES" code

"MODEL" code

T Water production unit	C Cooling only	A Air-cooled	E Scroll-type hermetic compressors	B Standard	Y R410A refrigerant fluid	4 No. compressors	160÷320 Approximate cooling capacity (in kW)
	H Heat pump			T High temperature/efficiency			
				S Silenced			
				Q Supersilenced			

Potential in stallations:

Standard:

Installation without pump and without water buffer tank

Pump:

P1 – Installation with pump.

P2 – Installation with increased static pressure pump.

DP1 – Installation with double pump, including an automatically activated pump in stand-by.

DP2 – Installation with increased static pressure double pump, including an automatically activated pump in stand-by.

Tank & Pump:

ASP1 – Installation with pump and water buffer tank

ASP2 – Installation with increased static pressure pump and water buffer tank

ASDP1 – Installation with double pump, including an automatically activated pump in stand-by and water buffer tank

ASDP2 – Installation with increased static pressure double pump, including an automatically activated pump in stand-by and water buffer tank

Example: TCAEQY 4160 ASP1

- o Water production unit
- o Cooling only;
- o Air cooled;
- o With 4 x hermetic Scroll compressors;
- o Supersilenced unit;
- o With R410A refrigerant fluid;
- o Nominal cooling capacity of approximately 160 kW;
- o Installation with pump and water buffer tank.

New Y-Pack series

Energy-saving, reliable and versatile water chillers and heat pumps

A complete, flexible range, with three shutter steps

New water chillers and heat pumps from 160 to 320 kW in R410A, with four Scroll compressors installed on two cooling circuits to obtain four steps of cooling and heating capacity, allowing for flexible regulation and greater efficiency when operating at partial loads. The efficiency of these units is also boosted by the innovative **AdaptiveFunction Plus** control logic, with which the range is equipped. This logic, developed by *RHOSS* in partnership with the University of Padua, optimises compressor activation and their operating cycles, as well as making it possible to obtain optimum comfort levels in all working conditions and the best performances in terms of energy efficiency during seasonal operation.

LOW ENERGY CONSUMPTION water chillers and heat pumps

The **AdaptiveFunction Plus "Economy"** function combines comfort with low energy consumption. In fact, by adjusting the set-point value, it optimises compressor operation on the basis of the actual working conditions.

It is thus possible to achieve significant seasonal energy savings compared to water chillers and heat pumps of an equivalent power with traditional control logic.

HIGH PRECISION water chillers and heat pumps

By using the **AdaptiveFunction Plus "Precision"** function, it is possible to achieve as little fluctuation as possible, at partial capacities, in terms of the average Set-point water temperature delivered to the users.

Guaranteed reliability, even with water in the pipes only

Thanks to the "**Virtual Tank**" function, Y-Pack units with **AdaptiveFunction Plus** can operate in systems with a low water content of down to 2 litres/kW, even without the presence of a water buffer tank, whilst still guaranteeing the reliability of the units over time and the good working order of the system.

Estimation of the system's thermal inertia

Y-Pack units with **AdaptiveFunction Plus** are able to estimate the characteristics of the thermal inertia that regulates the system dynamics. This is possible thanks to the "**ACM Autotuning**" function, which processes the information relating to the progress of the water temperatures, identifying the optimal value of the control parameters.

Continuous system autodiagnosis

The estimation function is always active and makes it possible to adapt the control parameters quickly to every change in the water circuit and thus in the system water contents.

Silent operation (VERSIONS S and Q)

Thanks to the 4 shutter steps and the condensation control, installed as standard on all S and Q units, the noise level is also reduced at partial loads. For example, during night operation, when the load is reduced but sensitivity to noise is at its peak, the control reduces the number of fan revolutions, the primary noise source in this type of unit, producing obvious benefits in terms of acoustic well-being.

AdaptiveFunction Plus

The new adaptive regulation logic, **AdaptiveFunction Plus**, is an exclusive *RHOSS* patent and the result of a long partnership with the University of Padua. The various algorithm processing and development operations were implemented and tested on units in the Y-PACK range in the *RHOSS Research&Development* Laboratory by means of numerous test campaigns.

Objectives

- To guarantee optimal unit operation in the system in which it is installed. **Evolved adaptive logic.**
- To obtain the best possible performance from a water chiller and a heat pump in terms of energy efficiency at full and partial loads. **Low consumption chiller.**

Operating logic

In general, the actual control logics on water chillers/heat pumps do not consider the characteristics of the system in which the units are installed; they usually regulate the return water temperature and are positioned so as to ensure the operation of the chillers, giving less priority to the system requirements.

The new **AdaptiveFunction Plus** adaptive logic counters these logics with the objective of optimising the chiller operation on the basis of the system characteristics and the effective thermal load. The controller regulates the delivery water temperature and adjusts itself, as and when required, to the relative operating conditions using:

- the information contained in the return and delivery water temperature to estimate the working conditions thanks to a certain mathematical formula;

- a special adaptive algorithm that uses this estimate to vary the values and the start-up and switch-off limit values of the compressors; the optimised compressor start-up management guarantees a precision water supply to the user, reducing the fluctuation around the set-point value.

Main functions

Efficiency or Precision

Thanks to the evolved control, it is possible to run the chiller on two different regulation settings to obtain the best possible performance in terms of energy efficiency and considerable seasonal savings, or high water delivery temperature precision:

1. Low consumption chiller: "Economy" option

It is well known that chillers work at full capacity for just a very small percentage of their operating time, while they work at partial capacity for most of the season. Therefore, the power they need to supply generally differs from the nominal design power, and operation at partial capacity has a noticeable effect on seasonal energy performance and consumption.

This makes it necessary to run the unit so that it is as efficient as possible at partial capacity. The controller therefore ensures that the water delivery temperature is as high as possible (when operating as a chiller) or as low as possible (when operating as a heat pump) whilst compatible with the thermal loads, meaning that it is on a sliding scale, unlike in traditional systems. This prevents energy wastage linked to the maintenance of pointless onerous temperature levels for the chiller, ensuring that the ratio between the power to be supplied and the energy to be used to produce it is always at an optimum level. Finally the right level of comfort is available to everyone!

Summer season: the Y-Pack unit, with four shutter steps, offers substantial seasonal energy savings on consumption of electricity.

Winter season: the Y-Pack unit with 4 shutter steps enables seasonal energy consumption savings. According to our calculations, the seasonal consumption is equivalent to that of a **CLASS A** machine.

Annual: efficiency over the annual operation of the unit in heat pump mode. **AdaptiveFunction Plus**, with the "Economy" function, enables the chiller assembly to operate energy-saving programmes whilst still providing the required level of comfort.

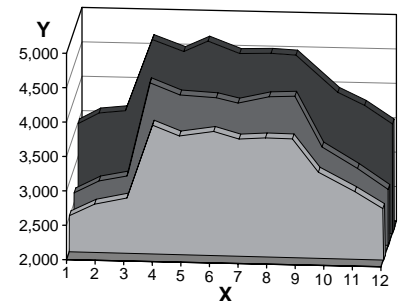
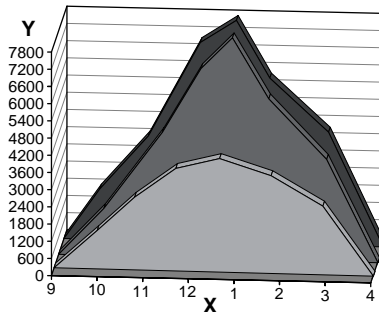
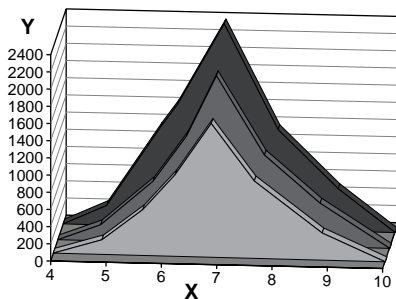

- X** Year divided into months (1 January, 2 February, etc.).
- Y** Energy consumption (kWh).
- Mono-compressor unit with fixed set-point.
- Bi-compressor unit, 2 shutter steps with fixed set-point.
- Bi-compressor or Compact-Y unit, 3 shutter steps with scrolling set-point.

- X** Year divided into months (1 January, 2 February, etc.).
- Y** Energy consumption (kWh).
- Mono-compressor unit with fixed set-point.
- Bi-compressor unit, 2 shutter steps with fixed set-point.
- Bi-compressor or Compact-Y unit, 3 shutter steps with scrolling set-point.

- X** Year divided into months (1 January, 2 February, etc.).
- Y** Energy efficiency kWh supplied / kWh absorbed.
- Bi-compressor or Compact-Y unit, 3 shutter steps with scrolling set-point.
- Bi-compressor unit, 2 shutter steps with fixed set-point.
- Mono-compressor unit with fixed set-point.

Analysis conducted in an office building in Milan, comparing the operation of:

- a mono-compressor reversible heat pump, which operates with a fixed set-point (7°C in the summer and 45°C in the winter);
- a reversible heat pump unit with two compressors, of equal power, operating on the same refrigerant circuit and working with a fixed set-point (7°C in the summer and 45°C in the winter);
- a Compact-Y unit with three shutter steps and **AdaptiveFunction Plus** logic, which operates with a scrolling set-point (range between 7 and 14°C in the summer, range between 35 and 45°C in the winter).

2. High precision: "Precision" option

In this operating mode, the unit works at a fixed set-point and, thanks to the delivery water temperature control and the evolved regulation logic, at a capacity of between 50% and 100% it is possible to guarantee an average fluctuation from the water supply temperature of approximately $\pm 1.5^\circ\text{C}$ from the set-point value compared to an average fluctuation over time of approximately $\pm 3^\circ\text{C}$, which is normally obtained with standard return control. The "Precision" option thus guarantees precision and reliability for all those applications that require a regulator that guarantees a more accurate constant water supply temperature, and where there are particular damp control requirements. However, in process applications it is always advisable to use a water buffer tank or a greater system water content to guarantee higher system thermal inertia.

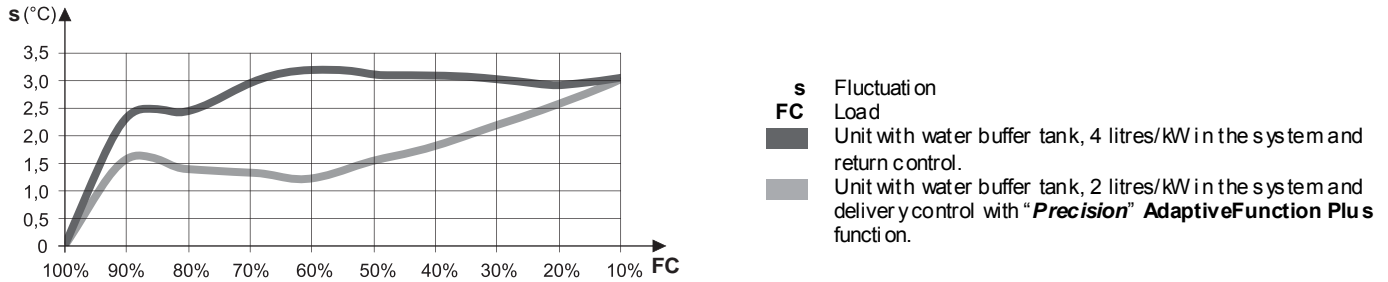

The chart illustrates the fluctuations of the water temperature from the set value for the various capacities, demonstrating how a unit with delivery control and the AdaptiveFunction Plus "Precision" function guarantees greater water supply temperature precision

Virtual Tank: guaranteed reliability, even with water in the pipes only

A low water content in the system can cause the chiller units/heat pumps to be unreliable and can generate system instability and lack of performance. Thanks to the Virtual Tank function, this is no longer a problem. The unit can operate in systems with just 2 litres/kW in the pipes given that the control is able to compensate for the lack of inertia specific to a water buffer tank, "muffling" the control signal, preventing the compressor from switching on and off in an untimely fashion and reducing the average fluctuation of the set-point value.

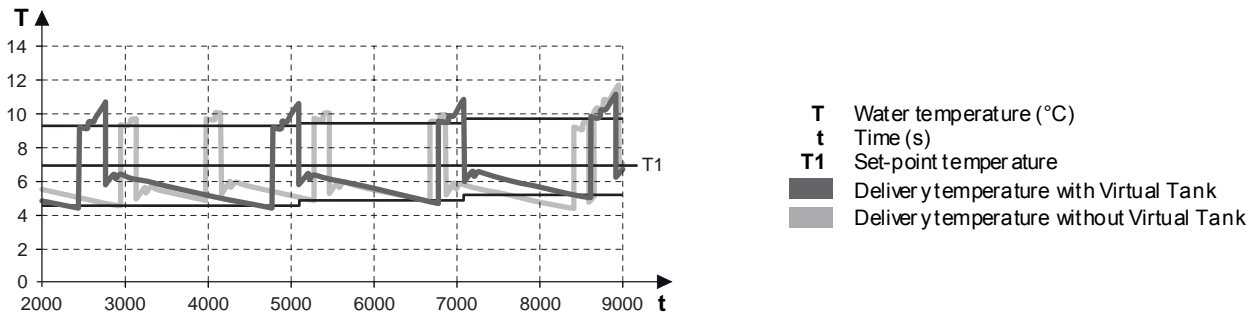

The chart shows the various chiller outlet temperatures considering capacity of 80%. We can observe how the temperatures of the unit with AdaptiveFunction Plus logic and the Virtual Tank function is far less varied and more stable over time, with average temperatures closer to the working set-point compared to a unit without the Virtual Tank function. Moreover, we can see how the unit with AdaptiveFunction Plus logic and the Virtual Tank function switches the compressor on less often over the same period of time, with obvious advantages in terms of energy consumption and system reliability.

ACM Autotuning compressor management

AdaptiveFunction Plus enables the Y-Pack units to adapt to the system they are serving, so as to always identify the best compressor operating parameters in the different working conditions.

During the initial operating phases, the special "Autotuning" function enables the Y-Pack unit with AdaptiveFunction Plus to estimate the thermal inertia characteristics that regulate the system dynamics. The function, which is automatically activated when the unit is switched on for the first time, executes a number of set operating cycles, during which it processes the information relative to the water temperatures. It is thus possible to estimate the physical characteristics of the system and to identify the optimal value of the parameters to be used for the control.

At the end of this initial auto-estimate phase, the "Autotuning" function remains active, making it possible to adapt the control parameters quickly to every change in the water circuit and thus in the system water contents.

TCAEBY TCAETY TCAESY TCAEQY THAETY THAESY Models 4160-4320

Construction features

- Load-bearing structure and panels in galvanised and painted (RAL 9018) sheet steel; base in galvanised sheet steel.
- The structure (with the exception of the TCAEBY version) consists of two sections:
 - sound-proofed technical compartment for housing the compressors, the electrical panel and the main components in the refrigerant circuit.
 - aeraulic compartment for housing the heat exchange coils, the plate heat exchangers and the motor-driven fans.
- Hermetic, Scroll-type rotary compressors, complete with internal thermal protection and crankcase heater activated automatically when the unit stops (as long as the power supply to the unit is preserved).
- Adequately insulated, braze-welded plate water side heat exchange in stainless steel.
- Air side heat exchanger comprised of a coil of copper pipes and aluminium fins.
- Motor-driven axial fans with external rotor, equipped with internal thermal protection and complete with a single row of protection grilles for version B and a double row for versions T, S and Q.
- Proportional electronic device for the pressurised and continuous regulation of the fan rotation speed down to an external air temperature of -10°C when operating as a water chiller and up to an external air temperature of 40°C when operating as a heat pump (as standard in versions S and Q).
- Victaulic type water connections.
- Differential pressure switch that protects the unit from any interruptions to the water flow.
- Double refrigerant circuit in annealed copper pipe (EN 12735-1-2) complete with: cartridge drier filter, charge connections, manual reset safety pressure switch on the high pressure side, automatic reset safety pressure switch on the low pressure side, safety valve(s), filter shut-off valves, thermostatic expansion valve, cycle inversion valve (for THAETY-THAESY), liquid receiver (for THAETY-THAESY) and non-return valves, liquid indicator, gas separator on the compressor inlet and solenoid valve on the liquid line (for THAETY-THAESY) and inlet line insulation.
- Unit with IP24 level of protection.
- Compatible **idRHOSS** control, with **AdaptiveFunction Plus** function.
- The unit is complete with the R410A refrigerant charge.

Versions

- B** – Standard chiller only version (TCAEBY).
- T** – High temperature/high efficiency version, with larger coil surface (TCAETY-THAETY).
- S** – Silenced version complete with soundproofed compressors, lower fan speed and larger coil surface (TCAESY-THAESY). The fan speed is automatically increased with the external temperature increases considerably.
- Q** – Supersilenced version complete with soundproofed compressors, super-reduced fan speed and larger coil surface (TCAEQY). The fan speed is automatically increased with the external temperature increases considerably.

Potential installations

Standard:

Installation without pump and without water buffer tank.

Pump:

P1 – Installation with pump.

P2 – Installation with increased static pressure pump.

DP1 – Installation with double pump, including an automatically activated pump in stand-by.

DP2 – Installation with increased static pressure double pump, including an automatically activated pump in stand-by.

The pump assembly also comes complete with: expansion tank, safety valve, manual air bleed and water side pressure gauge. In the case of an individual pump, the assembly also comes complete with an aspiration and delivery shut-off valve. In the case of a double pump, the assembly also comes complete with a delivery non-return valve and an aspiration valve for each pump.

Tank & Pump:

ASP1 – Installation with pump and water buffer tank.

ASP2 – Installation with increased static pressure pump and water buffer tank.

ASDP1 – Installation with double pump, including an automatically activated pump in stand-by and water buffer tank.

ASDP2 – Installation with increased static pressure double pump, including an automatically activated pump in stand-by and water buffer tank.

In addition to that supplied with the pump accessory, the assembly also includes: 750-l inertial water buffer tank in delivery (excluding models TCAEBY 4160-4180-4200), air bleed valve, water drain valve and electric heater connection.

Electrical board

- Electrical board accessible by opening the front panel, conforming with current IEC norms, can be opened and closed with a suitable tool.
- Complete with:
 - electrical wiring arranged for power supply 400-3ph+N-50Hz;
 - auxiliary power supply 230V-1ph-50Hz drawn from the main power supply;
 - control power supply 12V-1ph-50Hz drawn from the main power supply;
 - general isolator, complete with door interlocking isolator;
 - automatic thermal overload switch to protect the compressors and the motor-driven fans;
 - protection fuse for the auxiliary circuit;
 - power contactor for the compressors;
 - remote machine controls: remote ON/OFF, summer/winter selector;
 - remote machine controls: compressor operating light, general lock light;
 - Programmable electronic board with microprocessor, controlled by the keyboard inserted in the machine.
 - This electronic board performs the following functions:
 - regulation and management of the set points for unit outlet water temperature; cycle inversion (THAETY-THAESY); safety timer delays; circulating pump; compressor and system pump hour-run meter; pressurised defrost cycles; electronic anti-freeze protection which cuts in automatically when the machine is switched off; and the functions which control the operation of the individual parts making up the machine;
 - complete protection of the unit, automatic emergency shutdown and display of the alarms which have been activated;
 - compressor protection phase sequence monitor;
 - unit protection against low or high phase power supply voltage;
 - display of the programmed set-points on the display; of the water in/out temperatures on the display; of the condensation and condensation/evaporation pressures (THAETY-THAESY); of the electrical voltage values in the three phases of the electrical circuit that powers the unit; of the alarms on the display; of the chiller or heat pump function on the display (THAETY-THAESY);
 - user interface menu;
 - automatic pump operating time balance (DP1-DP2, ASDP1- ASDP2 installations);

- automatic activation of the pump in standby in the event of an alarm (DP1-DP2, ASDP1-ASDP2 installations);
- display of the heat recovery/desuperheater inlet water temperature (TRD accessory);
- alarm code and description;
- alarm history management (menu protected by manufacturer password).
 - The following is memorized for each alarm:
 - date and time of intervention (if the KSC accessory is present);
 - inlet/outlet water temperatures when the alarm intervened;
 - the condensation values at the time of the alarm, if the FI10 accessory is present for versions B and T and always for versions S and Q.
- alarm delay time from the switch-on of the connected device;
- compressor status at moment of alarm;
- Advanced functions:
 - Hi-Pressure Prevent with forced cooling capacity shuttering for high external temperatures (during summer operation),
 - configured for serial connection (KR S485, KFTT10, KRS232 and KUSB accessory);
 - possibility to have a digital input for remote management of the double set point (contact *RHOSS* S.p.A. pre-sales).
 - possibility to have an analogue input for the scrolling set-point via a 4-20mA remote signal (contact *RHOSS* S.p.A. pre-sales);
 - configured for management of time bands and operation parameters with the possibility of daily/weekly operating programs (KSC accessory);
 - check-up and monitoring of scheduled maintenance status;
 - testing of the units assisted by computer;
 - self-diagnosis with continuous monitoring of the functioning of the unit.
 - Set-point regulation via the **Adaptive Function Plus** with two options:
 - fixed set-point (**Precision** options);
 - scrolling set-point (**Economy** option).

Accessories

Factory fitted accessories

- P1** – Installation with pump.
P2 – Installation with increased static pressure pump.
DP1 – Installation with double pump, including an automatically activated pump in stand-by.
DP2 – Installation with increased static pressure double pump, including an automatically activated pump in stand-by.
ASP1 – Installation with pump and water buffer tank (excluding TCAEBY models 4160-4180-4200).
ASP2 – Installation with increased static pressure pump and water buffer tank (excluding TCAEBY models 4160-4180-4200).
ASDP1 – Installation with double pump, including one automatic pump in stand-by and water buffer tank (excluding TCAEBY models 4160-4180-4200).
ASDP2 – Installation with increased static pressure double pump, including one automatic pump in stand-by and water buffer tank (excluding TCAEBY models 4160-4180-4200).

FI10 – Modulated condensation control for continuous operation, as chiller down to an external temperature of -10°C (for versions B and T only).

RA – Evaporator antifreeze electric heater to prevent the risk of ice formation inside the exchanger when the machine is switched off (as long as the unit is not disconnected from the power supply)

RDR – Antifreeze electric heater for desuperheater / heat recovery (DS or RC100), to prevent the risk of ice formation inside the recovery exchanger when the machine is switched off (as long as the unit is not disconnected from the power supply).

RAS – 300W antifreeze electric heater for water buffer tank (available for ASP1-ASDP1- ASP2-ASDP2 installations); to prevent the risk of ice formation in the water buffer tank when the machine is switched off (as long as the unit is not disconnected from the power supply).

RAE 1 – 27W antifreeze electric heater for motor-driven pump (available for P1-DP1-ASP1-ASDP1 installations); to prevent the water contained in the pump from freezing when the machine is switched off (as long as the unit is not disconnected from the power supply).

RAE 2 – 27W antifreeze electric heater for double motor-driven pumps (available for P2-DP2-ASP2-ASDP2 installations); to prevent the water contained in the pumps from freezing when the machine is switched off (as long as the unit is not disconnected from the power supply).

DS – Desuperheater (excluding TCAEBY models).

RC100 – Heat recovery with 100% recovery, the accessory comes complete with condensation control FI10 (as standard in versions S and Q) and a differential pressure switch on the recovery exchanger. It is not active as a heat pump during operation.

TRD – Thermostat with display of the inlet water temperature at the heat recovery/desuperheater with possibility to set the activation set-point of an external regulation device if present.

GM – Refrigerant circuit high and low pressure gauges.

FTT10 – FTT10 serial interface card for connection to supervision systems (LonWorks® system compliant with Lonmark® 8090-10 protocol with chiller profile).

SS – RS485 serial interface card to create dialogue networks between cards (maximum of 200 units at a maximum distance of 1,000 m) and building automation, external supervision systems or *RHOSS* S.p.A. supervision systems. (Supported protocols: proprietary protocol; Modbus® RTU).

CR – Power factor correction capacitors ($\cos\Phi > 0.91$).

EEV – Electronic thermostatic valve.

RAP – Unit with copper/pre-painted aluminium coils.

BRR – Unit with copper/copper coils.

RRS – Unit with copper/tin-plated copper coils.
DSP – Double set-point via digital consensus (incompatible with the CS accessory).

CS – Scrolling set point via analogue signal 4-20 mA (incompatible with the DSP accessory). On the basis of the required values, it could be necessary to install the EEV accessory too.

RPB – Coil protection mesh for accident prevention purposes (to be used as an alternative to the FMB accessory) (not available for TCAEBY models).

FMB – Mechanical filters to protect the coils from blockages caused by leaves etc. (to be used as an alternative to the RPB accessory) (not available for TCAEBY models).

BCI – Soundproofed compressor box (TCAEBY only).

SIL – Silent installation (TCAEBY only). The accessory also comprises the BCI and FI10 accessories. With the SIL accessory, cooling performance is reduced by 4%.

Accessories supplied loose

KSAM – Spring anti-vibration mountings.

KSA – Rubber anti-vibration mountings.

KSC – Clock card to display date/time and to regulate the machine with daily/weekly start/stop time bands, with the possibility to change the set-points.

KTR – Remote keypad for control at a distance with rear illuminated LCD display (same functions as the one built into the machine).

KISI – CAN bus serial interface (Controller Area Network compatible with evolved hydronic system **IDRHOSS** for integrated comfort management (protocols supported CANOpen®).

KRS232 – RS485/RS232 serial converter for interconnection between RS485 serial network and supervision systems with serial connection to PC via RS232 serial port (RS232 cable provided).







KUSB – RS485/USB serial converter for interconnection between RS485 serial network and supervision systems with serial connection to PC via USB port (USB cable provided).

KMDM – GSM 900-1800 modem kit to be connected to the unit for the management of the parameters and any alarm signals on a remote basis. The kit consists of a GSM modem with relative RS232 card. It is necessary to purchase a SIM data card, not supplied by *RHOSS* S.p.A.

KRS – *RHOSS* S.p.A. supervision software for unit monitoring and remote management. The kit consists of a CD-Rom and hardware key.

Technical data

Table "A": Technical data

TCAEBY model		4160	4180	4200	4230	4260	4290	4320	
Nominal cooling capacity (*)		kW	152,0	170,0	191,0	219,0	244,0	282,0	315,0
E.E.R. (4th step, 100%)			2,57	2,51	2,51	2,53	2,51	2,52	2,55
E.E.R. (3rd step)			2,78	2,71	2,71	2,73	2,71	2,72	2,76
E.E.R. (2nd step)			3,19	3,12	3,12	3,14	3,12	3,13	3,17
E.E.R. (1st step)			2,71	2,64	2,64	2,66	2,64	2,65	2,68
E.S.E.E.R.			3,80	3,77	3,81	3,82	3,81	3,80	3,85
Sound pressure (***)		dB(A)	66	70	70	72	72	74	74
Sound power level (****)		dB(A)	90	92	92	94	94	95	95
Scroll/step compressor		No.	4/4	4/4	4/4	4/4	4/4	4/4	4/4
Circuits		No.	2	2	2	2	2	2	2
Fans		No. x kW	3 x 2,00	3 x 2,00	3 x 2,00	4 x 2,00	4 x 2,00	5 x 2,00	5 x 2,00
Fan nominal air flow		m³/h	57200	57200	56000	77000	77000	96000	93000
Water side heat exchanger water content		l	9	11	16	18	21	23	26
Water side heat exchanger nominal water flow (*)		m³/h	26,1	29,2	32,8	37,6	41,9	48,4	54,0
Water side heat exchanger nominal pressure drops (*)		kPa	62	58	57	61	58	63	64
Residual static pressure P1 (*)		kPa	122	108	142	122	109	141	106
Residual static pressure P2 (*)		kPa	180	165	219	196	180	221	189
Residual static pressure ASP1 (*)		kPa	-	-	-	116	101	130	93
Residual static pressure ASP2 (*)		kPa	-	-	-	189	172	210	175
Tank water content (ASP1/ASP2)		l	-	-	-	750	750	750	750
R410A refrigerant charge						See serial No. date			
Polyester oil charge						See compressor plate			
Electrical data									
Absorbed power (*) (●)		kW	59,1	67,7	76,1	86,6	97,2	111,9	123,9
Pump absorbed power (P1/ASP1) / (P2/ASP2)		kW	2,2/3,0	2,2/3,0	4,0/5,5	4,0/5,5	4,0/5,5	5,5/7,5	5,5/7,5
Electrical power supply		V-ph-Hz	400 – 3+N – 50						
Auxiliary power supply		V-ph-Hz	230 – 1+N – 50						
Control power supply		V-ph-Hz	24 – 1 – 50						
Nominal current (■)		A	107,0	119,0	129,0	145,0	163,0	183,0	203,0
Maximum current (■)		A	128,0	139,0	150,0	170,0	186,0	217,0	244,0
Start-up current (■)		A	297,0	329,0	340,0	399,0	416,0	471,0	498,0
Pump absorbed power (P1/ASP1) / (P2/ASP2)		A	5,0/6,0	5,0/6,0	8,0/11,0	8,0/11,0	8,0/11,0	11,0/15,0	11,0/15,0
Dimensions									
Height (a)		mm	2135	2135	2135	2135	2135	2135	2135
Width (b)		mm	1190	1190	1190	1190	1190	1190	1190
Length (c)		mm	3130	3130	3130	4090	4090	5050	5050
Heat exchanger inlet/outlet connections (Metric)		Ø	2 ½"	2 ½"	3"	3"	3"	3"	3"

(*) In the following conditions: condenser input air temperature 35°C; chilled water temperature 7°C; temperature differential at evaporator 5°C.

(***) Sound pressure level in dB(A), measured at a distance of 5 m from the unit, with a directionality factor of 2. The noise measurement refers to the units without pump.

Note:

With an external air temperature of under 35°C in the presence of the F110 accessory (as standard in versions S and Q), the machine noise levels fall to below the nominal value indicated in the table.

(****) Sound power level in dB(A) on the basis of measurements made in compliance with the UNI EN-ISO 3744 standard and Eurovent 8/1. The noise measurement refers to the units without pump.

(■) Current value, excluding the current absorbed by the pump.

(●) Power absorbed by the unit without motor-driven pump.

N.B.:

The values for available static pressure of the pumps and the pressure drops of the exchangers can be found on page 29. The calculation of the E.E.R. and C.O.P. does not take the pump absorption into account. If the SIL accessory is present, the cooling capacity is reduced by 4%; the sound power level is reduced by 6 dB(A).

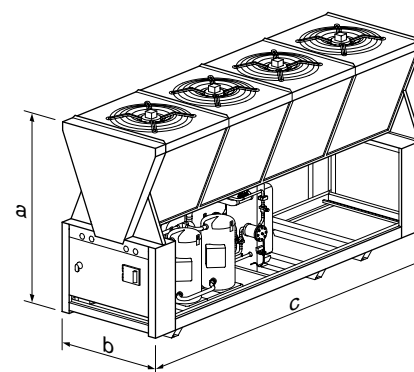









Table "A": Technical data

TCAETY model		4160	4180	4200	4230	4260	4290	4320	
Nominal coding capacity (*)		kW	160,0	182,0	201,0	225,0	257,0	293,0	325,0
E.E.R. (4th step, 100%)			2,87	2,80	2,75	2,75	2,79	2,77	2,70
E.E.R. (3rd step)			3,02	2,95	2,90	2,90	2,94	2,92	2,84
E.E.R. (2nd step)			3,37	3,29	3,23	3,23	3,27	3,25	3,17
E.E.R. (1st step)			3,37	3,29	3,23	3,23	3,28	3,26	3,17
E.S.E.E.R.			4,25	4,20	4,13	4,13	4,19	4,16	4,11
Sound pressure (***)		dB(A)	63	67	67	68	69	69	69
Sound power level (****)		dB(A)	86	91	91	92	93	93	93
Scroll/step compressor		No.	4/4	4/4	4/4	4/4	4/4	4/4	4/4
Circuits		No.	2	2	2	2	2	2	2
Fans		No. x kW	6 x 0,69	4 x 2,00	4 x 2,00	4 x 2,00	6 x 2,00	6 x 2,00	6 x 2,00
Fan nominal air flow		m ³ /h	54300	73600	73600	80800	11400	11000	11000
Water side heat exchanger water content		l	16	16	18	21	23	26	31
Water side exchanger nominal water flow (*)		m ³ /h	27,5	31,2	34,5	38,6	44,1	50,3	55,8
Water side heat exchanger nominal pressure drops (*)		kPa	40	52	52	51	54	56	53
Residual static pressure P1 (*)		kPa	134	98	139	122	96	127	94
Residual static pressure P2 (*)		kPa	192	154	214	196	165	208	177
Residual static pressure ASP1 (*)		kPa	129	92	131	113	83	111	74
Residual static pressure ASP2 (*)		kPa	187	148	207	186	152	192	157
Tank water content (ASP1/ASP2)		l	750	750	750	750	750	750	750
R410A refrigerant charge									See serial No. plate
Polyester oil charge									See compressor plate
Electrical data									
Absorbed power (*) (●)		kW	55,7	65,0	73,1	81,7	92,1	105,8	120,4
Pump absorbed power (P1/ASP1 / (P2/ASP2)		kW	2,2/3,0	2,2/3,0	4,0/5,5	4,0/5,5	4,0/5,5	5,5/7,5	5,5/7,5
Electrical power supply		V-ph-Hz				400 – 3+N – 50			
Auxiliary power supply		V-ph-Hz				230 – 1+N – 50			
Control power supply		V-ph-Hz				24 – 1 – 50			
Nominal current (■)		A	101,0	117,0	128,0	144,0	163,0	181,0	204,0
Maximum current (■)		A	123,0	143,0	154,0	170,0	194,0	221,0	248,0
Start-up current (■)		A	292,0	333,0	344,0	399,0	424,0	475,0	502,0
Pump absorbed power (P1/ASP1) / (P2/ASP2)		A	5,0/6,0	5,0/6,0	8,0/11,0	8,0/11,0	8,0/11,0	11,0/15,0	11,0/15,0
Dimensions									
Height (a)		mm	2000	2030	2030	2030	2030	2030	2030
Width (b)		mm	2090	2090	2090	2090	2090	2090	2090
Length (c)		mm	3700	3700	3700	4800	4800	4800	4800
Exchanger inlet/outlet connections		Ø	2 ½"	2 ½"	3"	3"	3"	3"	3"
DS/RC100 inlet/outlet connections		Ø	2 ½"	2 ½"	3"	3"	3"	3"	3"

(*) In the following conditions: condenser input air temperature 35°C; chilled water temperature 7°C; temperature differential at evaporator 5°C.

(**) Sound pressure level in dB(A), measured at a distance of 5 m from the unit, with a directionality factor of 2. The noise measurement refers to the units without pump.

Note:
With an external air temperature of under 35°C in the presence of the F110 accessory (as standard in versions S and Q), the machine noise levels fall to below the nominal value indicated in the table.

(****) Sound power level in dB(A) on the basis of measurements made in compliance with the UNI EN-ISO 3744 standard and Eurovent 8/1. The noise measurement refers to the units without pump.

(■) Current value, excluding the current absorbed by the pump.

(●) Power absorbed by the unit without motor-driven pump.

N.B.:

The values for available static pressure of the pumps and the pressure drops of the exchangers can be found on page 29. The calculation of the E.E.R. and C.O.P. does not take the pump absorption into account.

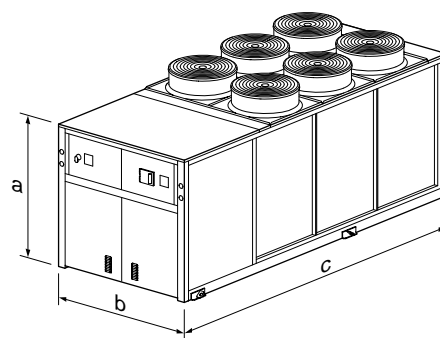









Table "A": Technical data

TCAESY model		4160	4180	4200	4230	4260	4290	4320	
Nominal coding capacity (*)		kW	152,7	177,0	192,0	215,0	246,0	281,0	309,0
E.E.R. (4th step, 100%)			2,74	2,70	2,60	2,60	2,75	2,61	2,55
E.E.R. (3rd step)			2,88	2,84	2,74	2,74	2,90	2,75	2,68
E.E.R. (2nd step)			3,22	3,17	3,05	3,05	3,23	3,06	2,99
E.E.R. (1st step)			3,22	3,17	3,06	3,06	3,23	3,07	3,00
E.S.E.E.R.			4,06	4,05	3,90	3,90	4,13	3,92	3,88
Sound pressure (***)		dB(A)	59	61	61	62	64	64	64
Sound power level (****)		dB(A)	83	86	86	87	89	89	89
Scroll/step compressor		No.	4/4	4/4	4/4	4/4	4/4	4/4	4/4
Circuits		No.	2	2	2	2	2	2	2
Fans		No. x kW	6 x 0.48	4 x 1.25	4 x 1.25	4 x 1.25	6 x 1.25	6 x 1.25	6 x 1.25
Fan nominal air flow		m ³ /h	42000	56800	56800	63600	90000	85400	85400
Water side heat exchanger water content		l	16	16	18	21	23	26	31
Water side heat exchanger nominal water flow (*)		m ³ /h	26,3	30,4	32,9	36,9	42,2	48,2	53,0
Water side heat exchanger nominal pressure drops (*)		kPa	37	49	48	47	51	52	48
Residual static pressure P1 (*)		kPa	144	107	148	133	107	144	118
Residual static pressure P2 (*)		kPa	202	163	224	207	178	223	200
Residual static pressure ASP1 (*)		kPa	139	101	141	124	96	129	99
Residual static pressure ASP2 (*)		kPa	198	157	217	199	166	208	181
Tank water content (ASP1/ASP2)		l	750	750	750	750	750	750	750
R410A refrigerant charge			See serial No. plate						
Polyester oil charge			See compressor plate						
Electrical data									
Absorbed power (*) (●)		kW	55,9	65,6	73,8	82,7	89,5	107,7	121,2
Pump absorbed power (P1/ASP1) / (P2/ASP2)		kW	2,2/3,0	2,2/3,0	4,0/5,5	4,0/5,5	4,0/5,5	5,5/7,5	5,5/7,5
Electrical power supply		V-ph-Hz	400 – 3+N – 50						
Auxiliary power supply		V-ph-Hz	230 – 1+N – 50						
Control power supply		V-ph-Hz	24 – 1 – 50						
Nominal current (■)		A	103,0	114,0	126,0	142,0	157,0	177,0	203,0
Maximum current (■)		A	123,0	143,0	154,0	170,0	194,0	221,0	248,0
Start-up current (■)		A	292,0	333,0	344,0	399,0	424,0	475,0	502,0
Pump absorbed power (P1/ASP1) / (P2/ASP2)		A	5,0/6,0	5,0/6,0	8,0/11,0	8,0/11,0	8,0/11,0	11,0/15,0	11,0/15,0
Dimensions									
Height (a)		mm	2000	2030	2030	2030	2030	2030	2030
Width (b)		mm	2090	2090	2090	2090	2090	2090	2090
Length (c)		mm	3700	3700	3700	4800	4800	4800	4800
Exchanger inlet/outlet connections		Ø	2 ½"	2 ½"	3"	3"	3"	3"	3"
DS/RC100 inlet/outlet connections		Ø	2 ½"	2 ½"	3"	3"	3"	3"	3"

(*) In the following conditions: condenser input air temperature 35°C; chilled water temperature 7°C; temperature differential at evaporator 5°C.

(***) Sound pressure level in dB(A), measured at a distance of 5 m from the unit, with a directionality factor of 2. The noise measurement refers to the units without pump.

Note:

With an external air temperature of under 35°C in the presence of the FI 10 accessory (as standard in versions S and Q), the machine noise levels fall to below the nominal value indicated in the table.

(****) Sound power level in dB(A) on the basis of measurements made in compliance with the UNI EN-ISO 3744 standard and Eurovent 8/1. The noise measurement refers to the units without pump.

(■) Current value, excluding the current absorbed by the pump.

(●) Power absorbed by the unit without motor-driven pump.

N.B.:

The values for available static pressure of the pumps and the pressure drops of the exchangers can be found on page 29. The calculation of the E.E.R. and C.O.P. does not take the pump absorption into account.

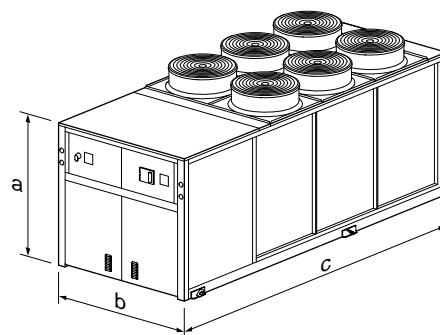









Table "A": Technical data

TCAEQY model		4160	4180	4200	4230	4260	4290	
Nominal cooling capacity (*)		kW	138,0	164,0	181,0	211,0	228,0	259,0
E.E.R. (4th step, 100%)			2,24	2,45	2,25	2,45	2,35	2,25
E.E.R. (3rd step)			2,36	2,58	2,37	2,58	2,47	2,37
E.E.R. (2nd step)			2,63	2,88	2,64	2,88	2,76	2,64
E.E.R. (1st step)			2,63	2,88	2,64	2,88	2,76	2,64
E.S.E.E.R.			3,32	3,68	3,38	3,68	3,53	3,38
Sound pressure (***)		dB(A)	56	58	58	59	60	60
Sound power level (****)		dB(A)	80	83	83	84	85	85
Scroll/step compressor		No.	4/4	4/4	4/4	4/4	4/4	4/4
Circuits		No.	2	2	2	2	2	2
Fans		No. x kW	6 x 0,34	6 x 0,48	6 x 0,48	8 x 0,48	8 x 0,48	8 x 0,48
Fan nominal air flow		m³/h	30600	42000	42000	60800	60800	58000
Water side heat exchanger water content		l	16	16	18	21	23	26
Water side exchanger nominal water flow (*)		m³/h	23,7	28,1	31,1	36,2	39,1	44,4
Water side heat exchanger nominal pressure drops (*)		kPa	32	44	42	46	44	44
Residual static pressure P1 (*)		kPa	162	126	159	136	127	173
Residual static pressure P2 (*)		kPa	222	183	237	211	200	251
Residual static pressure ASP1 (*)		kPa	159	121	153	128	117	160
Residual static pressure ASP2 (*)		kPa	219	178	231	203	190	239
Tank water content (ASP1/ASP2)		l	750	750	750	750	750	750
R410A refrigerant charge								See serial No. date
Polyester oil charge								See compressor plate
Electrical data								
Absorbed power (*) (●)		kW	61,6	66,9	80,4	86,1	97,0	115,1
Pump absorbed power (P1/ASP1) / (P2/ASP2)		kW	2,2/3,0	2,2/3,0	4,0/5,5	4,0/5,5	4,0/5,5	5,5/7,5
Electrical power supply		V-ph-Hz	400 – 3+N – 50					
Auxiliary power supply		V-ph-Hz	230 – 1+N – 50					
Control power supply		V-ph-Hz	24 – 1 – 50					
Nominal current (■)		A	109,0	116,0	130,0	141,0	160,0	185,0
Maximum current (■)		A	123,0	134,0	145,0	164,0	180,0	207,0
Start-up current (■)		A	292,0	325,0	336,0	393,0	410,0	461,0
Pump absorbed power (P1/ASP1) / (P2/ASP2)		A	5,0/6,0	5,0/6,0	8,0/11,0	8,0/11,0	8,0/11,0	11,0/15,0
Dimensions								
Height (a)		mm	2000	2000	2000	2000	2000	2000
Width (b)		mm	2090	2090	2090	2090	2090	2090
Length (c)		mm	3700	3700	3700	4800	4800	4800
Exchanger inlet/outlet connections		Ø	2 ½"	2 ½"	3"	3"	3"	3"
DS/RC100 inlet/outlet connections		Ø	2 ½"	2 ½"	3"	3"	3"	3"

(*) In the following conditions: condenser input air temperature 35°C; chilled water temperature 7°C; temperature differential at evaporator 5°C.

(**) Sound pressure level in dB(A), measured at a distance of 5 m from the unit, with a directionality factor of 2. The noise measurement refers to the units without pump.

Note:

With an external air temperature of under 35°C in the presence of the F10 accessory (as standard in versions S and Q), the machine noise levels fall to below the nominal value indicated in the table.

(****) Sound power level in dB(A) on the basis of measurements made in compliance with the UNI EN-ISO 3744 standard and Eurovent 8/1. The noise measurement refers to the units without pump.

(■) Current value, excluding the current absorbed by the pump.

(●) Power absorbed by the unit without motor-driven pump.

N.B.:

The values for available static pressure of the pumps and the pressure drops of the exchangers can be found on page 29. The calculation of the E.E.R. and C.O.P. does not take the pump absorption into account.

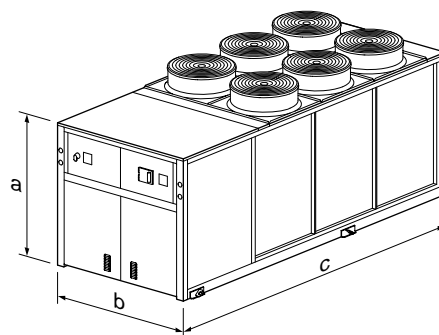















Table "A": Technical data

THAETY model		4160	4180	4200	4230	4260	4290	4320
Nominal cooling capacity (*)	 kW	158,0	179,0	197,0	222,0	253,0	289,0	320,0
E.E.R. (4th step, 100%)		2,81	2,74	2,70	2,70	2,73	2,71	2,65
E.E.R. (3rd step)		2,96	2,89	2,84	2,84	2,88	2,86	2,79
E.E.R. (2nd step)		3,30	3,22	3,16	3,16	3,21	3,19	3,11
E.E.R. (1st step)		3,31	3,22	3,17	3,17	3,21	3,19	3,11
E.S.E.E.R.		4,12	4,07	4,00	4,00	4,06	4,03	3,99
Nominal heating capacity (**)	 kW	166,0	188,0	220,0	241,0	272,0	309,0	342,0
C.O.P.		3,03	2,85	2,98	2,96	2,93	2,92	2,91
Sound pressure (****)	 dB(A)	63	67	67	68	69	69	69
Sound power level (****)	 dB(A)	86	91	91	92	93	93	93
Scroll/step compressor	No.	4/4	4/4	4/4	4/4	4/4	4/4	4/4
Circuits	No.	2	2	2	2	2	2	2
Fans	No. x kW	6 x 0.69	4 x 2.00	4 x 2.00	4 x 2.00	6 x 2.00	6 x 2.00	6 x 2.00
Fan nominal air flow	m³/h	54300	73600	80800	80800	11400	11000	11000
Water side heat exchanger water content	l	16	16	18	21	23	26	31
Water side exchanger nominal water flow (*)	m³/h	27,1	30,7	33,8	38,1	43,4	49,6	54,9
Nom. pressure drops, water side heat exchanger (*)	 kPa	39	50	50	49	52	54	51
Nom. pressure drops, water side heat exchanger (**)		47	59	67	63	65	67	64
Residual static pressure P1 (*)	 kPa	137	103	141	126	101	133	102
Residual static pressure P2 (*)		195	160	217	200	171	214	185
Residual static pressure ASP1 (*)	kPa	132	97	133	117	89	118	82
Residual static pressure ASP2 (*)	kPa	190	154	210	191	159	198	165
Tank water content (ASP1/ASP2)	l	750	750	750	750	750	750	750
R410A refrigerant charge		See serial No. plate						
Polyester oil charge		See compressor plate						
Electrical data								
Absorbed power in summer operation (*) (●)	 kW	56,0	65,3	73,5	82,2	92,6	106,3	121,0
Absorbed power in winter operation (***) (●)		54,8	66,0	73,8	81,4	92,8	105,8	117,5
Pump absorbed power (P1/ASP1 / (P2/ASP2)	kW	2,2/3,0	2,2/3,0	4,0/5,5	4,0/5,5	4,0/5,5	5,5/7,5	5,5/7,5
Electrical power supply	V-ph-Hz	400 – 3+N – 50						
Auxiliary power supply	V-ph-Hz	230 – 1+N – 50						
Control power supply	V-ph-Hz	24 – 1 – 50						
Nominal current in summer operation (*) (■)	A	101,0	117,0	127,0	144,0	163,0	181,0	204,0
Maximum current (■)	A	123,0	143,00	154,0	170,0	194,0	221,0	248,0
Start-up current (■)	A	292,0	333,0	344,0	399,0	424,0	475,0	502,0
Pump absorbed power (P1/ASP1) / (P2/ASP2)	A	5,0/6,0	5,0/6,0	8,0/11,0	8,0/11,0	8,0/11,0	11,0/15,0	11,0/15,0
Dimensions								
Height (a)	mm	2000	2030	2030	2030	2030	2030	2030
Width (b)	mm	2090	2090	2090	2090	2090	2090	2090
Length (c)	mm	3700	3700	4800	4800	4800	4800	4800
Exchanger inlet/outlet connections	Ø	2 ½"	2 ½"	3"	3"	3"	3"	3"
DS/RC100 inlet/outlet connections	Ø	2 ½"	2 ½"	3"	3"	3"	3"	3"

(*) In the following conditions : condenser inlet air temperature 35°C; chilled water temperature 7°C; temperature differential at evaporator 5°C.

(**) In the following conditions : evaporator inlet air temperature 7°C D.B., 6°C W.B.; hot water temperature 45°C; temperature differential at the condenser 5°C.

(***) Sound pressure level in dB(A), measured at a distance of 5 m from the unit, with a directionality factor of 2. The noise measurement refers to the units without pump.

Note:
With an external air temperature of under 35°C in the presence of the F10 accessory (as standard in versions S and Q), the machine noise levels fall to below the nominal value indicated in the table.

(****) Sound power level in dB(A) on the basis of measurements made in compliance with the UNI EN-ISO 3744 standard and Eurovent 8/1. The noise measurement refers to the units without pump.

(■) Current value, excluding the current absorbed by the pump.

(●) Power absorbed by the unit without motor-driven pump.

N.B.:
The values for available static pressure of the pumps and the pressure drops of the exchangers can be found on page 29. The calculation of the E.E.R. and C.O.P. does not take the pump absorption into account.

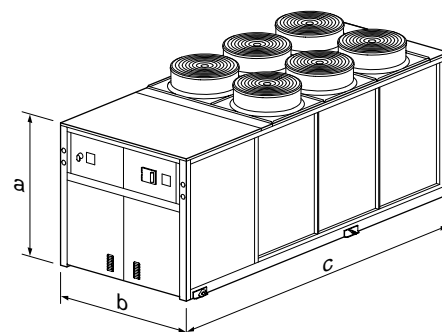











Table "A": Technical data

THAESY model		4160	4180	4200	4230	4260	4290	4320
Nominal cooling capacity (*)	 kW	151,0	174,0	189,0	212,0	242,0	277,0	304,0
E.E.R. (4th step, 100%)		2,69	2,65	2,55	2,55	2,70	2,56	2,50
E.E.R. (3rd step)		2,83	2,79	2,68	2,68	2,84	2,69	2,63
E.E.R. (2nd step)		3,15	3,11	2,99	2,99	3,16	3,00	2,93
E.E.R. (1st step)		3,16	3,11	2,991	2,99	3,17	3,01	2,94
E.S.E.E.R.		3,93	3,93	3,78	3,78	4,00	3,80	3,77
Nominal heating capacity (**)		160,0	183,0	211,0	233,0	264,0	303,0	333,0
C.O.P.		3,00	2,89	3,00	2,98	2,97	3,01	2,96
Sound pressure (***)	dB(A)	59	61	61	62	64	64	64
Sound power level (****)	 dB(A)	83	86	86	87	89	89	89
Scroll/step compressor	No.	4/4	4/4	4/4	4/4	4/4	4/4	4/4
Circuits	No.	2	2	2	2	2	2	2
Fans	No. x kW	6 x 0.48	4 x 1.25	4 x 1.25	4 x 1.25	6 x 1.25	6 x 1.25	6 x 1.25
Fan nominal air flow	m³/h	42000	56800	56800	63600	90000	85400	85400
Water side heat exchanger water content	l	16	16	18	21	23	26	31
Water side exchanger nominal water flow (*)	m³/h	25,9	29,9	32,4	36,4	41,5	47,5	52,2
Nom. pressure drops, water side heat exchanger (*)	 kPa	36	47	47	46	49	51	46
Nom. pressure drops, water side heat exchanger (**)		44	56	62	60	62	64	61
Residual static pressure P1 (*)	 kPa	147	112	148	136	112	149	125
Residual static pressure P2 (*)		205	169	225	211	183	228	207
Residual static pressure ASP1 (**)	kPa	142	106	142	127	101	134	108
Residual static pressure ASP2 (*)	kPa	201	163	219	202	172	214	189
Tank water content (ASP1/ASP2)	l	750	750	750	750	750	750	750
R410A refrigerant charge		See serial No. plate						
Polyester oil charge		See compressor plate						
Electrical data								
Absorbed power in summer operation (*) (●)	 kW	56,1	65,9	74,2	83,1	89,9	108,2	121,8
Absorbed power in winter operation (**) (●)		53,3	63,3	70,3	78,2	88,9	100,7	112,5
Pump absorbed power (P1/ASP1) / (P2/ASP2)	kW	2,2/3,0	2,2/3,0	4,0/5,5	4,0/5,5	4,0/5,5	5,5/7,5	5,5/7,5
Electrical power supply	V-ph-Hz	400 – 3+N – 50						
Auxiliary power supply	V-ph-Hz	230 – 1+N – 50						
Control power supply	V-ph-Hz	24 – 1 – 50						
Nominal current in summer operation (*) (■)	A	103,0	114,0	126,0	142,0	157,0	177,0	203,0
Maximum current (■)	A	123,0	143,0	154,0	170,0	194,0	221,0	248,0
Starting current	A	292,0	333,0	344,0	399,0	424,0	475,0	502,0
Pump absorbed power (P1/ASP1) / (P2/ASP2)	A	5,0/6,0	5,0/6,0	8,0/11,0	8,0/11,0	8,0/11,0	11,0/15,0	11,0/15,0
Dimensions								
Height (a)	mm	2000	2030	2030	2030	2030	2030	2030
Width (b)	mm	2090	2090	2090	2090	2090	2090	2090
Length (c)	mm	3700	3700	4800	4800	4800	4800	4800
Exchanger inlet/outlet connections	Ø	2 ½"	2 ½"	3"	3"	3"	3"	3"
DS/RC100 inlet/outlet connections	Ø	2 ½"	2 ½"	3"	3"	3"	3"	3"

(*) In the following conditions: condenser inlet air temperature 35°C; chilled water temperature 7°C; temperature differential at evaporator 5°C.

(**) In the following conditions: evaporator inlet air temperature 7°C D.B., 6°C W.B.; hot water temperature 45°C; temperature differential at the condenser 5°C.

(***) Sound pressure level in dB(A), measured at a distance of 5 m from the unit, with a directionality factor of 2. The noise measurement refers to the units without pump.

Note:
With an external air temperature of under 35°C in the presence of the FI10 accessory (as standard in versions S and Q), the machine noise levels fall to below the nominal value indicated in the table.

(****) Sound power level in dB(A) on the basis of measurements made in compliance with the UNI EN-ISO 3744 standard and Eurovent 8/1. The noise measurement refers to the units without pump.

(■) Current value, excluding the current absorbed by the pump.

(●) Power absorbed by the unit without motor-driven pump.

N.B.:
The values for available static pressure of the pumps and the pressure drops of the exchangers can be found on page 29. The calculation of the E.E.R. and C.O.P. does not take the pump absorption into account.

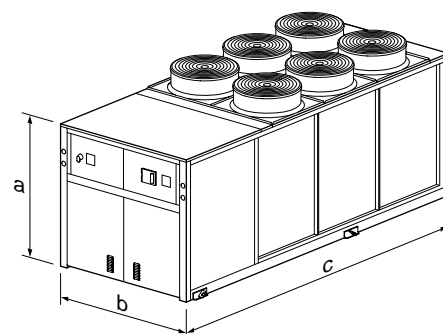

Energy efficiency at partial loads - ESEER index

- The E.E.R. index represents an estimate of the energy efficiency of the cooling unit in nominal design conditions. In reality, the operating time of a chiller in nominal conditions is usually less than the operating time in partial load conditions.
- The I.P.L.V. (Integrated Part Load Value) and E.S.E.E.R. (European Seasonal E.E.R.) indices estimate the average seasonal energy efficiency of the chiller in four load and external air temperature conditions. Generally, two water chillers with the same E.E.R. may have different I.P.L.V. or E.S.E.E.R. values. In fact, for an air-cooled chiller, the average energy efficiency depends on design choices and on the inlet air temperature at the condensing heat exchanger.
- The I.P.L.V. and E.S.E.E.R. energy indices, respectively introduced by the A.R.I. (American Refrigeration Institute – A.R.I. standard 550/590) and the European Community (E.E.C.C.A.C. - Energy Efficiency and Certification of Central Air Conditioners project) have the same formula, but differ in terms of the external air temperatures (see table “B”) and by the energy weights assigned to the four load conditions considered in the calculation: 100%, 75%, 50% and 25%.

$$IPLV = \frac{1 \times EER_{100\%} + 42 \times EER_{75\%} + 45 \times EER_{50\%} + 12 \times EER_{25\%}}{100}$$

$$ESEER = \frac{3 \times EER_{100\%} + 33 \times EER_{75\%} + 41 \times EER_{50\%} + 23 \times EER_{25\%}}{100}$$

where EER_{100%} EER_{75%} EER_{50%} EER_{25%} represent the efficiencies of the cooling unit in the four load conditions and at the temperatures indicated in table “B”.

The data is calculated using Eurovent methodology. The pump absorption (if present) is not taken into consideration.

Table “B”: load and temperature conditions

Load	Condenser inlet air temperature	
	I.P.L.V.	E.S.E.E.R.
100%	35.0°C	35.0°C
75%	26.7°C	30.0°C
50%	18.3°C	25.0°C
25%	12.8°C	20.0°C

○ Table “C” shows the E.E.R., E.S.E.E.R. and I.P.L.V. values for each model.

The high energy efficiency values at partial loads have been obtained thanks to the use of R410A refrigerant, the optimisation of the heat exchangers and the optimal management of the 4 chiller shutter steps.

Table “C”: E.E.R. - E.S.E.E.R. for TC AEBY

Model	E.E.R.	E.S.E.E.R.	I.P.L.V.
4160	2,57	3,80	4,20
4180	2,51	3,77	4,16
4200	2,51	3,81	4,20
4230	2,53	3,82	4,23
4260	2,51	3,81	4,20
4290	2,52	3,80	4,18
4320	2,55	3,85	4,27

Table “C”: E.E.R. - E.S.E.E.R. for TC AETY

Model	E.E.R.	E.S.E.E.R.	I.P.L.V.
4160	2,87	4,25	4,69
4180	2,80	4,20	4,64
4200	2,75	4,13	4,55
4230	2,75	4,13	4,56
4260	2,79	4,19	4,62
4290	2,77	4,16	4,58
4320	2,70	4,11	4,56

Table “C”: E.E.R. - E.S.E.E.R. for TC AESY

Model	E.E.R.	E.S.E.E.R.	I.P.L.V.
4160	2,74	4,06	4,48
4180	2,70	4,05	4,48
4200	2,60	3,90	4,30
4230	2,60	3,90	4,31
4260	2,75	4,13	4,56
4290	2,61	3,92	4,31
4320	2,55	3,88	4,31

Table “C”: E.E.R. - E.S.E.E.R. for TC AEQY

Model	E.E.R.	E.S.E.E.R.	I.P.L.V.
4160	2,24	3,32	3,66
4180	2,45	3,68	4,06
4200	2,25	3,38	3,72
4230	2,45	3,68	4,06
4260	2,35	3,53	3,90
4290	2,25	3,38	3,72

Table “C”: E.E.R. - E.S.E.E.R. for TH AETY

Model	E.E.R.	E.S.E.E.R.	I.P.L.V.
4160	2,81	4,12	4,55
4180	2,74	4,07	4,50
4200	2,70	4,00	4,41
4230	2,70	4,00	4,43
4260	2,73	4,06	4,49
4290	2,71	4,03	4,44
4320	2,65	3,99	4,43

Table “C”: E.E.R. - E.S.E.E.R. for TH AESY





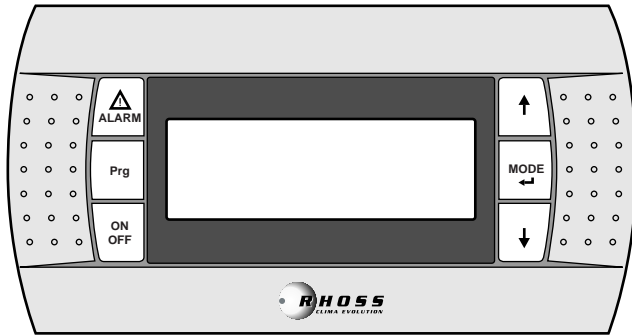

Model	E.E.R.	E.S.E.E.R.	I.P.L.V.
4160	2,69	3,93	4,34
4180	2,65	3,93	4,34
4200	2,55	3,78	4,17
4230	2,55	3,78	4,18
4260	2,70	4,00	4,42
4290	2,56	3,80	4,18
4320	2,50	3,77	4,18

Electronic controls

Electronic control

The keyboard with display makes it possible to view the working temperature and all the unit process variables, as well as providing access to setting parameters for operating set points and their modification. For purposes of technical assistance, it allows password-protected access to the unit's management parameters (access for authorised personnel only).







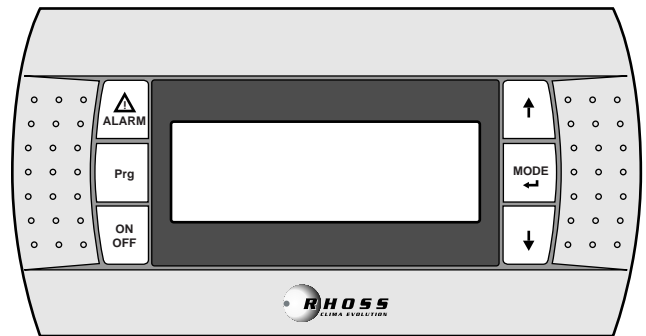

-  **DISPLAY:** displays the numbers and the values of all the parameters (i.e. outlet water temperature etc.), any alarm codes and resource status by means of strings.
-  **ALARM key:** makes it possible to display of the code and reset any alarms.
-  **PRG key:** makes it possible to programme the machine's operating parameters.
-  **ON/OFF key:** makes it possible to switch the unit on and off.
- UP key:** used to scroll through the list of parameters, statuses and any alarms; makes it possible to modify set points. 
- MODE - ENTER key:** makes it possible to switch from chiller to heat pump operation and vice versa. 
- DOWN key:** used to scroll through the list of parameters, statuses and any alarms; makes it possible to modify set points. 

KTR – Remote keyboard

The remote keyboard with display (KTR) allows the remote control and display of all the unit's digital and analogue process variables. It therefore possible to control all the machine functions directly in the room. It allows setting and management of time periods (if KSC accessory is included).



-  **DISPLAY:** displays the numbers and the values of all the parameters (i.e. outlet water temperature etc.), any alarm codes and resource status by means of strings.
-  **ALARM key:** makes it possible to display of the code and reset any alarms.
-  **PRG key:** makes it possible to programme the machine's operating parameters.
-  **ON/OFF key:** makes it possible to switch the unit on and off.
- UP key:** used to scroll through the list of parameters, statuses and any alarms; makes it possible to modify set points. 
- MODE - ENTER key:** makes it possible to switch from chiller to heat pump operation and vice versa. 
- DOWN key:** used to scroll through the list of parameters, statuses and any alarms; makes it possible to modify set points. 

Note:
The temporary presence of two devices, on-board machine keyboard and remote keyboard, will cause the on-board machine terminal to be disabled.

TRD – Thermostat with display

The installation of the thermostat with display (TRD) accessory in the machine makes it possible to display the recovery/desuperheater inlet water temperature and to set the activation set-point of an external regulation device (i.e. ON/OFF 3-way valve) if present, enabling rational and effective use of the recovered thermal energy.

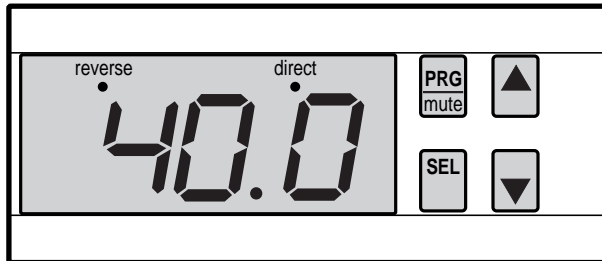

LED reverse If on, it indicates that the heat recovery/desuperheater inlet water temperature is within the activation range, which can be set by the user, of a potential external regulation device.

LED direct Disabled.



DISPLAY: displays the heat recovery/desuperheater inlet water temperature. In the event of a defective sensor, the display value is displayed alternatively.



PRG-mute key: Programming key for exclusive *RHOSS* S.p.A. use.



SEL Key Displays and/or sets the set points.



UP – DOWN keys Makes it possible to modify the set point value.

Serial connection

Serial connection

All units are equipped with electronic control that is set up interface with an external BMS via a serial communication line by means of the KRS485 serial interface accessory (proprietary protocol or ModBus® RTU) and the following converters.

- o **KRS232** – RS485/RS232 converter for connection to supervision systems;
- o **KUSB** – RS485/USB converter for connection to supervision systems.
- o The FTT10 LonWorks® compatible interface is also available.

Supervision

In general, a supervision system allows access to all unit functions, such as:

- o making all settings which are accessible through the keyboard;
- o reading all process variables of the inputs and outputs, whether digital or analogue;
- o reading the various alarm codes which are present, and resetting them as necessary.

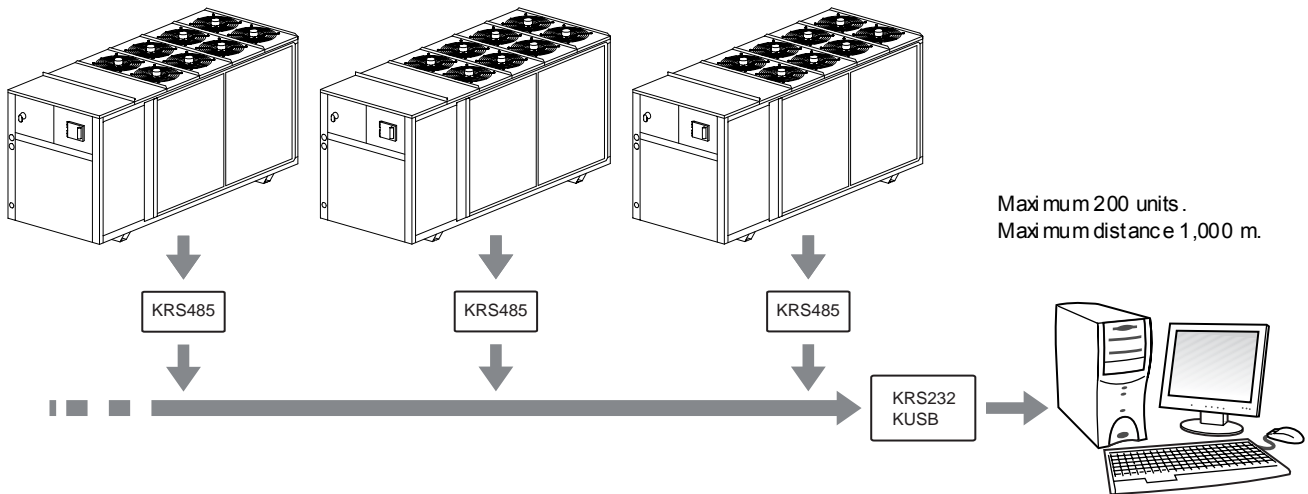

KSC – Clock card

Insertion of the clock card (KSC) favours flexible and efficient use of the unit, showing the date/time and allowing management of the machine in daily or weekly start/stop time periods, with the possibility to change set-points. The time periods can be set and managed from the keyboard.

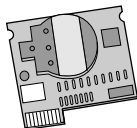

Example of display



Performance

Choice of a chiller or heat pump and use of the performance tables

- For each model, table "D" provides the cooling capacity (**QF**), and the total absorbed electric power (**P**), on the basis of the evaporator outlet water temperature with constant temperature differences $\Delta T = 5^\circ\text{C}$: the value of **QT** is the value of the heating capacity available to the user in winter mode.
- Within the operating limits, the values in table "D" may permit performance interpolations. However, extrapolations are not permitted.
- Table "H" shows the values of the corrective coefficients to be applied to the nominal values if water with glycol is used.
- Graph "1" shows the pressure drop values of the exchangers (with respect to the indicated temperature differentials).
- Graph "2" indicates the useful static pressure of the pump (if present).

Example

- Design conditions for an air-cooled chiller with installation P2:
 - Requested cooling capacity = 190 kW;
 - Temperature of water produced at evaporator = 13°C ;
 - Temperature differential ΔT at the evaporator = 5°C ;
 - Inlet air temperature at condenser = 30°C .

Using the values indicated in table "D", and supposing a temperature differential of $\Delta T = 5^\circ\text{C}$ at the evaporator, it can be seen that model TCAEBY 4160 meets the requirement with:
QF = 190.4 kW; **P** = 60.1 kW;

(*) Comprising the power absorbed by the pump.

The water flow rates **G** to be sent to the exchangers are obtained using the following formulae:

$$\mathbf{G} \text{ (l/h) evaporator} = (\mathbf{QF} \times 0.86) \div \Delta T = (190.4 \times 0.86) \div 5 = 32.75 \text{ (m}^3\text{/h)};$$

Graph "1" shows the pressure drop values Δp_w of the evaporator.

Δp_w evaporator = 94 kPa;

Graph "2" shows the residual static pressure values Δp_r available at the machine outlet 105 kPa.

Calculation of the flow at different Δt :

For machines with **Pump** and **Tank&Pump** installations, it is important to check the performance of the pump if the unit has to operate with Δt other than the nominal one at the exchanger. The calculation of the water flow at an Δt of other than 5°C can be achieved by applying the following formula:

$$\mathbf{G}' = \mathbf{G} \times \Delta t / \Delta t'$$

With **G** and **G'** expressed in m^3/h and Δt and $\Delta t'$ in $^\circ\text{C}$.

For example, in order to establish the flow **G'** of the TCAETY 4260 P1 unit, operating with a temperature differential at the evaporator of $\Delta t' = 4^\circ\text{C}$ and knowing that in nominal conditions, with $\Delta t = 5^\circ\text{C}$, the flow **G** = 41.9 l/h (table A Technical Data), we apply the formula indicated and obtain:

$$\mathbf{G}' = 41.9 \times 5 / 4 = 52.38 \text{ m}^3\text{/h}$$

Using Graph "2" at the identified flow, the useful static pressure is equal to 45 kPa.

Performance data

Table "D": TCAEBY cooling capacity ($\Delta T = 5^\circ\text{C}$ at the evaporator)

Model	Tue (°C)	Ta (°C)									
		25		30		35		40		43	
		QF kW	P kW	QF kW	P kW	QF kW	P kW	QF kW	P kW	QF kW	P kW
4160	5	159,7	49,4	151,5	53,7	143,0	58,2	134,1	63,1	128,4	66,2
	7	169,5	50,3	160,9	54,6	152,0	59,1	142,4	64,0	136,5	67,1
	9	179,3	51,2	170,5	55,4	161,0	60,0	151,2	64,9	145,0	68,0
	11	189,4	52,1	180,5	56,3	170,3	60,8	160,1	65,7	-	-
	13	200,0	53,0	190,7	57,1	180,0	61,7	169,2	66,6	-	-
15	210,9	53,9	200,7	58,0	190,2	62,5	178,8	67,5	-	-	
4180	5	179,7	56,6	170,0	61,4	160,0	66,6	149,5	72,3	143,2	76,0
	7	190,5	57,7	180,7	62,5	170,0	67,7	159,1	73,4	152,2	77,0
	9	201,6	58,8	191,3	63,6	180,2	68,8	168,8	74,5	161,6	78,1
	11	213,4	60,0	202,4	64,8	190,8	70,0	178,9	75,6	-	-
	13	225,1	61,2	213,6	65,9	201,6	71,2	188,9	76,8	-	-
15	237,3	62,3	225,3	67,1	212,5	72,4	199,6	77,9	-	-	
4200	5	201,6	63,0	190,9	68,7	180,4	74,8	168,9	81,7	162,4	86,0
	7	213,0	64,3	202,4	69,9	191,0	76,1	179,5	82,8	172,5	87,1
	9	225,2	65,6	213,9	71,2	202,2	77,3	190,2	84,0	182,9	88,3
	11	237,7	66,8	225,8	72,4	213,9	78,6	201,1	85,3	-	-
	13	250,6	68,1	238,5	73,8	225,5	79,9	212,5	86,6	-	-
15	263,6	69,5	250,8	75,1	237,9	81,3	224,2	88,0	-	-	
4230	5	230,3	72,2	218,8	78,4	206,9	85,3	193,9	92,9	185,8	97,8
	7	243,7	73,4	231,6	79,7	219,0	86,6	205,6	94,1	197,4	98,9
	9	257,9	74,7	244,7	81,0	231,8	87,9	217,8	95,3	209,3	100,1
	11	271,8	76,0	258,7	82,3	244,8	89,2	230,4	96,7	-	-
	13	286,2	77,4	272,4	83,7	258,1	90,5	243,0	98,0	-	-
15	301,4	78,8	286,8	85,1	271,8	92,0	255,9	99,4	-	-	
4260	5	257,5	81,4	244,6	88,2	230,4	95,8	215,7	104,0	206,7	109,1
	7	272,2	82,8	258,6	89,7	244,0	97,2	228,5	105,3	218,9	110,5
	9	287,4	84,3	273,0	91,2	257,6	98,7	241,3	106,7	231,4	111,8
	11	302,7	85,9	287,5	92,8	271,7	100,2	255,0	108,2	-	-
	13	318,5	87,5	302,4	94,4	285,8	101,8	268,2	109,7	-	-
15	334,8	89,1	318,3	96,0	300,4	103,4	282,3	111,2	-	-	
4290	5	296,3	93,7	281,9	101,6	266,5	110,3	249,6	119,9	239,4	126,0
	7	313,5	95,3	298,3	103,2	282,0	111,9	264,7	121,5	254,2	127,6
	9	331,4	96,9	314,8	104,9	298,1	113,6	280,3	123,1	268,7	129,1
	11	349,4	98,7	332,8	106,7	314,7	115,4	296,0	124,8	-	-
	13	368,0	100,5	350,4	108,5	331,9	117,3	312,2	126,7	-	-
15	387,1	102,4	368,7	110,4	349,1	119,2	328,4	128,6	-	-	
4320	5	330,6	103,2	314,3	112,2	297,0	122,1	279,0	133,0	267,8	140,0
	7	349,9	105,0	333,2	113,9	315,0	123,9	295,6	134,7	283,7	141,7
	9	369,8	106,8	351,8	115,8	333,1	125,8	312,8	136,7	300,5	143,5
	11	390,4	108,8	371,4	117,8	351,3	127,8	330,5	138,6	-	-
	13	411,1	110,8	391,6	120,0	370,5	130,0	348,2	140,8	-	-
15	432,4	113,0	412,0	122,2	390,4	132,2	367,0	143,0	-	-	

Ta = Dry bulb external air temperature.

Tue = Evaporator outlet water temperature (ΔT inlet/outlet = 5°C).

QF = Cooling capacity (evaporator fouling factor of $0,35 \times 10^{-4} \text{ m}^2\text{C/W}$).

P = Total absorbed electrical power (compressor and fan).

N.B.:

For the various PUMP and TANK & PUMP versions, add the electrical power values absorbed by the motor-driven pumps and show in tables "A" to the total absorbed electrical power.

Table "D": TCAETY cooling capacity ($\Delta T = 5^\circ\text{C}$ at the evaporator)

Model	Tue (°C)	Ta (°C)											
		25		30		35		40		43		46	
		QF	P	QF	P	QF	P	QF	P	QF	P	QF	P
		kW	kW	kW	kW	kW	kW	kW	kW	kW	kW	kW	kW
4160	5	167,0	45,9	159,2	50,2	151,0	55,0	141,8	60,2	136,1	63,6	130,0	67,1
	7	177,0	46,6	168,7	51,0	160,0	55,7	150,3	61,0	144,5	64,4	138,1	67,9
	9	187,0	47,4	178,5	51,7	169,0	56,5	159,0	61,8	152,8	65,2	146,2	68,8
	11	197,4	48,2	188,3	52,5	178,5	57,3	168,0	62,6	161,6	66,0	-	-
	13	208,0	49,1	198,4	53,3	188,4	58,1	177,2	63,4	-	-	-	-
	15	219,0	49,8	208,8	54,1	198,2	58,9	187,1	64,2	-	-	-	-
4180	5	190,4	54,1	181,1	58,8	171,5	64,1	161,1	70,1	154,7	73,9	148,1	78,0
	7	201,7	54,9	192,2	59,6	182,0	65,0	171,1	71,0	164,4	74,9	157,1	78,9
	9	213,8	55,7	203,4	60,5	192,6	65,9	181,3	71,9	174,2	75,7	166,7	79,8
	11	225,9	56,6	214,9	61,4	203,8	66,8	191,6	72,8	184,0	76,7	-	-
	13	238,3	57,4	227,1	62,2	215,0	67,7	202,6	73,7	-	-	-	-
	15	250,9	58,4	239,0	63,2	226,6	68,6	213,5	74,6	-	-	-	-
4200	5	211,9	60,5	200,7	65,9	189,4	72,1	177,6	78,9	170,1	83,4	162,6	88,1
	7	224,8	61,6	212,9	66,9	201,0	73,1	188,6	80,0	180,9	84,4	173,2	89,1
	9	237,7	62,6	225,6	68,1	213,0	74,2	200,3	81,1	192,1	85,5	183,8	90,2
	11	251,1	63,7	238,6	69,2	225,4	75,5	211,6	82,3	203,2	86,7	-	-
	13	264,5	64,9	251,4	70,5	237,8	76,7	223,7	83,5	-	-	-	-
	15	278,7	66,1	264,9	71,7	250,6	77,9	235,8	84,8	-	-	-	-
4230	5	237,0	68,2	225,0	74,1	212,4	80,6	199,4	87,7	190,8	92,3	182,6	97,0
	7	251,0	69,4	238,3	75,3	225,0	81,7	211,6	88,8	202,8	93,3	194,4	98,0
	9	265,1	70,7	252,0	76,6	238,4	83,0	223,8	90,0	214,8	94,5	205,8	99,1
	11	279,7	72,0	266,2	77,8	251,8	84,2	236,9	91,2	227,3	95,6	-	-
	13	294,7	73,3	280,5	79,1	265,7	85,5	250,0	92,5	-	-	-	-
	15	310,2	74,6	295,2	80,5	279,6	86,9	263,4	93,8	-	-	-	-
4260	5	269,9	77,7	256,1	84,0	242,1	91,0	227,6	98,5	218,1	103,3	208,5	108,4
	7	285,5	78,9	271,3	85,2	257,0	92,1	241,2	99,6	231,9	104,4	221,6	109,4
	9	301,6	80,2	287,1	86,4	271,9	93,3	255,7	100,7	245,3	105,5	235,1	110,4
	11	318,3	81,6	302,9	87,8	287,4	94,6	270,3	101,9	259,5	106,6	-	-
	13	335,6	82,9	319,7	89,1	302,8	95,9	284,8	103,2	-	-	-	-
	15	353,4	84,2	336,1	90,4	318,8	97,2	300,3	104,5	-	-	-	-
4290	5	307,9	88,5	292,2	96,1	276,4	104,5	259,9	113,5	249,9	119,2	238,8	125,3
	7	326,2	89,9	309,7	97,5	293,0	105,8	276,1	114,8	264,9	120,5	253,5	126,5
	9	345,1	91,4	327,7	99,0	310,1	107,2	291,8	116,2	280,3	121,9	268,7	127,9
	11	364,2	92,9	346,3	100,5	328,3	108,6	308,6	117,6	296,8	123,3	-	-
	13	383,8	94,6	365,5	102,0	346,0	110,3	325,8	119,1	-	-	-	-
	15	404,0	96,3	384,8	103,8	364,3	111,9	343,1	120,8	-	-	-	-
4320	5	341,2	100,6	324,3	109,3	306,1	118,6	287,6	128,9	275,8	135,5	263,3	142,3
	7	361,1	102,4	343,1	111,0	325,0	120,4	305,0	130,6	292,3	137,1	279,5	144,0
	9	381,6	104,3	363,2	112,8	343,4	122,2	322,9	132,4	309,9	139,0	296,2	145,7
	11	403,3	106,2	383,9	114,7	363,1	124,1	340,8	134,3	327,5	140,8	-	-
	13	424,7	108,2	404,1	116,7	382,7	126,2	359,9	136,4	-	-	-	-
	15	447,3	110,3	426,2	118,9	403,1	128,3	379,0	138,5	-	-	-	-

Ta = Dry bulb external air temperature.

Tue = Evaporator outlet water temperature (ΔT inlet/outlet = 5°C).

QF = Cooling capacity (evaporator fouling factor of $0.35 \times 10^{-4} \text{ m}^2\text{C/W}$).

P = Total absorbed electrical power (compressor and fan).

N.B.:

For the various PUMP and TANK & PUMP versions, add the electrical power values absorbed by the motor-driven pumps and show in tables "A" to the total absorbed electrical power.

Table "D": TCAESY cooling capacity ($\Delta T = 5^\circ\text{C}$ at the evaporator)

Model	T _{ue} (°C)	T _a (°C)											
		25		30		35		40		43		46	
		QF	P	QF	P	QF	P	QF	P	QF	P	QF	P
		kW	kW	kW	kW	kW	kW	kW	kW	kW	kW	kW	kW
4160	5	160,7	45,8	153,0	50,1	144,6	54,9	135,5	60,2	129,6	63,5	123,9	66,9
	7	169,8	46,7	161,6	51,0	152,7	55,9	143,4	61,1	137,4	64,4	131,3	67,9
	9	179,2	47,5	170,8	51,9	161,4	56,8	151,5	62,0	145,4	65,4	138,9	68,9
	11	189,0	48,4	180,0	52,8	170,3	57,7	159,9	62,9	153,3	66,4	-	-
	13	199,0	49,3	189,5	53,7	179,3	58,6	168,6	63,9	-	-	-	-
	15	209,0	50,2	199,3	54,6	188,4	59,5	177,5	64,8	-	-	-	-
4180	5	185,9	53,9	176,9	59,0	166,9	64,6	156,6	70,9	150,1	74,9	143,4	79,1
	7	197,1	54,9	187,2	59,9	177,0	65,6	166,1	71,9	159,1	75,9	152,4	80,1
	9	208,3	55,9	197,9	61,0	187,4	66,7	175,9	72,9	168,7	76,9	161,6	81,1
	11	219,9	56,9	209,2	62,0	197,8	67,7	186,0	74,0	178,7	78,0	-	-
	13	231,5	58,0	220,3	63,1	208,6	68,8	196,1	75,1	-	-	-	-
	15	243,5	59,1	232,0	64,2	219,6	70,0	206,5	76,2	-	-	-	-
4200	5	203,3	60,4	192,5	66,1	181,1	72,5	169,4	79,7	162,4	84,2	154,9	89,0
	7	215,1	61,6	203,8	67,4	192,0	73,8	179,8	80,9	172,2	85,5	164,7	90,2
	9	227,3	62,9	215,4	68,7	203,3	75,1	190,4	82,2	182,7	86,7	174,8	91,4
	11	239,6	64,2	227,3	70,1	214,6	76,5	201,0	83,6	193,1	88,1	-	-
	13	252,6	65,6	239,7	71,5	226,3	77,9	212,4	85,0	-	-	-	-
	15	265,6	67,0	252,0	72,9	238,3	79,4	223,7	86,5	-	-	-	-
4230	5	227,4	68,5	215,5	74,7	203,2	81,3	190,3	88,6	182,2	93,3	174,1	98,1
	7	240,3	69,9	228,1	76,0	215,0	82,7	201,4	90,0	193,1	94,5	184,8	99,3
	9	253,5	71,3	240,6	77,4	227,2	84,1	213,2	91,3	204,8	95,8	195,8	100,5
	11	267,6	72,7	254,0	78,8	239,8	85,5	225,5	92,7	216,0	97,2	-	-
	13	281,4	74,2	267,4	80,3	252,8	87,0	237,3	94,1	-	-	-	-
	15	296,0	75,7	281,2	81,8	265,8	88,5	249,9	95,6	-	-	-	-
4260	5	259,3	74,9	246,1	81,3	232,4	88,2	217,7	95,8	208,8	100,6	199,3	105,6
	7	274,4	76,2	260,5	82,6	246,0	89,5	230,9	97,0	221,3	101,7	211,6	106,7
	9	289,2	77,6	275,3	83,9	260,0	90,8	244,5	98,3	234,2	103,0	224,3	107,9
	11	305,4	79,0	290,2	85,3	274,5	92,2	258,1	99,6	247,6	104,3	-	-
	13	321,2	80,5	305,6	86,7	289,5	93,6	271,7	101,0	-	-	-	-
	15	337,9	82,0	321,5	88,3	304,4	95,0	286,2	102,4	-	-	-	-
4290	5	295,9	89,4	280,9	97,5	265,3	106,1	248,6	115,5	238,2	121,5	227,7	127,8
	7	313,3	91,1	297,5	99,1	281,0	107,7	263,4	117,0	252,7	123,0	241,5	129,2
	9	330,7	92,9	314,0	100,7	296,7	109,4	278,6	118,7	267,3	124,6	255,8	130,7
	11	348,7	94,6	331,1	102,5	313,4	111,1	294,4	120,4	282,8	126,3	-	-
	13	366,8	96,5	349,3	104,3	330,0	112,9	310,1	122,2	-	-	-	-
	15	385,9	98,4	366,9	106,3	347,2	114,8	326,3	124,1	-	-	-	-
4320	5	326,4	100,7	309,7	109,6	291,8	119,2	273,5	129,6	261,8	136,3	250,0	143,2
	7	345,1	102,7	327,4	111,5	309,0	121,2	289,7	131,7	277,2	138,3	265,1	145,1
	9	364,4	104,7	346,3	113,6	326,3	123,3	305,9	133,6	293,1	140,3	280,1	147,0
	11	384,4	106,8	365,2	115,8	344,7	125,4	322,7	135,9	309,5	142,3	-	-
	13	404,5	109,1	384,2	118,1	362,5	127,7	340,5	138,1	-	-	-	-
	15	425,7	111,5	403,8	120,4	381,5	130,1	357,7	140,5	-	-	-	-

T_a = Dry bulb external air temperature.

T_{ue} = Evaporator outlet water temperature (ΔT inlet/outlet = 5 °C).

QF = Cooling capacity (evaporator fouling factor of $0,35 \times 10^{-4} \text{ m}^2\text{C/W}$).

P = Total absorbed electrical power (compressor and fan).

N.B.:

For the various PUMP and TANK & PUMP versions, add the electrical power values absorbed by the motor-driven pumps and show in tables "A" to the total absorbed electrical power.

Table "D": TCAEQY cooling capacity($\Delta T = 5^\circ\text{C}$ at the evaporator)

Model	Tue ($^\circ\text{C}$)	Ta ($^\circ\text{C}$)									
		25		30		35		40		43	
		QF	P	QF	P	QF	P	QF	P	QF	P
		kW	kW	kW	kW	kW	kW	kW	kW	kW	kW
4160	5	146,4	50,5	138,8	55,3	130,8	60,4	122,0	66,0	116,6	69,5
	7	154,7	51,6	146,5	56,4	138,0	61,6	128,8	67,2	123,2	70,7
	9	162,8	52,7	154,5	57,5	145,5	62,8	136,0	68,4	130,1	71,9
	11	171,3	53,8	162,4	58,7	152,9	63,9	143,2	69,6	-	-
	13	180,0	55,0	170,6	59,8	160,8	65,1	150,7	70,8	-	-
	15	188,6	56,1	179,0	61,0	168,9	66,2	158,4	71,9	-	-
4180	5	174,0	54,6	164,7	59,9	155,0	65,7	145,0	72,1	139,0	76,1
	7	183,7	55,8	174,2	61,1	164,0	66,9	153,7	73,3	146,9	77,4
	9	193,8	57,0	184,0	62,3	173,6	68,2	162,3	74,6	155,7	78,6
	11	204,2	58,2	193,8	63,5	182,8	69,4	171,6	75,8	-	-
	13	214,9	59,4	204,0	64,8	192,6	70,7	180,5	77,1	-	-
	15	225,6	60,7	214,4	66,1	202,4	72,0	190,0	78,4	-	-
4200	5	192,8	65,4	182,2	71,8	171,1	78,9	159,5	86,6	152,5	91,5
	7	203,9	67,0	192,7	73,4	181,0	80,4	169,1	88,1	161,9	93,0
	9	215,1	68,5	203,2	75,0	191,2	82,1	178,8	89,7	171,4	94,4
	11	226,3	70,2	214,1	76,7	201,5	83,8	188,7	91,4	-	-
	13	238,2	71,9	225,3	78,4	212,4	85,5	198,9	93,0	-	-
	15	250,0	73,7	236,5	80,2	222,8	87,3	209,4	94,6	-	-
4230	5	223,3	71,1	211,2	77,6	199,4	84,7	186,6	92,3	178,7	97,2
	7	236,0	72,6	223,9	79,0	211,0	86,1	197,5	93,8	189,4	98,6
	9	249,0	74,1	236,3	80,5	223,0	87,6	209,2	95,2	200,4	99,9
	11	262,5	75,6	249,0	82,1	235,0	89,1	220,9	96,7	-	-
	13	276,4	77,2	262,2	83,7	247,8	90,7	232,5	98,2	-	-
	15	290,4	78,8	275,7	85,3	260,6	92,3	244,4	99,8	-	-
4260	5	241,8	80,7	229,0	87,7	215,5	95,4	201,0	103,6	192,2	108,8
	7	255,5	82,3	242,2	89,4	228,0	97,0	212,7	105,2	203,7	110,3
	9	269,1	84,1	255,1	91,1	240,5	98,7	224,8	106,8	215,1	111,8
	11	283,7	85,8	268,4	92,9	252,9	100,4	236,8	108,4	-	-
	13	297,8	87,7	282,0	94,7	265,7	102,1	249,2	110,1	-	-
	15	312,7	89,5	296,1	96,5	279,4	104,0	261,5	111,8	-	-
4290	5	275,1	95,3	260,4	103,8	245,0	113,1	228,9	123,0	219,1	129,3
	7	290,8	97,3	275,2	105,9	259,0	115,1	242,0	125,0	231,5	131,2
	9	306,0	99,5	290,1	108,0	273,0	117,2	255,1	127,0	244,4	133,1
	11	322,2	101,7	305,4	110,2	287,4	119,4	269,1	129,1	-	-
	13	338,4	104,0	320,7	112,5	302,2	121,7	283,0	131,3	-	-
	15	355,1	106,4	336,4	114,9	317,0	124,0	296,8	133,6	-	-

Ta = Dry bulb external air temperature.

Tue = Evaporator outlet water temperature(ΔT inlet/outlet = 5°C).

QF = Cooling capacity (evaporator fouling factor of $0.35 \times 10^{-4} \text{ m}^2\text{C/W}$).

P = Total absorbed electrical power (compressor and fan).

N.B.:

For the various PUMP and TANK & PUMP versions, add the electrical power values absorbed by the motor-driven pumps and show in tables "A" to the total absorbed electrical power.

Table "D": THAETY cooling capacity ($\Delta T = 5^\circ\text{C}$ at the evaporator)

Model	Tue (°C)	Ta (°C)											
		25		30		35		40		43		46	
		QF	P	QF	P	QF	P	QF	P	QF	P	QF	P
		kW	kW	kW	kW	kW	kW	kW	kW	kW	kW	kW	kW
4160	5	164,9	46,1	157,2	50,5	149,1	55,2	140,0	60,5	134,4	63,9	128,3	67,4
	7	174,8	46,9	166,6	51,2	158,0	56,0	148,4	61,3	142,7	64,7	136,4	68,3
	9	184,7	47,7	176,3	52,0	166,8	56,8	157,0	62,1	150,9	65,5	144,4	69,1
	11	194,9	48,5	186,0	52,8	176,3	57,6	165,9	62,9	159,6	66,3	-	-
	13	205,4	49,3	195,9	53,6	186,0	58,4	175,0	63,7	-	-	-	-
	15	216,3	50,1	206,2	54,4	195,7	59,2	184,8	64,5	-	-	-	-
4180	5	187,3	54,3	178,2	59,1	168,7	64,4	158,5	70,4	152,1	74,3	145,7	78,4
	7	198,4	55,2	189,1	59,9	179,0	65,3	168,2	71,3	161,7	75,2	154,5	79,3
	9	210,2	56,0	200,0	60,8	189,4	66,2	178,3	72,2	171,4	76,1	164,0	80,2
	11	222,1	56,8	211,3	61,7	200,4	67,1	188,5	73,1	181,0	77,1	-	-
	13	234,4	57,7	223,3	62,5	211,5	68,0	199,2	74,0	-	-	-	-
	15	246,7	58,6	235,0	63,5	222,9	68,9	210,0	74,9	-	-	-	-
4200	5	207,6	60,9	196,7	66,4	185,3	72,5	174,5	79,2	167,5	83,5	160,5	88,1
	7	219,9	61,9	208,6	67,4	197,0	73,5	185,2	80,2	178,1	84,5	170,9	89,0
	9	232,8	63,0	221,0	68,5	209,1	74,5	196,7	81,2	189,4	85,5	181,7	90,0
	11	245,9	64,1	233,8	69,6	221,2	75,5	208,5	82,2	200,7	86,5	-	-
	13	259,4	65,2	247,0	70,7	234,1	76,7	220,3	83,3	-	-	-	-
	15	273,0	66,4	260,2	71,8	247,0	77,9	232,9	84,5	-	-	-	-
4230	5	234,2	68,5	222,0	74,5	209,2	81,0	196,3	88,3	188,3	92,9	179,7	97,7
	7	247,7	69,7	235,1	75,7	222,0	82,2	208,4	89,4	199,7	94,0	191,0	98,8
	9	262,0	70,9	248,7	76,9	234,8	83,5	220,9	90,6	211,6	95,1	202,6	99,9
	11	276,3	72,2	262,7	78,2	248,1	84,7	233,3	91,8	224,2	96,4	-	-
	13	291,2	73,5	277,1	79,5	261,8	86,0	246,2	93,1	-	-	-	-
	15	306,5	74,9	291,2	80,8	275,9	87,3	259,5	94,4	-	-	-	-
4260	5	265,7	77,9	252,5	84,4	238,8	91,5	224,1	99,1	214,7	104,1	205,3	109,2
	7	281,5	79,1	267,5	85,6	253,0	92,6	237,5	100,3	227,9	105,1	217,7	110,2
	9	297,8	80,4	283,0	86,8	267,7	93,8	251,3	101,4	241,4	106,2	231,0	111,3
	11	314,3	81,7	299,1	88,1	282,9	95,0	266,0	102,6	255,5	107,4	-	-
	13	331,3	83,0	315,2	89,4	298,1	96,4	280,4	103,8	-	-	-	-
	15	348,8	84,4	331,8	90,7	314,3	97,7	295,6	105,2	-	-	-	-
4290	5	303,7	88,8	288,2	96,6	272,6	105,0	256,4	114,1	245,5	120,0	235,0	126,1
	7	322,2	90,1	305,5	97,9	289,0	106,3	271,9	115,4	260,8	121,2	249,6	127,3
	9	340,4	91,6	323,2	99,3	305,9	107,7	287,9	116,8	276,5	122,6	264,6	128,7
	11	359,2	93,2	341,6	100,8	323,8	109,2	303,9	118,2	292,3	124,0	-	-
	13	378,5	94,8	360,5	102,4	341,3	110,7	320,9	119,8	-	-	-	-
	15	398,5	96,5	379,5	104,1	359,3	112,4	338,4	121,4	-	-	-	-
4320	5	337,0	100,9	319,8	109,8	301,9	119,2	283,2	129,7	271,5	136,3	259,7	143,3
	7	357,1	102,7	338,9	111,4	320,0	121,0	300,2	131,3	287,7	138,0	275,6	145,0
	9	377,4	104,5	358,2	113,2	338,7	122,8	317,9	133,2	305,1	139,7	291,5	146,6
	11	398,3	106,5	378,6	115,1	358,1	124,7	336,1	135,1	322,4	141,7	-	-
	13	420,0	108,4	399,1	117,2	377,5	126,7	354,4	137,1	-	-	-	-
	15	442,3	110,5	420,3	119,3	397,5	128,9	373,2	139,2	-	-	-	-

Ta = Dry bulb external air temperature.

Tue = Evaporator outlet water temperature (ΔT inlet/outlet = 5°C).

QF = Cooling capacity (evaporator fouling factor of $0,35 \times 10^{-4} \text{ m}^2\text{C/W}$).

P = Total absorbed electrical power (compressor and fan).

N.B.:

For the various PUMP and TANK & PUMP versions, add the electrical power values absorbed by the motor-driven pumps and show in tables "A" to the total absorbed electrical power.

Table "D": THAETY heating capacity($\Delta T = 5^\circ C$ at the condenser)

Model	Ta (°C)	RH (%)	Tuc (°C)											
			30		35		40		45		50		53	
			QT	P	QT	P	QT	P	QT	P	QT	P	QT	P
		kW	kW	kW	kW	kW	kW	kW	kW	kW	kW	kW	kW	
4160	-5	90	128,3	39,4	127,0	43,4	125,8	47,9	-	-	-	-	-	-
	0	90	146,4	40,0	144,4	44,0	142,8	48,6	140,6	53,7	-	-	-	-
	7	90	174,9	41,0	172,0	45,0	169,2	49,6	166,0	54,8	162,7	60,6	160,7	64,3
	10	85	187,2	41,5	184,1	45,5	180,5	50,0	176,9	55,2	173,1	61,0	171,0	64,8
	15	85	212,2	42,5	208,3	46,3	203,8	50,8	199,2	55,9	194,2	61,7	191,2	65,6
	20	85	240,5	43,7	235,1	47,2	229,3	51,5	223,8	56,5	217,8	62,3	-	-
4180	-5	90	145,7	48,4	143,8	52,8	142,0	57,9	-	-	-	-	-	-
	0	90	166,9	49,2	164,0	53,6	161,4	58,8	159,0	64,7	-	-	-	-
	7	90	200,1	50,5	195,7	54,8	191,7	60,0	188,0	66,0	184,3	72,8	182,1	77,2
	10	85	214,0	51,0	209,6	55,4	204,7	60,5	200,6	66,5	195,9	73,3	193,3	77,7
	15	85	242,7	52,1	236,9	56,4	231,5	61,5	225,6	67,5	220,0	74,2	216,5	78,6
	20	85	274,4	53,2	267,6	57,5	260,3	62,5	253,8	68,4	246,8	75,1	-	-
4200	-5	90	170,1	53,9	167,6	58,6	165,6	64,4	-	-	-	-	-	-
	0	90	195,6	54,9	191,6	59,6	187,9	65,4	185,4	72,4	-	-	-	-
	7	90	234,7	56,3	229,4	61,1	224,5	67,0	220,0	73,8	215,9	81,6	213,3	86,8
	10	85	251,9	56,9	246,0	61,8	240,6	67,6	235,1	74,4	230,5	82,2	227,8	87,4
	15	85	285,9	58,1	278,9	63,0	272,3	68,8	265,7	75,6	259,5	83,4	255,2	88,5
	20	85	323,9	59,3	315,7	64,2	306,9	70,1	299,0	76,9	290,6	84,7	-	-
4230	-5	90	187,1	59,5	184,8	64,9	182,7	71,4	-	-	-	-	-	-
	0	90	213,5	60,5	210,5	65,9	207,3	72,4	204,1	80,0	-	-	-	-
	7	90	255,3	62,0	250,6	67,4	245,8	73,9	241,0	81,4	236,6	89,9	233,7	95,5
	10	85	273,4	62,6	268,2	68,1	262,8	74,6	257,4	82,1	251,9	90,5	248,5	96,1
	15	85	310,3	63,9	303,3	69,4	296,2	75,9	289,5	83,3	282,3	91,7	278,2	97,2
	20	85	351,2	65,2	342,9	70,8	333,8	77,3	325,3	84,7	316,1	93,1	-	-
4260	-5	90	211,9	69,0	209,6	75,0	207,2	82,3	-	-	-	-	-	-
	0	90	242,1	70,0	238,1	76,0	234,4	83,2	230,7	91,3	-	-	-	-
	7	90	288,7	71,6	283,6	77,7	277,7	84,7	272,0	92,8	266,1	101,9	262,6	107,8
	10	85	309,5	72,3	303,2	78,4	296,6	85,4	290,0	93,4	283,8	102,4	279,6	108,3
	15	85	350,6	73,7	342,9	79,7	335,0	86,8	326,3	94,8	317,5	103,7	312,0	109,6
	20	85	396,8	75,2	387,1	81,3	376,4	88,3	366,2	96,3	355,2	105,2	-	-
4290	-5	90	239,4	78,1	236,9	85,3	234,2	93,7	-	-	-	-	-	-
	0	90	273,9	79,3	269,5	86,3	265,3	94,7	261,0	104,2	-	-	-	-
	7	90	328,6	81,2	322,2	88,2	315,6	96,4	309,0	105,8	301,9	116,4	297,7	123,3
	10	85	353,2	82,0	344,7	89,0	337,5	97,2	330,1	106,6	322,0	117,2	317,0	124,1
	15	85	400,6	83,6	391,3	90,7	381,8	98,9	371,5	108,3	361,1	118,8	354,6	125,7
	20	85	454,4	85,5	442,7	92,6	430,8	100,9	418,1	110,3	405,3	120,8	-	-
4320	-5	90	263,9	86,4	261,3	94,7	259,2	104,3	-	-	-	-	-	-
	0	90	303,0	87,5	298,1	95,6	293,5	105,1	289,9	115,9	-	-	-	-
	7	90	362,6	89,5	355,3	97,5	348,7	106,8	342,0	117,5	335,2	129,5	330,8	137,4
	10	85	388,4	90,4	380,3	98,3	372,8	107,6	364,4	118,3	356,7	130,4	351,9	138,2
	15	85	441,8	92,2	430,9	100,1	420,8	109,4	410,6	120,1	400,3	132,2	393,6	140,1
	20	85	500,9	94,2	488,1	102,2	475,1	111,6	462,1	122,4	448,9	134,4	-	-

Tuc = Condenser outlet water temperature(ΔT inlet/outlet = $5^\circ C$).

Ta = Dry bulb external air temperature.

RH = Relative humidity.

QT = Heating capacity (evaporator fouling factor of $0,35 \times 10^{-4} \text{ m}^2\text{C/W}$).

P = Total absorbed electrical power (compressor and fan).

N.B.:

For the various PUMP and TANK & PUMP versions, add the electrical power values absorbed by the motor-driven pumps and show in tables "A" to the total absorbed electrical power.

Table "D": THAESY cooling capacity ($\Delta T = 5^\circ C$ at the evaporator)

Model	Tue (°C)	Ta (°C)											
		25		30		35		40		43		46	
		QF	P	QF	P	QF	P	QF	P	QF	P	QF	P
		kW	kW	kW	kW	kW	kW	kW	kW	kW	kW	kW	kW
4160	5	158,9	46,0	151,3	50,4	143,0	55,2	134,0	60,4	128,2	63,8	122,5	67,2
	7	167,9	46,9	159,8	51,3	151,0	56,1	141,8	61,4	135,9	64,7	129,9	68,2
	9	177,3	47,7	168,9	52,2	159,6	57,0	149,8	62,3	143,8	65,7	137,3	69,2
	11	186,9	48,7	178,0	53,1	168,5	57,9	158,1	63,2	151,6	66,6	-	-
	13	196,8	49,5	187,4	54,0	177,3	58,8	166,7	64,2	-	-	-	-
	15	206,7	50,5	197,1	54,9	186,3	59,7	175,5	65,1	-	-	-	-
4180	5	182,7	54,1	173,9	59,2	164,1	64,9	153,9	71,2	147,5	75,2	141,0	79,4
	7	193,7	55,1	184,0	60,2	174,0	65,9	163,2	72,2	156,4	76,2	149,8	80,5
	9	204,8	56,2	194,5	61,3	184,2	67,0	172,9	73,2	165,9	77,3	158,8	81,5
	11	216,2	57,2	205,7	62,3	194,5	68,1	182,8	74,4	175,7	78,4	-	-
	13	227,6	58,3	216,5	63,4	205,0	69,2	192,8	75,5	-	-	-	-
	15	239,4	59,3	228,0	64,5	215,9	70,3	203,0	76,6	-	-	-	-
4200	5	199,9	61,0	189,3	66,7	178,2	72,9	167,0	79,8	160,4	84,2	153,3	88,9
	7	211,5	62,2	200,3	67,9	189,0	74,2	177,5	81,0	170,4	85,4	162,8	90,0
	9	223,3	63,5	211,8	69,2	200,2	75,4	188,1	82,2	180,4	86,6	173,0	91,2
	11	235,7	64,8	223,9	70,5	211,7	76,8	198,9	83,6	191,1	87,9	-	-
	13	248,6	66,1	235,7	71,8	223,2	78,1	209,8	84,9	-	-	-	-
	15	261,4	67,5	248,3	73,2	235,1	79,5	221,3	86,3	-	-	-	-
4230	5	224,6	68,7	212,6	75,0	200,3	81,8	187,6	89,1	179,4	93,8	171,2	98,7
	7	237,0	70,1	224,9	76,3	212,0	83,1	198,5	90,5	190,4	95,1	181,7	99,9
	9	250,5	71,5	237,7	77,7	224,1	84,5	210,2	91,8	201,5	96,4	192,6	101,2
	11	264,0	72,9	250,9	79,1	236,5	85,9	221,9	93,2	212,9	97,8	-	-
	13	278,0	74,4	264,1	80,6	249,3	87,4	234,0	94,6	-	-	-	-
	15	292,4	75,9	277,7	82,1	262,1	88,9	246,0	96,1	-	-	-	-
4260	5	255,0	75,0	242,1	81,6	228,7	88,6	214,2	96,3	205,0	101,2	195,7	106,3
	7	269,9	76,4	256,7	82,8	242,0	89,9	226,7	97,5	217,3	102,4	207,7	107,4
	9	285,4	77,7	270,9	84,2	255,8	91,2	240,1	98,8	230,4	103,6	219,7	108,5
	11	300,9	79,1	286,0	85,6	270,0	92,6	253,5	100,1	243,1	104,9	-	-
	13	316,9	80,6	301,1	87,0	284,3	94,0	266,9	101,5	-	-	-	-
	15	332,9	82,0	316,7	88,5	299,5	95,5	281,1	102,9	-	-	-	-
4290	5	292,2	89,7	277,0	97,9	261,5	106,6	245,0	116,1	234,7	122,2	224,3	128,5
	7	309,3	91,3	293,3	99,4	277,0	108,2	259,6	117,6	248,6	123,7	238,0	130,0
	9	326,1	93,1	310,1	101,1	293,0	109,9	274,6	119,4	263,4	125,4	251,6	131,5
	11	344,3	94,9	327,0	102,9	308,9	111,6	290,2	121,1	278,2	127,0	-	-
	13	362,2	96,7	344,4	104,8	325,4	113,4	305,7	122,9	-	-	-	-
	15	381,0	98,6	362,3	106,7	342,3	115,3	321,7	124,7	-	-	-	-
4320	5	321,7	101,0	304,7	110,0	287,5	119,8	269,0	130,5	257,5	137,2	245,8	144,2
	7	340,1	103,0	322,7	112,0	304,0	121,8	284,5	132,4	272,6	139,2	260,1	146,0
	9	359,2	105,0	340,7	114,0	321,0	123,9	300,9	134,5	288,3	141,2	275,4	148,1
	11	378,8	107,1	359,4	116,2	339,1	126,1	317,4	136,7	304,4	143,3	-	-
	13	399,2	109,4	378,6	118,5	356,7	128,4	334,4	138,9	-	-	-	-
	15	419,6	111,8	397,9	120,9	375,4	130,8	352,0	141,3	-	-	-	-

Ta = Dry bulb external air temperature.

Tue = Evaporator outlet water temperature (ΔT inlet/outlet = $5^\circ C$).

QF = Cooling capacity (evaporator fouling factor of $0.35 \times 10^{-4} \text{ m}^2\text{C/W}$).

P = Total absorbed electrical power (compressor and fan).

N.B.:

For the various PUMP and TANK & PUMP versions, add the electrical power values absorbed by the motor-driven pumps and show in tables "A" to the total absorbed electrical power.

Table "D": THAESY heating capacity($\Delta T = 5^\circ C$ at the condenser)

Model	Ta (°C)	RH (%)	Tuc (°C)											
			30		35		40		45		50		53	
			QT kW	P kW	QT kW	P kW	QT kW	P kW	QT kW	P kW	QT kW	P kW	QT kW	P kW
4160	-5	90	123,4	38,0	122,2	42,0	121,3	46,5	-	-	-	-	-	-
	0	90	140,7	38,5	138,9	42,6	137,5	47,2	135,8	52,2	-	-	-	-
	7	90	167,5	39,5	165,0	43,6	162,6	48,2	160,0	53,3	157,3	59,1	155,6	62,8
	10	85	179,1	40,0	176,4	44,0	173,5	48,6	170,5	53,7	167,2	59,5	165,2	63,3
	15	85	203,2	41,0	199,6	44,8	195,6	49,3	191,6	54,5	187,5	60,3	184,9	64,1
	20	85	229,9	42,1	225,5	45,7	220,2	50,1	215,2	55,1	210,2	60,9	-	-
4180	-5	90	141,6	45,6	139,9	50,0	138,4	55,1	-	-	-	-	-	-
	0	90	162,0	46,4	159,5	50,8	157,1	56,0	155,1	62,0	-	-	-	-
	7	90	193,4	47,6	189,8	52,0	186,5	57,3	183,0	63,3	180,1	70,1	177,9	74,6
	10	85	207,1	48,1	203,1	52,5	199,1	57,8	195,0	63,8	191,3	70,6	189,1	75,1
	15	85	235,0	49,2	229,7	53,6	224,8	58,8	219,3	64,8	214,2	71,6	211,6	76,1
	20	85	265,9	50,3	259,6	54,6	253,2	59,8	246,8	65,7	240,3	72,5	-	-
4200	-5	90	163,0	50,5	160,8	55,1	159,0	61,0	-	-	-	-	-	-
	0	90	186,5	51,4	183,4	56,2	180,9	62,0	178,6	68,9	-	-	-	-
	7	90	223,1	52,8	218,6	57,6	214,5	63,4	211,0	70,3	207,7	78,1	205,8	83,4
	10	85	239,0	53,4	234,2	58,2	229,3	64,0	225,3	70,9	221,3	78,7	219,1	83,8
	15	85	270,7	54,5	265,3	59,4	259,3	65,2	253,8	72,0	248,2	79,8	245,5	84,9
	20	85	306,8	55,7	299,8	60,6	292,7	66,5	286,0	73,3	278,7	81,0	-	-
4230	-5	90	180,7	56,3	178,8	61,7	177,2	68,3	-	-	-	-	-	-
	0	90	205,8	57,3	203,3	62,7	200,4	69,2	198,0	76,9	-	-	-	-
	7	90	245,2	58,7	241,1	64,2	237,0	70,7	233,0	78,2	228,9	86,8	226,6	92,4
	10	85	262,5	59,3	257,8	64,8	253,1	71,3	248,3	78,8	244,0	87,3	241,1	92,9
	15	85	297,5	60,6	291,2	66,1	285,3	72,6	278,7	80,1	273,2	88,4	269,2	93,9
	20	85	336,4	61,8	328,8	67,4	321,1	73,9	313,8	81,3	305,3	89,8	-	-
4260	-5	90	205,0	64,9	203,6	71,0	201,5	78,3	-	-	-	-	-	-
	0	90	233,8	65,9	230,8	72,0	227,6	79,2	224,3	87,5	-	-	-	-
	7	90	279,0	67,5	273,9	73,6	268,7	80,7	264,0	88,9	258,5	98,1	255,6	104,1
	10	85	298,2	68,2	292,5	74,3	287,3	81,4	281,3	89,5	275,2	98,7	271,4	104,7
	15	85	337,8	69,5	330,2	75,6	323,1	82,7	315,8	90,8	307,7	99,9	302,9	105,8
	20	85	381,1	71,0	372,9	77,1	363,7	84,3	354,3	92,3	344,1	101,3	-	-
4290	-5	90	234,7	73,1	232,1	80,3	230,1	88,7	-	-	-	-	-	-
	0	90	268,5	74,3	264,7	81,4	260,8	89,7	257,1	99,1	-	-	-	-
	7	90	320,9	76,1	314,5	83,1	308,6	91,3	303,0	100,7	297,3	111,3	293,7	118,2
	10	85	343,4	76,9	337,0	83,9	329,7	92,1	323,0	101,5	316,2	112,0	311,3	118,9
	15	85	389,8	78,5	381,2	85,5	372,4	93,7	363,5	103,1	354,5	113,6	348,8	120,5
	20	85	441,7	80,3	431,5	87,4	420,4	95,6	409,2	105,0	397,1	115,5	-	-
4320	-5	90	257,2	81,5	254,9	89,8	253,2	99,4	-	-	-	-	-	-
	0	90	293,3	82,6	289,6	90,8	286,1	100,3	283,3	111,0	-	-	-	-
	7	90	350,4	84,5	344,3	92,5	338,9	101,8	333,0	112,5	327,0	124,5	324,2	132,4
	10	85	375,1	85,3	368,6	93,3	361,9	102,6	354,4	113,3	347,6	125,3	343,9	133,2
	15	85	426,1	87,0	417,0	95,0	408,6	104,3	399,3	115,0	389,9	127,0	384,5	134,9
	20	85	482,8	89,0	471,8	97,0	460,7	106,4	449,4	117,1	437,2	129,2	-	-

Tuc = Condenser outlet water temperature(ΔT inlet/outlet = $5^\circ C$).

Ta = Dry bulb external air temperature.

RH = Relative humidity.

QT = Heating capacity (evaporator fouling factor of $0.35 \times 10^{-4} \text{ m}^2\text{C/W}$).

P = Total absorbed electrical power (compressor and fan).

N.B.:

For the various PUMP and TANK & PUMP versions, add the electrical power values absorbed by the motor-driven pumps and show in tables "A" to the total absorbed electrical power.

Pressure drops

Graph "1": heat exchanger pressure drops

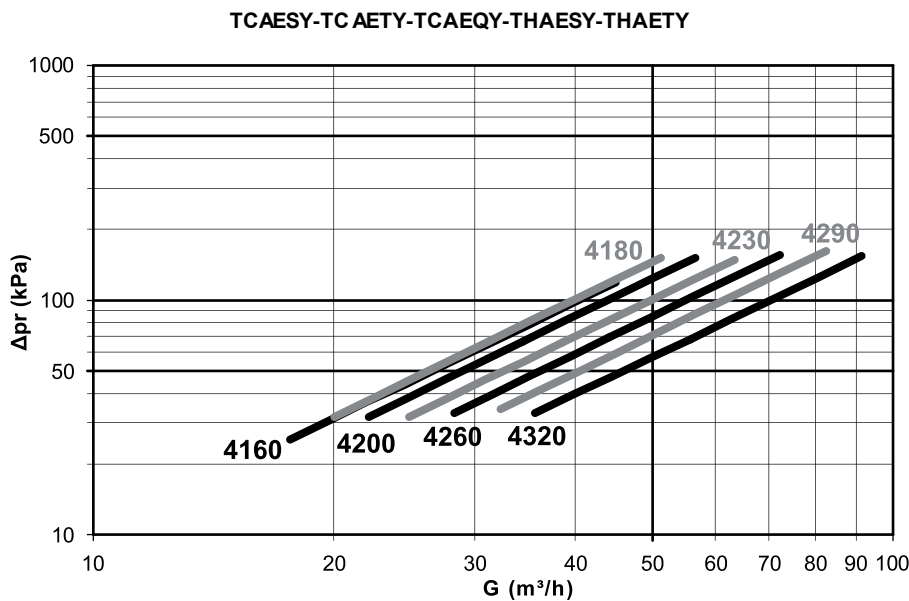
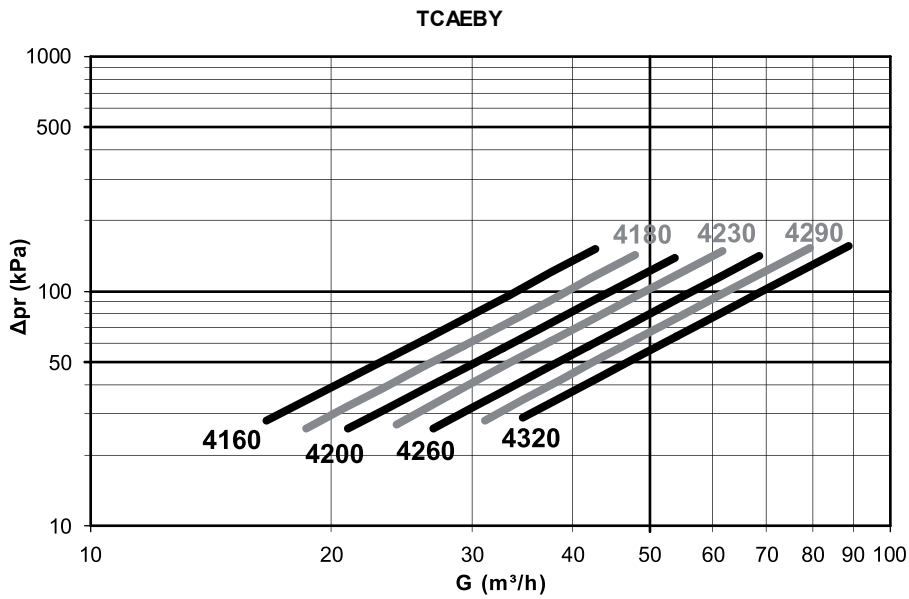

Calculation of pressure drops

○ The water flow rate at the exchanger is calculated according to the following formula:

$$G = (Q \times 0.86) : \Delta T$$

• Where:

G (m³/h) = water flow rate at the exchanger;

Q (kW) = exchanged power, which may be QF (for the evaporator) or QT (for the condenser), depending on the exchanger in question;

ΔT (°C) = temperature differential;

○ The pressure drops can be obtained from the *RHOSS* selection software and can be read on the graph to the side, or can be calculated using the following rough formula:

$$\Delta p_w = \Delta p_{w_{nom}} \times (G : G_{nom})^2$$

Δpw (kPa) = nominal pressure drop at the exchanger in question (table on *Technical data*):

G (m³/h) = water flow rate at the exchanger in question.

N.B.:

For all machines, refer in any case to admissible operating limits and thermal differences (ΔT).

Residual static pressure

Graph "2": residual static pressure

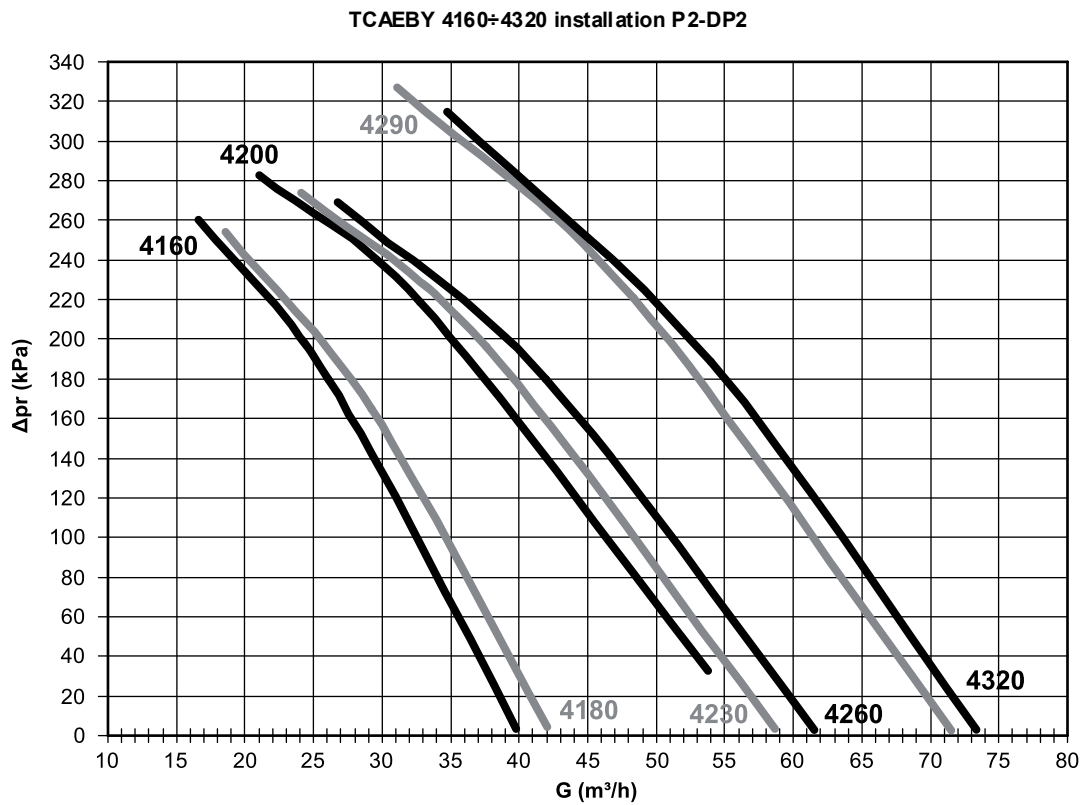
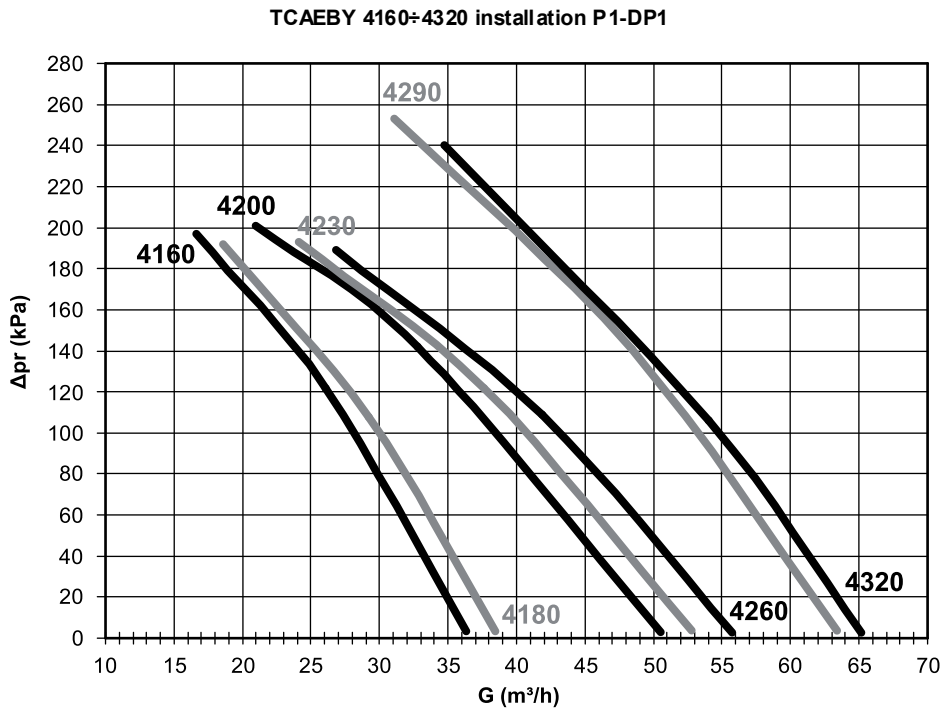

TCAETY-TCAESY-TCAEQY-THAETY-THAESY 4160÷4320 installation P1-DP1

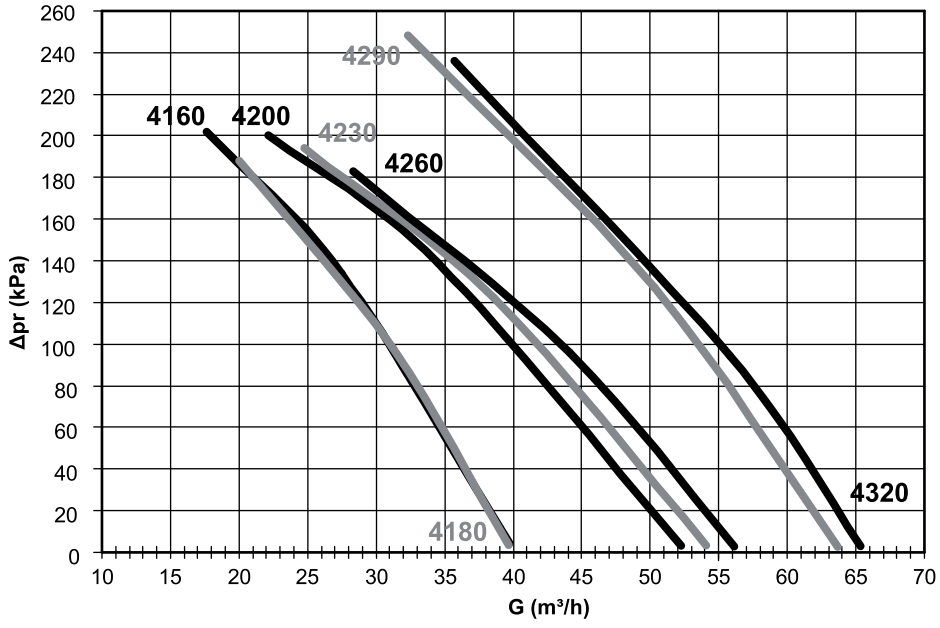

THAETY-THAESY - TC AETY-TCAESY-TCAEQY 4160÷4320 installation P2-DP2

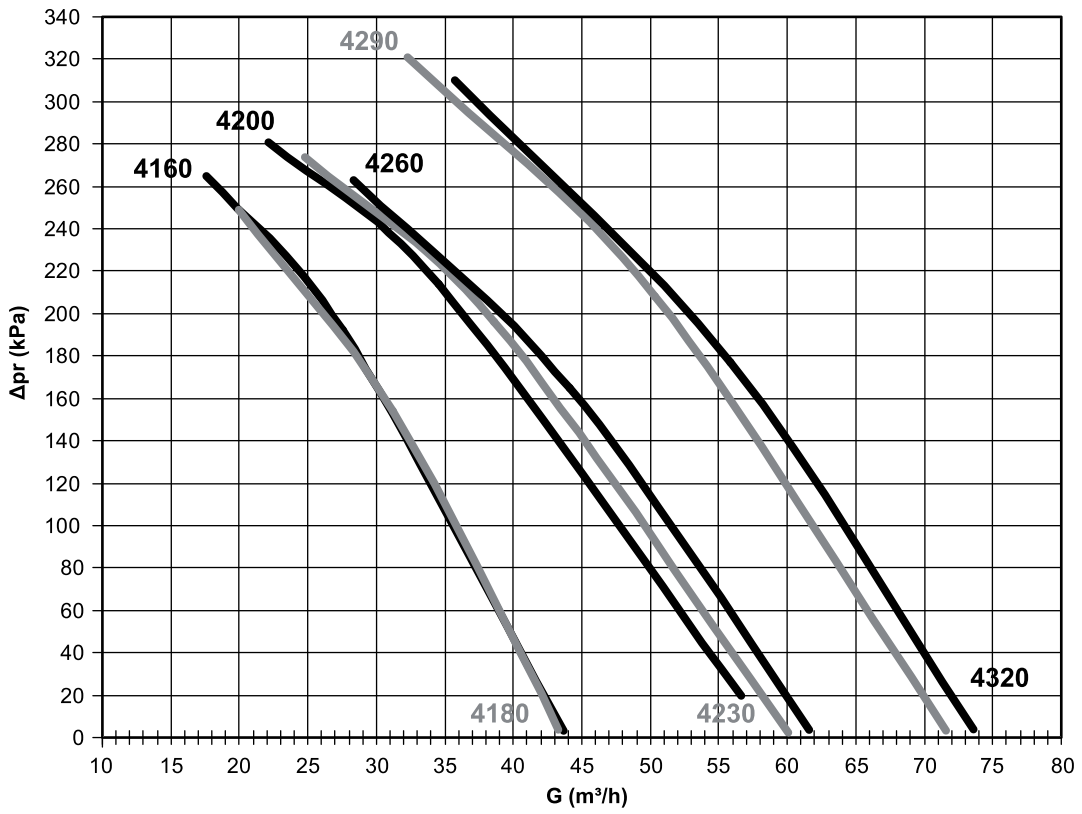

TCAEBY 4160÷4320 installation ASP1-ASDP1

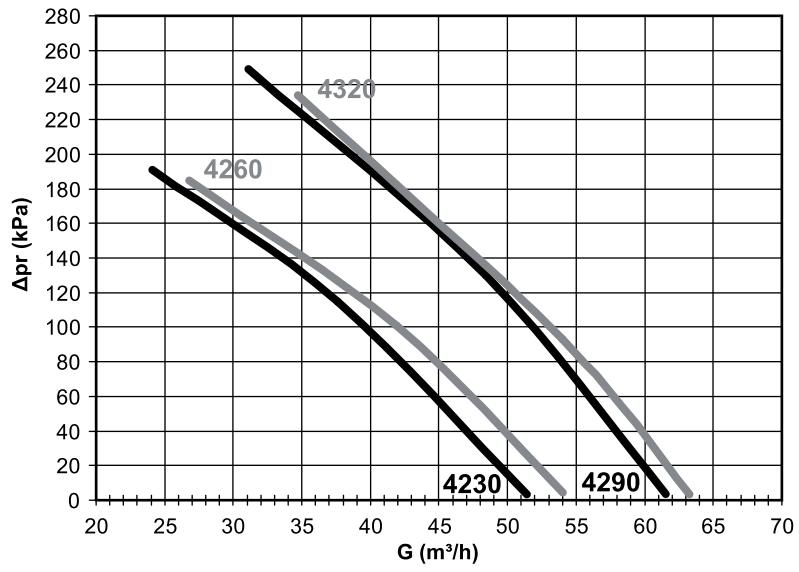

TCAEBY 4160÷4320 installation ASP2-ASDP2

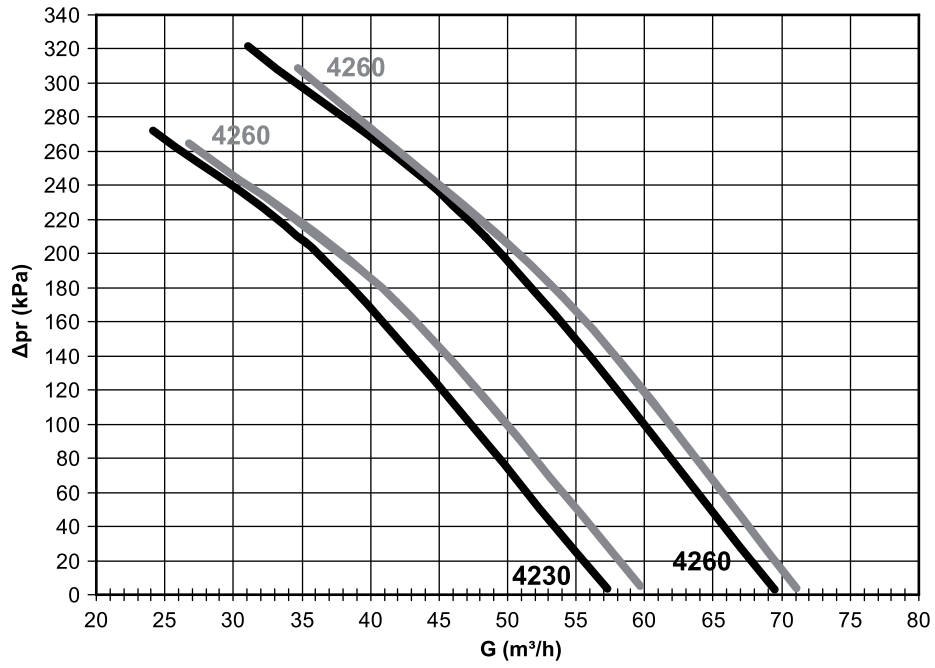

THAETY-THAESY - TC AETY-TCAESY-TCAEQY 4160÷4320 installation ASP1-ASDP1

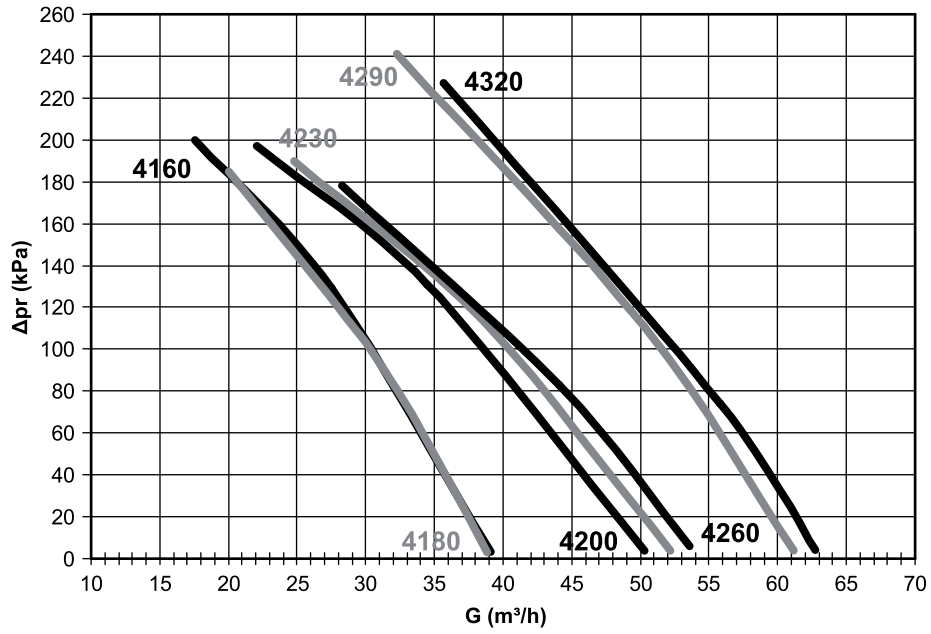

THAETY-THAESY - TC AETY-TCAESY-TCAEQY 4160÷4320 installation ASP2-ASDP2

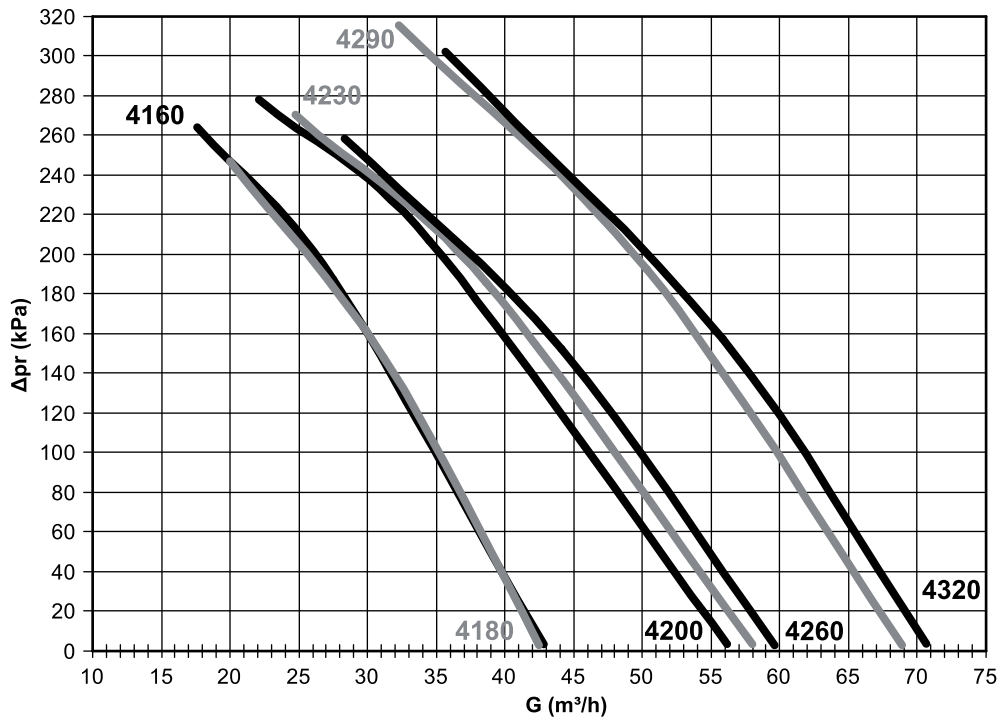

Δpr (kPa) = Residual static pressure

G (l/h) = Water flow

Calculation of residual static pressure

The residual static pressure values can be obtained from graph "2" based on measured flow rates.

Power levels and sound pressure

Model		Sound power level in dB by octave bands							Pressure level in dB(A)			
		125 Hz	250 Hz	500 Hz	1000 Hz	2000 Hz	4000 Hz	8000 Hz	Lw dB(A)	Lp 10m	Lp 5m	Lp 1m
TCAEY (*)	4160	83	82	85	88	83	75	67	90	62	66	72
	4180	85	84	87	90	85	77	70	92	64	70	74
	4200	85	84	87	90	85	77	70	92	64	70	74
	4230	87	85	89	91	88	80	72	94	66	72	76
	4260	87	85	89	91	88	80	72	94	66	72	76
	4290	88	87	90	92	89	81	74	95	68	74	78
	4320	88	87	90	92	89	81	74	95	68	74	78
TCAEY THAEY	4160	90	84	83	82	78	69	63	86	57	63	72
	4180	86	82	85	89	84	76	69	91	63	67	73
	4200	86	82	85	89	84	76	69	91	63	67	73
	4230	87	83	86	90	85	77	70	92	64	68	74
	4260	88	84	87	90	86	78	71	93	65	69	75
	4290	88	84	87	90	86	78	71	93	65	69	75
	4320	88	84	87	90	86	78	71	93	65	69	75
TCAEY THAESY	4160	83	81	81	79	72	63	54	83	53	59	68
	4180	80	78	82	84	78	70	64	86	56	61	68
	4200	80	78	82	84	78	70	64	86	56	61	68
	4230	81	79	83	85	79	73	66	87	57	62	69
	4260	83	81	85	87	81	75	68	89	59	64	71
	4290	83	81	85	87	81	75	68	89	59	64	71
	4320	83	81	85	87	81	75	68	89	59	64	71
TCAEQY	4160	82	80	79	76	70	61	53	80	50	56	65
	4180	83	81	81	79	72	63	54	83	53	58	68
	4200	83	81	81	79	72	63	54	83	53	58	68
	4230	85	83	81	80	73	64	55	84	54	59	69
	4260	86	84	82	81	75	65	57	85	55	60	70
	4290	86	84	82	81	75	65	57	85	55	60	70

Lw Sound power level in dB(A) on the basis of measurements made in compliance with the UNI EN-ISO 3744 standard and Eurovent 8/1.
The noise measurement refers to the units without pump.

Lp Sound pressure level in dB(A) in reference to the measurement and distance from the unit indicated in the table, with directionality factor of 2.
The noise measurement refers to the units without pump.

(*) If the BCI accessory (soundproofed compressor box) is present, the sound power level Lw is reduced by 2 dB(A).
If the SIL accessory (soundproofing) is present, the sound power level Lw is reduced by 6 dB(A).

Note: With an external air temperature of under 35°C in the presence of the FI10 accessory (as standard in versions S and Q), the machine noise levels fall to below the nominal value indicated in the table.
It is not possible to extrapolate sound pressure values for distances of under 10 m.

Operating limits

Summer operation

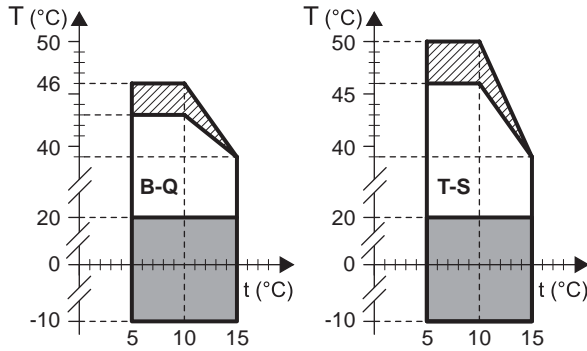

- Operati on with condensati on control F110 (as standard in Q and S versions)
- Operati on with stepped cooling capacity.

T (°C) = Air temperature (D.B.).
t (°C) = Water temperature

In summer mode:

Maxi mum inlet water temperature 20°C.

Temperature differentials permitted through the exchangers

o Temperature differential at the evaporator $\Delta T = 3 \div 8^\circ\text{C}$ (with both compressors on) for machines with "standard" installation. The maximum and minimum temperature differential for the "Pump" and "Tank&Pump" machines is linked to the pump performances, which must always be checked with the help of the graphs on page 29 or using the *RHOSS* selection software.

- o Minimum water pressure 0.5 Barg
- o Maxi mum water pressure 6 Barg.
- o Maxi mum water pressure on heat recovery and desuperheater 3 Barg.

N.B.:

For evaporator outlet water of a temperature below 5°C, please contact the *RHOSS* S.p.A. pre-sales service before ordering.

Winter operation

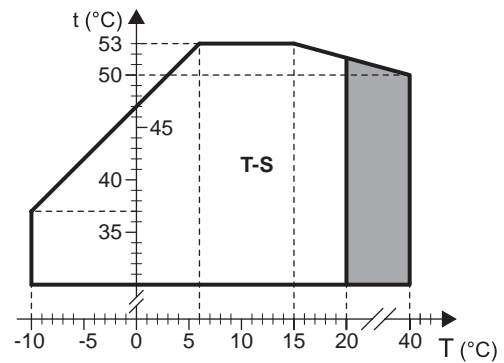

T (°C) = Air temperature (D.B.).
t (°C) = Water temperature

In winter operation:

Maxi mum inlet water temperature 47°C

Model	TCAEBY (*)	TCAETY-THAETY-TCAESY-THAESY	TCAESY-THAESY	TCAEQY
4160÷4320	$T_{max} = 43^\circ\text{C}$ (1)(2)	$T_{max} = 46^\circ\text{C}$ (1)(2)	$T_{max} = 40^\circ\text{C}$ (1)(3)	$T_{max} = 37^\circ\text{C}$ (1)(3)
	$T_{max} = 46^\circ\text{C}$ (1)(4)	$T_{max} = 50^\circ\text{C}$ (1)(4)	-	$T_{max} = 43^\circ\text{C}$ (1)(2)
	-	-	-	$T_{max} = 46^\circ\text{C}$ (1)(4)

- (1) Water temperature (IN/OUT) 12/7 °C.
- (2) Maxi mum external air temperature with unit in standard operation at full load and not silenced.
- (3) Maxi mum external air temperature with unit in silenced mode.
- (4) Maxi mum external air temperature with unit with shuttered cooling capacity.
- (*) With the SIL accessory (silenced installation), the maximum external air temperature with the unit in silenced mode is 40°C.

Use of anti-freeze solutions

o The use of ethylene glycol is recommended if you do not wish to drain the water from the hydraulic system during the winter stoppage, or if the unit has to supply chilled water at temperatures lower than 5°C. The addition of glycol changes the physical properties of the water and consequently the performance of the unit. The proper percentage of glycol to be added to the system can be obtained from the most demanding operating conditions from those shown below.

- o Table "H" shows the multipliers which allow the changes in performance of the units to be determined in proportion to the required percentage of ethylene glycol.
 - The multipliers refer to the following conditions: condenser inlet water temperature 35°C; chilled water outlet temperature 7°C; temperature differential at evaporator and condenser 5°C.
 - For different operating conditions, the same coefficients can be used as their variations are negligible.

o The electric heater for the water side heat exchanger (RA accessory), the water buffer tank (RAS accessory), the motor-driven pump assembly (RAE accessory) and the desuperheater or heat recovery (RDR accessory) prevents ice formation during winter breaks (as long as the unit is not disconnected from the power supply).

Attention:

Over 20% glycol, check the pump absorption limits (in versions P1-P2, DP1-DP2, ASP1-ASP2, ASDP1-ASDP2).

Table "H"

% glycol in weight	10 %	15 %	20 %	25 %	30 %
Freezing temperature °C	-5	-7	-10	-13	-16
fc QF	0,991	0,987	0,982	0,978	0,974
fc P	0,996	0,995	0,993	0,991	0,989
fc Δpw	1,053	1,105	1,184	1,237	1,316
fc G	1,008	1,028	1,051	1,074	1,100

fc QF = Cooling capacity correction factor.

fc P = Correction factor for the absorbed electrical current.

fc Δpw = Correction factor of the pressure drops in the evaporator

fc G = Correction factor of the glycol water flow to the evaporator

RC100 and DS accessories: performances and pressure drops

Table "G": Performance and pressure drops RC100 accessory for TC AETY-TCAESY-TCAEQY models

RC100 - 100% recovery		4160			4180		
Water inlet/outlet temperature	°C	35/40 (**)	40/45 (*)	45/50 (**)	35/40 (**)	40/45 (*)	45/50 (**)
Nominal heating capacity (*)	kW	225,5	220,4	215,2	254,6	248,8	243,5
Recovery nominal flow	m ³ /h	39,2	38,4	38,2	44,3	43,3	43,3
Recovery nominal pressure drops	kPa	81,5	78,5	77,9	101,4	97,7	97,4
Recovery water content	l		16			16	
RC100 - 100% recovery		4200			4230		
Water inlet/outlet temperature	°C	35/40 (**)	40/45 (*)	45/50 (**)	35/40 (**)	40/45 (*)	45/50 (**)
Nominal heating capacity (*)	kW	283,7	277,1	270,9	319,8	312,3	304,6
Recovery nominal flow	m ³ /h	49,3	48,3	48,1	55,6	54,4	54,1
Recovery nominal pressure drops	kPa	104,8	100,8	100,4	105,0	100,9	100,0
Recovery water content	l		18			21	
RC100 - 100% recovery		4260			4290		
Water inlet/outlet temperature	°C	35/40 (**)	40/45 (*)	45/50 (**)	35/40 (**)	40/45 (*)	45/50 (**)
Nominal heating capacity (*)	kW	360,5	351,6	342,5	413,1	403,0	392,9
Recovery nominal flow	m ³ /h	62,7	61,2	60,9	71,8	70,2	69,8
Recovery nominal pressure drops	kPa	108,2	103,8	102,6	111,8	107,3	106,2
Recovery water content	l		23			26	
RC100 - 100% recovery		4320					
Water inlet/outlet temperature	°C	35/40 (**)	40/45 (*)	45/50 (**)			
Nominal heating capacity (*)	kW	462,8	452,3	440,8			
Recovery nominal flow	m ³ /h	80,5	78,8	78,3			
Recovery nominal pressure drops	kPa	109,7	105,6	104,5			
Recovery water content	l		31				

Table "G": Performance and pressure drops RC100 accessory for THAETY-THAESY models

RC100 - 100% recovery		4160			4180		
Water inlet/outlet temperature	°C	35/40 (**)	40/45 (*)	45/50 (**)	35/40 (**)	40/45 (*)	45/50 (**)
Nominal heating capacity (*)	kW	222,3	217,2	212,1	252,5	246,7	241,5
Recovery nominal flow	m ³ /h	38,6	37,8	37,7	43,9	43,0	42,9
Recovery nominal pressure drops	kPa	79,5	76,5	75,9	99,9	96,2	95,9
Recovery water content	l	16			16		
RC100 - 100% recovery		4200			4230		
Water inlet/outlet temperature	°C	35/40 (**)	40/45 (*)	45/50 (**)	35/40 (**)	40/45 (*)	45/50 (**)
Nominal heating capacity (*)	kW	281,5	275,0	268,9	315,5	308,0	300,5
Recovery nominal flow	m ³ /h	48,9	47,9	47,8	54,9	53,7	53,4
Recovery nominal pressure drops	kPa	103,4	99,5	99,0	102,5	98,5	97,6
Recovery water content	l	18			21		
RC100 - 100% recovery		4260			4290		
Water inlet/outlet temperature	°C	35/40 (**)	40/45 (*)	45/50 (**)	35/40 (**)	40/45 (*)	45/50 (**)
Nominal heating capacity (*)	kW	357,3	348,5	339,5	408,8	398,8	388,8
Recovery nominal flow	m ³ /h	62,1	60,7	60,3	71,1	69,5	69,1
Recovery nominal pressure drops	kPa	106,5	102,1	101,0	109,7	105,3	104,3
Recovery water content	l	23			23		
RC100 - 100% recovery		4320					
Water inlet/outlet temperature	°C	35/40 (**)	40/45 (*)	45/50 (**)			
Nominal heating capacity (*)	kW	454,2	443,9	432,6			
Recovery nominal flow	m ³ /h	79,0	77,3	76,9			
Recovery nominal pressure drops	kPa	106,0	102,1	101,0			
Recovery water content	l	31					

(•) Heating capacity with recovery and desuperheater fouling factor equivalent to $0.35 \times 10^{-4} \text{ m}^2 \text{ K/W}$.

(*) Conditions referred to the unit complete with condensation control (F110) with standard calibration, chilled water temperature of 7°C and evaporator temperature differential of 5K.

(**) Conditions refer to the unit complete with condensation control (F110), with suitable calibration (expressly requested when the order is made), chilled water temperature of 7°C and temperature difference at the evaporator of 5K.

Operating limits:

RC100:

- hot water temperature of 35-50°C with permitted water temperature differential of 4-6K;
- the minimum permitted water inlet temperature is 30°C.

Attention

Units fitted with a permanent recovery unit or desuperheater in series with the compressor must be used in compliance with the regulations set out by Ministerial Decree 1/12/1975 "Safety regulations for appliances containing hot pressurized fluids" and by its technical application specifications (collections R and H). This law is only valid in the Italian Republic. In the event of installation in other countries, please keep to the local laws in force. Hot water for domestic use can be produced only with the use of an additional heat exchanger which is suited to the purpose. Refer to current laws and standards in the place of installation.

Table "G": Performance and pressure drops DS accessory for TC AETY models

DS - Desuperheater		4160		4180	
Water inlet/outlet temperature	°C	50/60 (*)	60/70 (*)	50/60 (*)	60/70 (*)
Nominal heating capacity (•)	kW	46,6	36,6	49,9	39,2
Desuperheater nominal water flow	m³/h	4,1	3,2	4,4	3,4
Desuperheater nominal pressure drops	kPa	4,1	2,6	4,6	3,0
Desuperheater water content.	l	5		5	

DS - Desuperheater		4200		4230	
Water inlet/outlet temperature	°C	50/60 (*)	60/70 (*)	50/60 (*)	60/70 (*)
Nominal heating capacity (•)	kW	53,3	42,5	62,7	50,0
Desuperheater nominal water flow	m³/h	4,7	3,7	5,5	4,4
Desuperheater nominal pressure drops	kPa	5,2	3,5	3,3	2,2
Desuperheater water content.	l	5		8	

DS - Desuperheater		4260		4290	
Water inlet/outlet temperature	°C	50/60 (*)	60/70 (*)	50/60 (*)	60/70 (*)
Nominal heating capacity (•)	kW	74,3	59,1	81,9	65,0
Desuperheater nominal water flow	m³/h	6,5	5,2	7,2	5,7
Desuperheater nominal pressure drops	kPa	4,4	2,9	5,3	3,5
Desuperheater water content.	l	8		8	

DS - Desuperheater		4320	
Water inlet/outlet temperature	°C	50/60 (*)	60/70 (*)
Nominal heating capacity (•)	kW	87,2	70,2
Desuperheater nominal water flow	m³/h	7,6	6,2
Desuperheater nominal pressure drops	kPa	5,9	4,0
Desuperheater water content.	l	8	

Table "G": Performance and pressure drops DS accessory for TC AESY models

DS - Desuperheater		4160		4180	
Water inlet/outlet temperature	°C	50/60 (*)	60/70 (*)	50/60 (*)	60/70 (*)
Nominal heating capacity (•)	kW	44,7	35,8	49,0	39,0
Desuperheater nominal water flow	m³/h	3,9	3,1	4,3	3,4
Desuperheater nominal pressure drops	kPa	3,8	2,5	4,5	3,0
Desuperheater water content.	l	5		5	

DS - Desuperheater		4200		4230	
Water inlet/outlet temperature	°C	50/60 (*)	60/70 (*)	50/60 (*)	60/70 (*)
Nominal heating capacity (•)	kW	51,1	41,3	60,6	48,9
Desuperheater nominal water flow	m³/h	4,5	3,6	5,3	4,3
Desuperheater nominal pressure drops	kPa	4,8	3,3	3,1	2,1
Desuperheater water content.	l	5		8	

DS - Desuperheater		4260		4290	
Water inlet/outlet temperature	°C	50/60 (*)	60/70 (*)	50/60 (*)	60/70 (*)
Nominal heating capacity (•)	kW	71,1	57,2	78,6	63,1
Desuperheater nominal water flow	m³/h	6,2	5,0	6,9	5,5
Desuperheater nominal pressure drops	kPa	4,1	2,8	4,9	3,3
Desuperheater water content.	l	8		8	

DS - Desuperheater		4320	
Water inlet/outlet temperature	°C	50/60 (*)	60/70 (*)
Nominal heating capacity (•)	kW	82,9	67,6
Desuperheater nominal water flow	m³/h	7,3	5,9
Desuperheater nominal pressure drops	kPa	5,4	3,7
Desuperheater water content.	l	8	

Table "G": Performance and pressure drops DS accessory for TC AEQY models

DS - Desuperheater		4160		4180	
Water inlet/outlet temperature	°C	50/60 (*)	60/70 (*)	50/60 (*)	60/70 (*)
Nominal heating capacity (*)	kW	40,4	33,8	45,8	37,4
Desuperheater nominal water flow	m³/h	3,5	3,0	4,0	3,3
Desuperheater nominal pressure drops	kPa	3,2	2,3	4,0	2,7
Desuperheater water content.	l	5		5	

DS - Desuperheater		4200		4230	
Water inlet/outlet temperature	°C	50/60 (*)	60/70 (*)	50/60 (*)	60/70 (*)
Nominal heating capacity (*)	kW	48,0	40,0	59,5	48,1
Desuperheater nominal water flow	m³/h	4,2	3,5	5,2	4,2
Desuperheater nominal pressure drops	kPa	4,3	3,1	3,0	2,0
Desuperheater water content.	l	5		8	

DS - Desuperheater		4260		4290	
Water inlet/outlet temperature	°C	50/60 (*)	60/70 (*)	50/60 (*)	60/70 (*)
Nominal heating capacity (*)	kW	65,8	54,0	72,4	60,3
Desuperheater nominal water flow	m³/h	5,8	4,7	6,3	5,3
Desuperheater nominal pressure drops	kPa	3,6	2,5	4,2	3,0
Desuperheater water content.	l	8		8	

Table "G": Performance and pressure drops DS accessory for TH AETY models

DS - Desuperheater		4160		4180	
Water inlet/outlet temperature	°C	50/60 (*)	60/70 (*)	50/60 (*)	60/70 (*)
Nominal heating capacity (*)	kW	45,6	35,7	49,9	39,2
Desuperheater nominal water flow	m³/h	4,0	3,1	4,4	3,4
Desuperheater nominal pressure drops	kPa	3,9	2,5	4,6	3,0
Desuperheater water content.	l	5		5	

DS - Desuperheater		4200		4230	
Water inlet/outlet temperature	°C	50/60 (*)	60/70 (*)	50/60 (*)	60/70 (*)
Nominal heating capacity (*)	kW	53,3	42,5	62,7	50,1
Desuperheater nominal water flow	m³/h	4,7	3,7	5,5	4,4
Desuperheater nominal pressure drops	kPa	5,2	3,5	3,3	2,2
Desuperheater water content.	l	5		8	

DS - Desuperheater		4260		4290	
Water inlet/outlet temperature	°C	50/60 (*)	60/70 (*)	50/60 (*)	60/70 (*)
Nominal heating capacity (*)	kW	74,4	59,2	80,8	64,3
Desuperheater nominal water flow	m³/h	6,5	5,2	7,1	5,6
Desuperheater nominal pressure drops	kPa	4,4	2,9	5,1	3,4
Desuperheater water content.	l	8		8	

DS - Desuperheater		4320	
Water inlet/outlet temperature	°C	50/60 (*)	60/70 (*)
Nominal heating capacity (*)	kW	85,0	68,6
Desuperheater nominal water flow	m³/h	7,4	6,0
Desuperheater nominal pressure drops	kPa	5,6	3,8
Desuperheater water content.	l	8	

Table "G": Performance and pressure drops DS accessory for THAES Y models

DS - Desuperheater		4160		4180	
Water inlet/outlet temperature	°C	50/60 (*)	60/70 (*)	50/60 (*)	60/70 (*)
Nominal heating capacity (•)	kW	44,7	35,8	49,0	39,0
Desuperheater nominal water flow	m ³ /h	3,9	3,1	4,3	3,4
Desuperheater nominal pressure drops	kPa	3,8	2,5	4,5	3,0
Desuperheater water content.	l	5		5	

DS - Desuperheater		4200		4230	
Water inlet/outlet temperature	°C	50/60 (*)	60/70 (*)	50/60 (*)	60/70 (*)
Nominal heating capacity (•)	kW	51,2	41,6	59,5	48,1
Desuperheater nominal water flow	m ³ /h	4,5	3,7	5,2	4,2
Desuperheater nominal pressure drops	kPa	4,8	3,3	3,0	2,0
Desuperheater water content.	l	5		8	

DS - Desuperheater		4260		4290	
Water inlet/outlet temperature	°C	50/60 (*)	60/70 (*)	50/60 (*)	60/70 (*)
Nominal heating capacity (•)	kW	71,1	57,3	77,5	62,4
Desuperheater nominal water flow	m ³ /h	6,2	5,0	6,8	5,5
Desuperheater nominal pressure drops	kPa	4,1	2,8	4,8	3,2
Desuperheater water content.	l	8		8	

DS - Desuperheater		4320	
Water inlet/outlet temperature	°C	50/60 (*)	60/70 (*)
Nominal heating capacity (•)	kW	80,7	66,1
Desuperheater nominal water flow	m ³ /h	7,1	5,8
Desuperheater nominal pressure drops	kPa	5,1	3,6
Desuperheater water content.	l	8	

(•) Heating capacity with recovery and desuperheater fouling factor equivalent to 0.35×10^{-4} m² K/W.

(*) Conditions refer to the unit with chilled water temperature of 7°C and temperature differential at the evaporator of 5K.

Operating limits:

DS:

- hot water temperature of 50÷70°C with permitted water temperature differential of 5÷10K;
- the minimum permitted water inlet temperature is 40°C.

Attention

Units fitted with a permanent recovery unit or desuperheater in series with the compressor must be used in compliance with the regulations set out by Ministerial Decree 1/12/1975 "Safety regulations for appliances containing hot pressurized fluids" and by its technical application specifications (collections R and H).

This law is only valid in the Italian Republic. In the event of installation in other countries, please keep to the local laws in force.

Hot water for domestic use can be produced only with the use of an additional heat exchanger which is suited to the purpose. Refer to current laws and standards in the place of installation.

TCAEBY dimensions and footprints

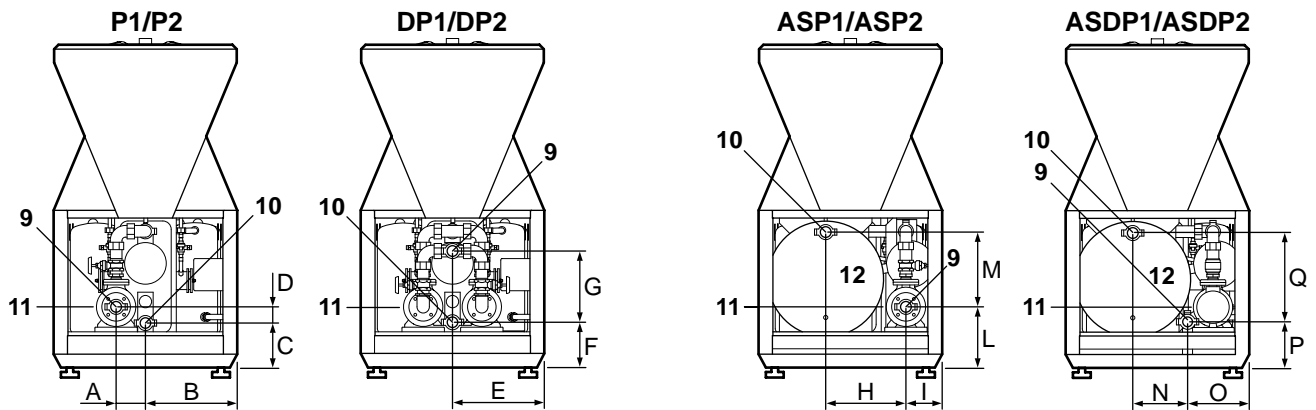
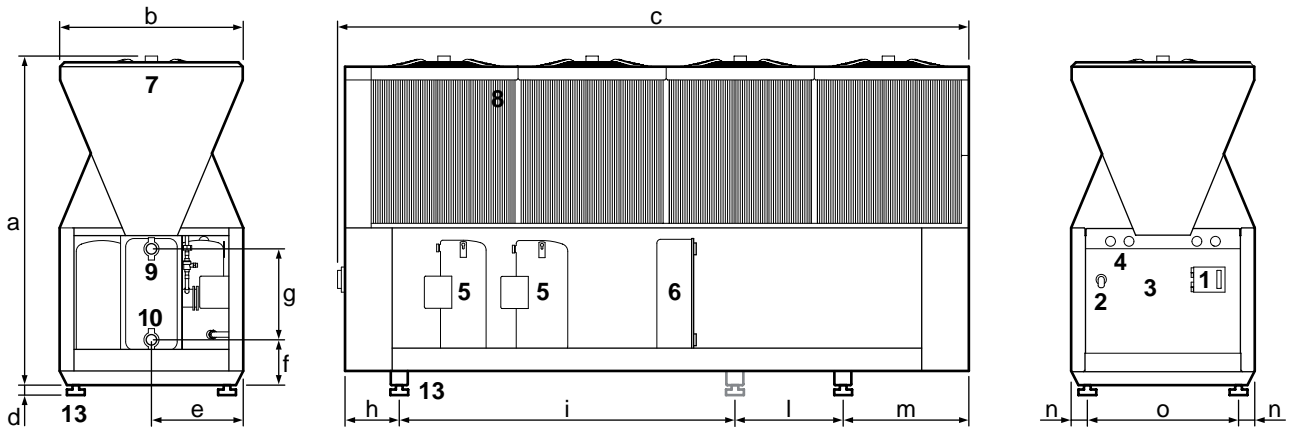

- 1. Control panel;
- 2. Isolator;
- 3. Electrical board;
- 4. Refrigerant circuit pressure gauges (GM access or y);
- 5. Compressor;
- 6. Evaporator;
- 7. Fan;
- 8. Finned coil;
- 9. Main exchanger water inlet;
- 10. Main exchanger water outlet;
- 11. Motor-driven pump;
- 12. Water buffer tank;
- 13. Anti-vibration support (KSA/KSAM accessory).

TCAEBY

Model	a	b	c	d	e	f	g	h	i	l	m	n	o
4160 mm	2135	1190	3130	80±150	595	435	455	350	2075	-	655	72	1046
4180 mm	2135	1190	3130	80±150	595	435	455	350	2075	-	655	72	1046
4200 mm	2135	1190	3130	80±150	595	295	590	350	2075	-	655	72	1046
4230 mm	2135	1190	4090	80±150	595	295	590	350	2175	700	815	72	1046
4260 mm	2135	1190	4090	80±150	595	295	590	350	2175	700	815	72	1046
4290 mm	2135	1190	5050	80±150	595	295	590	350	1725	1795	1130	72	1046
4320 mm	2135	1190	5050	80±150	595	295	590	350	1725	1795	1130	72	1046

Model	4160	4180	4200	4230	4260	4290	4320
Exchanger inlet/outlet connections	Ø 2 1/2"	Ø 2 1/2"	Ø 3"	Ø 3"	Ø 3"	Ø 3"	Ø 3"

TCAEBY

Model	A	B	C	D	E	F	G	H	I	L	M	N	O	P	Q
4160 mm	190	595	355	80	595	435	280	-	-	-	-	-	-	-	-
4180 mm	190	595	355	80	595	435	280	-	-	-	-	-	-	-	-
4200 mm	190	595	295	90	595	295	455	-	-	-	-	-	-	-	-
4230 mm	190	595	295	90	595	295	455	520	235	385	490	350	400	290	585
4260 mm	190	595	295	90	595	295	455	520	235	385	480	350	400	290	585
4290 mm	190	595	295	80	595	295	440	520	235	375	500	350	400	290	585
4320 mm	190	595	295	80	595	295	440	520	235	375	500	350	400	290	585

Model	4160	4180	4200	4230	4260	4290	4320
Exchanger inlet/outlet connections	Ø 2 1/2"	Ø 2 1/2"	Ø 3"	Ø 3"	Ø 3"	Ø 3"	Ø 3"

Clearances and positioning

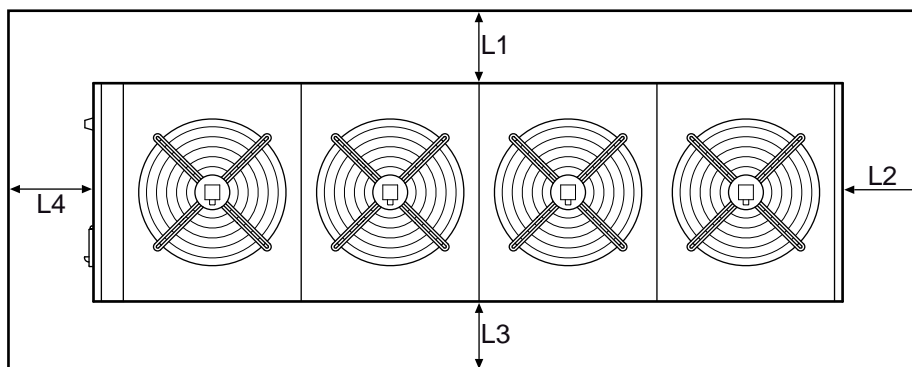

Model	4160	4180	4200	4230	4260	4290	4320
L1 mm	1500	1500	1500	1500	1500	1500	1500
L2 mm	1500	1500	1500	1500	1500	1500	1500
L3 mm	1500	1500	1500	1500	1500	1500	1500
L4 mm	1500	1500	1500	1500	1500	1500	1500

N.B.:

L2 is the minimum distance for the removal of the pump assembly and the relative water buffer tank. If the accessory is not present, the distance can be reduced.

Handling and storage

- The unit should be handled with care to avoid damage to the external structure and to the internal mechanical and electrical components.
- Do not stack the units.
- The temperature limits for storage are -9° $+45^{\circ}$ C.
- The position of the lifting belts should be checked on the basis of the model and the accessories installed.
- During lifting and handling, make sure that the unit is horizontal at all times.

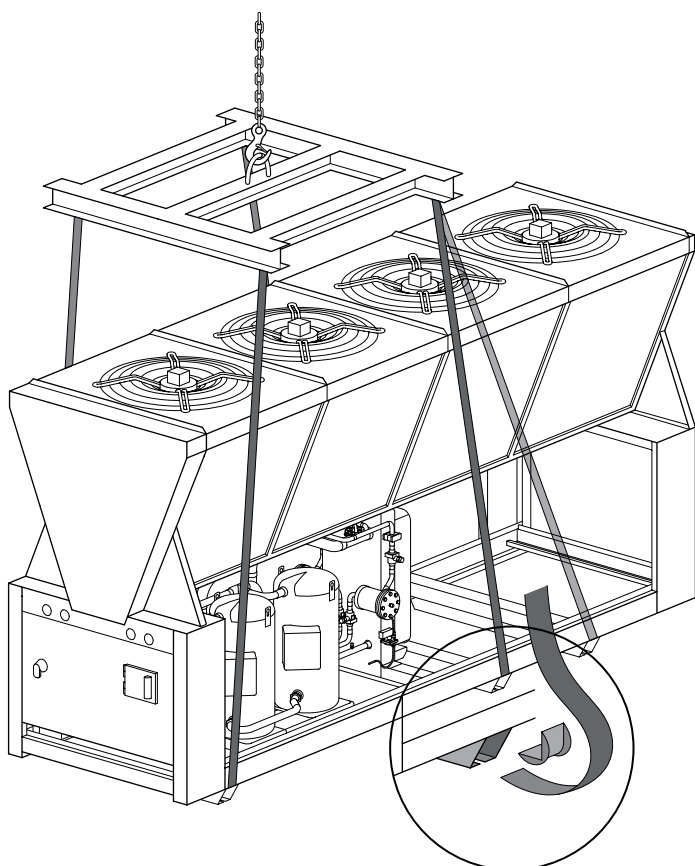

Installation and connection to the system

- The unit is designed for outdoor installation.
- The unit is fitted with Victaulic type water connections on the air conditioning system water inlet and outlet and on the recovery/desuperheater inlets and outlets. It is also fitted with carbon steel fittings for welding.
- Segregate the unit if installed in areas accessible to persons under 14 years of age.
- The unit must be positioned to comply with the minimum recommended clearances, bearing in mind the access to water and electrical connections.
- The unit can be equipped with anti-vibration mountings on request (KSA).
- Shut-off valves must be installed that isolate the unit from the rest of the system. Elastic connection joints and system/machine drain taps also need to be fitted.
- A metal mesh filter (with a mesh size of no more than 0.8 mm²), of a suitable size and with suitable pressure drops, must be fitted on unit return pipes.
- However it is installed, the coil inlet air temperature (ambient air) must remain within the set limits.
- The water flow through the heat-exchanger should not fall below a value corresponding to a temperature differential of 8°C (with both compressors on).
- The unit may not be installed on brackets or shelves.
- Correct installation and positioning include levelling the unit on a surface capable of bearing its weight.
- During long periods of inactivity, it is advisable to drain the water from the system.
- It is possible to avoid draining the water by adding ethylene glycol to the water circuit (see "Use of antifreeze solutions").
- The expansion tank is sized on the basis of the water content of the individual machine. Any additional expansion tank should be sized by the installer on the basis of the system. In the case of models without a pump, the pump must be installed with the pump delivery towards the machine water inlet.

N.B.:

The space over the unit must be free from any possible obstacle. If the unit is completely surrounded by walls, the distances specified are still valid, provided that at least two adjacent walls are not higher than the unit itself.

There must be a minimum gap of at least 3.5 m between the top of the unit and any obstacles above it.

If more than one unit is installed, the minimum distance between the finned coils should be at least 2 m.

TCAETY-TCAESY-TCAEQY-THAETY-THAESY dimensions and footprints

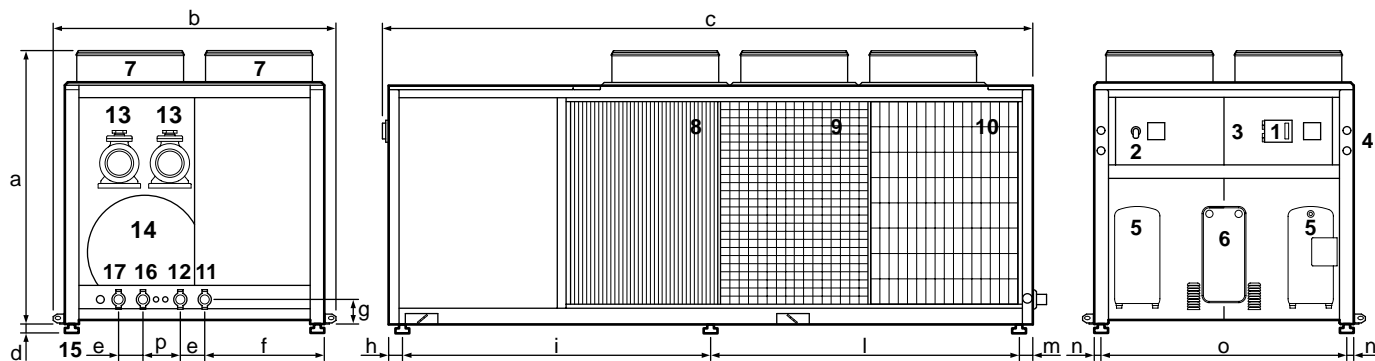

1. Control panel;
2. Isolator;
3. Electrical board;
4. Refrigerant circuit pressure gauges (GM access or y);
5. Compressor;
6. Evaporator;
7. Fan;
8. Finned coil;
9. Metal filter (FMB accessory);
10. Coil protection mesh (RPB accessory);
11. Main exchanger water inlet;
12. Main exchanger water outlet;
13. Motor-driven pump;
14. Water buffer tank;
15. Anti-vibration support (KSA/KSAM accessory);
16. Recovery water inlet (DS – RC100 accessory);
17. Recovery water inlet (DS – RC100 accessory);

TCAETY-TCAESY

Model	a	b	c	d	e	f	g	h	i	l	m	n	o	p
4160 mm	2000	2090	3700	80÷150	180	880	185	150	1670	1670	150	50	1815	300
4180 mm	2030	2090	3700	80÷150	180	880	185	150	1670	1670	150	50	1815	300
4200 mm	2030	2090	3700	80÷150	180	880	185	150	1670	1670	150	50	1815	300
4230 mm	2030	2090	4800	80÷150	180	880	185	150	2220	2220	150	50	1815	300
4260 mm	2030	2090	4800	80÷150	180	880	185	150	2220	2220	150	50	1815	300
4290 mm	2030	2090	4800	80÷150	180	880	185	150	2220	2220	150	50	1815	300
4320 mm	2030	2090	4800	80÷150	180	880	185	150	2220	2220	150	50	1815	300

TCAEQY

Model	a	b	c	d	e	f	g	h	i	l	m	n	o	p
4160 mm	2000	2090	3700	80÷150	180	880	185	150	1670	1670	150	50	1815	300
4180 mm	2000	2090	3700	80÷150	180	880	185	150	1670	1670	150	50	1815	300
4200 mm	2000	2090	3700	80÷150	180	880	185	150	1670	1670	150	50	1815	300
4230 mm	2000	2090	4800	80÷150	180	880	185	150	2220	2220	150	50	1815	300
4260 mm	2000	2090	4800	80÷150	180	880	185	150	2220	2220	150	50	1815	300
4290 mm	2000	2090	4800	80÷150	180	880	185	150	2220	2220	150	50	1815	300

THAETY-THAESY

Model	a	b	c	d	e	f	g	h	i	l	m	n	o	p
4160 mm	2000	2090	3700	80÷150	180	880	185	150	1670	1670	150	50	1815	300
4180 mm	2030	2090	3700	80÷150	180	880	185	150	1670	1670	150	50	1815	300
4200 mm	2030	2090	4800	80÷150	180	880	185	150	2220	2220	150	50	1815	300
4230 mm	2030	2090	4800	80÷150	180	880	185	150	2220	2220	150	50	1815	300
4260 mm	2030	2090	4800	80÷150	180	880	185	150	2220	2220	150	50	1815	300
4290 mm	2030	2090	4800	80÷150	180	880	185	150	2220	2220	150	50	1815	300
4320 mm	2030	2090	4800	80÷150	180	880	185	150	2220	2220	150	50	1815	300

Model	4160	4180	4200	4230	4260	4290	4320
Exchanger inlet/outlet connections	Ø 2 ½"	2 ½"	3"	3"	3"	3"	3"
DS – RC100 inlet/outlet connections	Ø 2 ½"	2 ½"	3"	3"	3"	3"	3"

Clearances and positioning

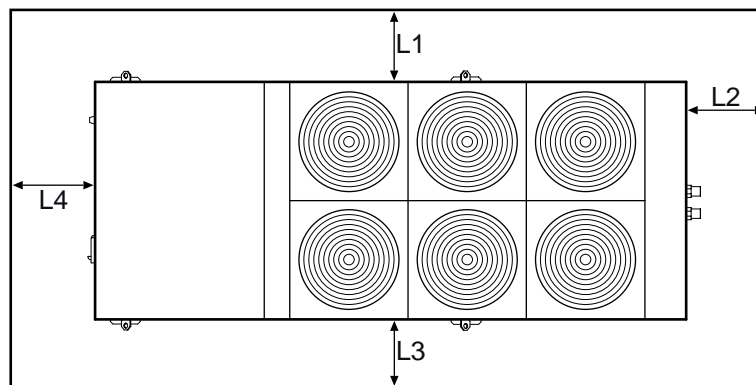

Model	4160	4180	4200	4230	4260	4290	4320
L1 mm	2000	2000	2000	2000	2000	2000	2000
L2 mm	2000	2000	2000	2000	2000	2000	2000
L3 mm	2000	2000	2000	2000	2000	2000	2000
L4 mm	1500	1500	1500	1500	1500	1500	1500

N.B.:

L2 is the minimum distance for the removal of the pump assembly and the relative water buffer tank. If the accessory is not present, the distance can be reduced.

Handling and storage

- The unit should be handled with care to avoid damage to the external structure and to the internal mechanical and electrical components.
- Do not stack the units.
- The temperature limits for storage are -9° to $+45^{\circ}$ C.
- During lifting and handling, make sure that the unit is horizontal at all times.

Installation and connection to the system

- The unit is designed for outdoor installation.
- The unit is fitted with Victaulic type water connections on the air conditioning system water inlet and outlet and on the recovery/ desuperheater inlets and outlets. It is also fitted with carbon steel fittings for welding.
- Segregate the unit if installed in areas accessible to persons under 14 years of age.
- The unit must be positioned to comply with the minimum recommended clearances, bearing in mind the access to water and electrical connections.
- The unit can be equipped with anti-vibration mountings on request (KSA).
- Shut-off valves must be installed that isolate the unit from the rest of the system. Elastic connection joints and system/machine drain taps also need to be fitted.
- A metal mesh filter (with a square mesh measure no more than 0.8 mm), of a suitable size and with suitable pressure drops, must be fitted on unit return pipes.
- However it is installed, the coil inlet air temperature (ambient air) must remain within the set limits.
- The water flow through the heat-exchanger should not fall below a value corresponding to a temperature differential of 8° C (with both compressors on).
- The unit may not be installed on brackets or shelves.
- Correct installation and positioning includes levelling the unit on a surface capable of bearing its weight.
- During long periods of inactivity, it is advisable to drain the water from the system.
- It is possible to avoid draining the water by adding ethylene glycol to the water circuit (see "Use of antifreeze solutions").
- The expansion tank is sized on the basis of the water content of the individual machine. Any additional expansion tank should be sized by the installer on the basis of the system. In the case of models without a pump, the pump must be installed with the pump delivery towards the machine water inlet.

N.B.:

The space over the unit must be free from any possible obstacle. If the unit is completely surrounded by walls, the distances specified are still valid, provided that at least two adjacent walls are not higher than the unit itself.

There must be a minimum gap of at least 3.5 m between the top of the unit and any obstacles above it.

If more than one unit is installed, the minimum distance between the finned coils should be at least 2 m.

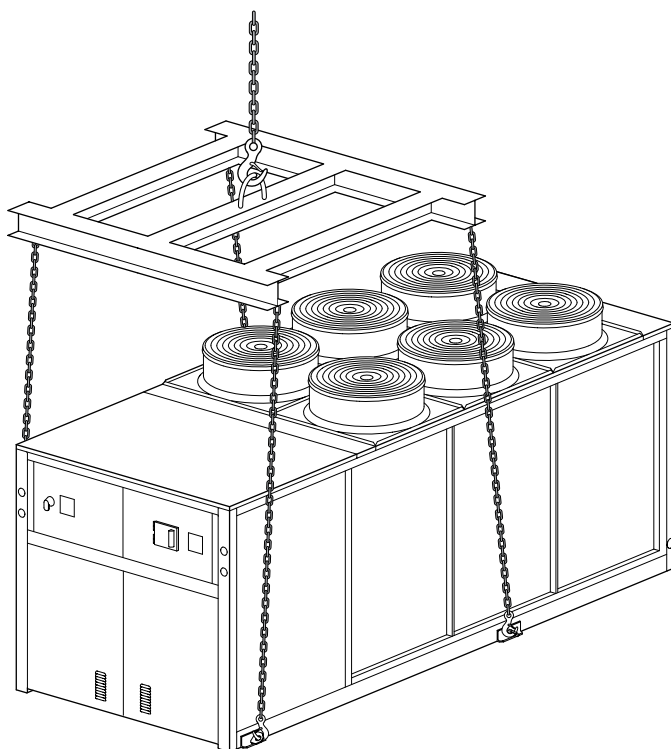

Weight distribution

TCAEBY weights

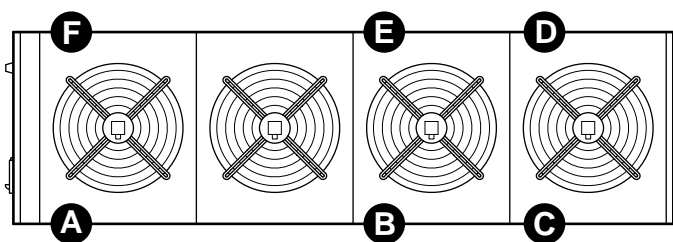

TCAEBY model

Weight	4160	4180	4200	4230	4260	4290	4320
(*) kg	1090	1375	1500	1670	1725	2015	2150
Support (**)							
A kg	265	360	388	448	466	414	437
B kg	-	-	-	216	223	338	362
C kg	281	327	362	170	174	255	276
D kg	281	330	365	175	179	258	279
E kg	-	-	-	219	225	338	362
F kg	263	358	385	442	458	412	434

TCAEBY model with PUMP accessory

Weight	4160	4180	4200	4230	4260	4290	4320
(*) kg	1233	1518	1709	1878	1934	2233	2365
Support (**)							
A kg	278	372	398	449	465	424	444
B kg	-	-	-	274	281	387	410
C kg	340	387	457	215	220	305	328
D kg	337	387	456	219	224	307	330
E kg	-	-	-	277	284	387	410
F kg	278	372	398	444	460	423	443

TCAEBY model with TANK&PUMP accessory

Weight	4230	4260	4290	4320
(*) kg	1981	2033	2329	2459
(**) kg	2749	2804	3102	3235
Support (**)				
A kg	408	420	426	440
B kg	516	524	574	598
C kg	516	524	614	642
D kg	477	484	577	605
E kg	471	480	530	554
F kg	361	372	381	396

(*) Weight of the unit when empty.

(**) Weight of the units including the water present in the tank.

In units with the BCI or SIL accessory, add 100 kg to the total weight.

TCAETY – TCAESY – TCAEQY weights

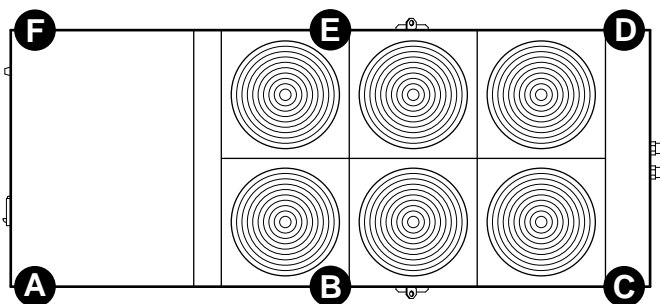

TCAETY-TCAESY-TCAEQY

Weight	4160	4180	4200	4230	4260	4290	4320
(*) kg	1600	2000	2000	2200	2350	2400	2450
Support (**)							
A kg	336	446	456	532	568	586	605
B kg	270	336	335	366	390	398	406
C kg	189	214	202	194	210	208	207
D kg	197	224	215	206	222	220	220
E kg	274	340	340	372	397	405	412
F kg	334	440	452	530	563	583	600

TCAETY-TCAESY-TCAEQY with PUMP accessory

Weight	4160	4180	4200	4230	4260	4290	4320
(*) kg	1750	2250	2250	2400	2550	2600	2700
Support (**)							
A kg	348	460	480	539	574	590	593
B kg	307	400	394	418	442	452	440
C kg	239	308	282	273	289	290	272
D kg	232	290	272	262	279	278	305
E kg	293	370	372	397	422	430	472
F kg	330	422	450	511	544	560	618

TCAETY-TCAESY-TCAEQY with TANK&PUMP accessory

Weight	4160	4180	4200	4230	4260	4290	4320
(*) kg	1834	2234	2332	2479	2627	2724	2769
(**) kg	2600	3000	3100	3250	3400	3500	3550
Support (**)							
A kg	456	565	587	612	646	674	692
B kg	519	585	607	635	660	678	686
C kg	506	532	550	570	585	594	592
D kg	402	430	441	463	480	486	485
E kg	392	458	471	502	527	542	550
F kg	325	430	444	468	502	526	545

(*) Weight of the unit when empty.

(**) Weight of the units including the water present in the tank.

THAETY – THAESY Weights

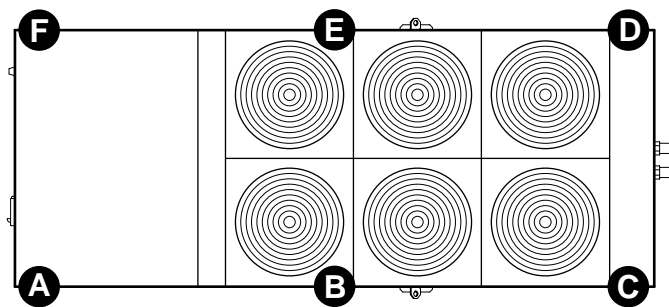

THAETY-THAESY

Weight	4160	4180	4200	4230	4260	4290	4320
(*) kg	1700	2050	2160	2250	2450	2550	2600
Support (**)							
A kg	362	458	544	544	596	628	648
B kg	288	344	374	374	407	423	430
C kg	196	218	200	200	214	216	214
D kg	204	230	122	212	227	230	228
E kg	290	348	380	380	414	430	438
F kg	360	452	540	540	592	623	642

THAETY-THAESY with PUMP accessory

Weight	4160	4180	4200	4230	4260	4290	4320
(*) kg	1850	2200	2450	2450	2650	2750	2800
Support (**)							
A kg	372	470	550	550	602	634	652
B kg	324	382	426	426	460	476	484
C kg	248	268	280	280	294	298	295
D kg	242	264	268	268	284	288	287
E kg	310	368	406	406	438	454	462
F kg	354	448	520	520	572	600	620

THAETY-THAESY with TANK&PUMP accessory

Weight	4160	4180	4200	4230	4260	4290	4320
(*) kg	1934	2284	2532	2579	2727	2824	2869
(**) kg	2700	3050	3300	3350	3500	3600	3650
Support (**)							
A kg	480	578	622	642	676	704	724
B kg	536	593	644	652	678	694	702
C kg	516	535	576	574	590	596	594
D kg	412	434	470	468	484	490	488
E kg	408	466	510	518	542	560	566
F kg	348	444	478	496	530	556	576

(*) Weight of the unit when empty.

(**) Weight of the units including the water present in the tank.

DS - RC100 accessory weights

Weight of the DS and RC100 accessories for models: TCAETY-TCAESY-TCAEQY-THAETY-THAESY

Model	Weight of the DS accessory	
4160	kg	100
4180	kg	100
4200	kg	120
4230	kg	120
4260	kg	120
4290	kg	120
4320	kg	120

Model	Weight of the RC100 accessory	
4160	kg	140
4180	kg	170
4200	kg	180
4230	kg	190
4260	kg	200
4290	kg	210
4320	kg	215

N.B.:

To obtain the total weight of the units with the RC100 and DS accessories, at the weight of the accessory to the weight of the machine.

Water connections

Maximum water circuit content

In order for the units to operate properly, minimum water contents must be guaranteed in the water system. The minimum water content is determined on the basis of the unit's nominal cooling capacity (or heating capacity in the case of heat pumps) (table A *Technical Data*), multiplied by the coefficient expressed in l/kW.

If the minimum content in the system is below the minimum value indicated or calculated, it is advisable to select the TANK&PUMP accessory complete with inertial water buffer tank, and install an additional tank if necessary. However, in process applications it is always advisable to use a water buffer tank or a greater system water content to guarantee higher system thermal inertia.

The minimum circuit water content is 2 l/kW

Example:

THAETY 4320 QT = 342 kW

If the unit envisages control **IDRHSS** compatible with the **AdaptiveFunction Plus** function, the minimum system content must be:

QT (kW) x 2 l/kW = 342 kW x 2 l/kW = 684 l.

Water data

Models		4160	4180	4200	4230	4260	4290	4320
	Safety valve	6	6	6	6	6	6	6
TCAEBY	Exchanger water contents	9	11	16	18	21	23	26
	Tank water content	-	-	-	750	750	750	750
TCAETY-TCAESY-TCAEQY	Exchanger water contents	16	16	18	21	23	26	31
	Tank water content	750	750	750	750	750	750	750
THAESY-THAETY	Exchanger water contents	16	16	18	21	23	26	31
	Tank water content	750	750	750	750	750	750	750

Expansion tank technical data

Installation		P1-P2-DP1-DP2						
		4160	4180	4200	4230	4260	4290	4320
Capacity	l	12	12	12	12	12	12	12
Pre-charging	barg	2	2	2	2	2	2	2
Maximum expansion tank pressure	barg	6	6	6	6	6	6	6

Installation		ASP 1-ASP2-ASDP 1-ASDP2						
		4160	4180	4200	4230	4260	4290	4320
Capacity	l	24	24	24	24	24	24	24
Pre-charging	barg	2	2	2	2	2	2	2
Maximum expansion tank pressure	barg	6	6	6	6	6	6	6

Water circuits

Water circuit standard installation

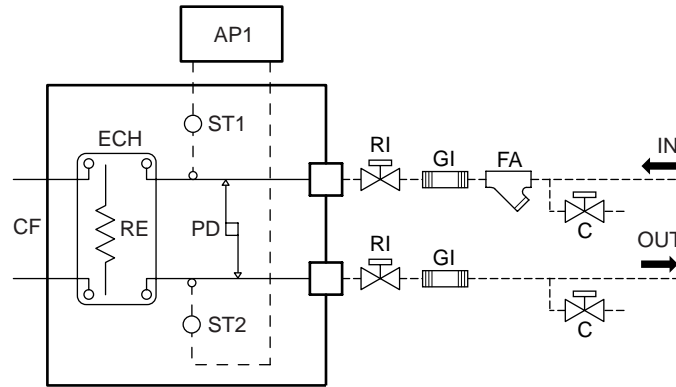

Water circuit P1 - P2 installation

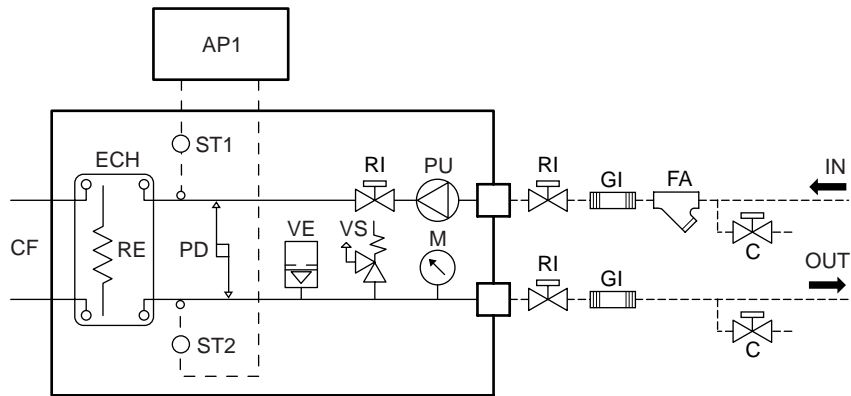

Water circuit ASP1 - ASP2 installation

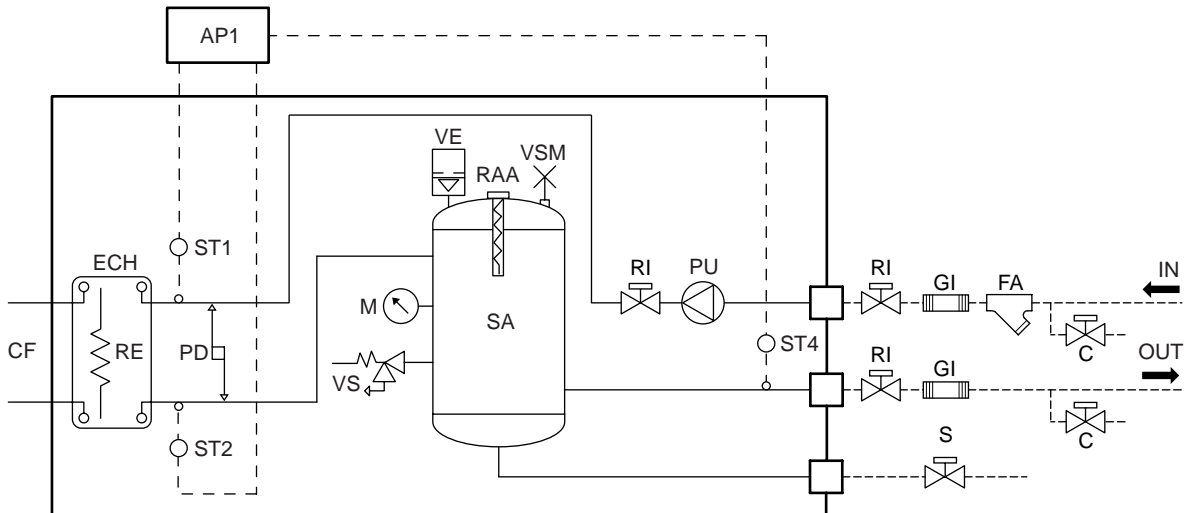

Water circuit DP1 – DP2 installation

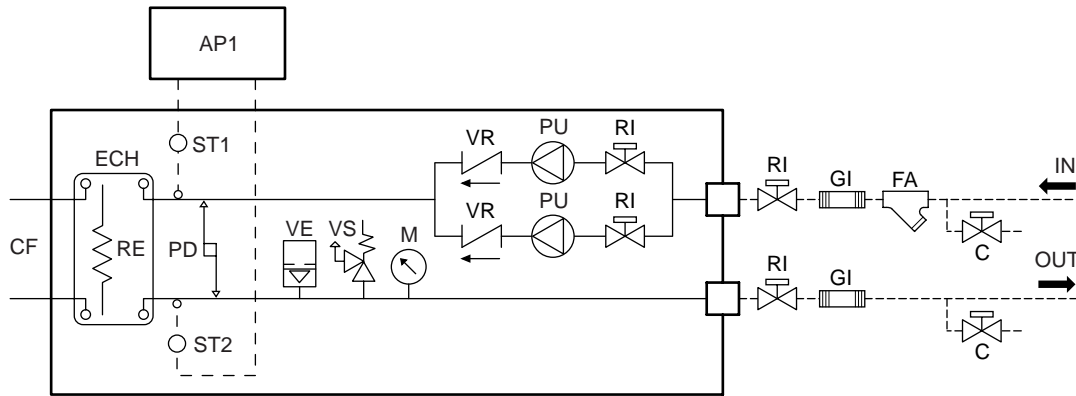

Water circuit ASDP1 – ASDP2 installation

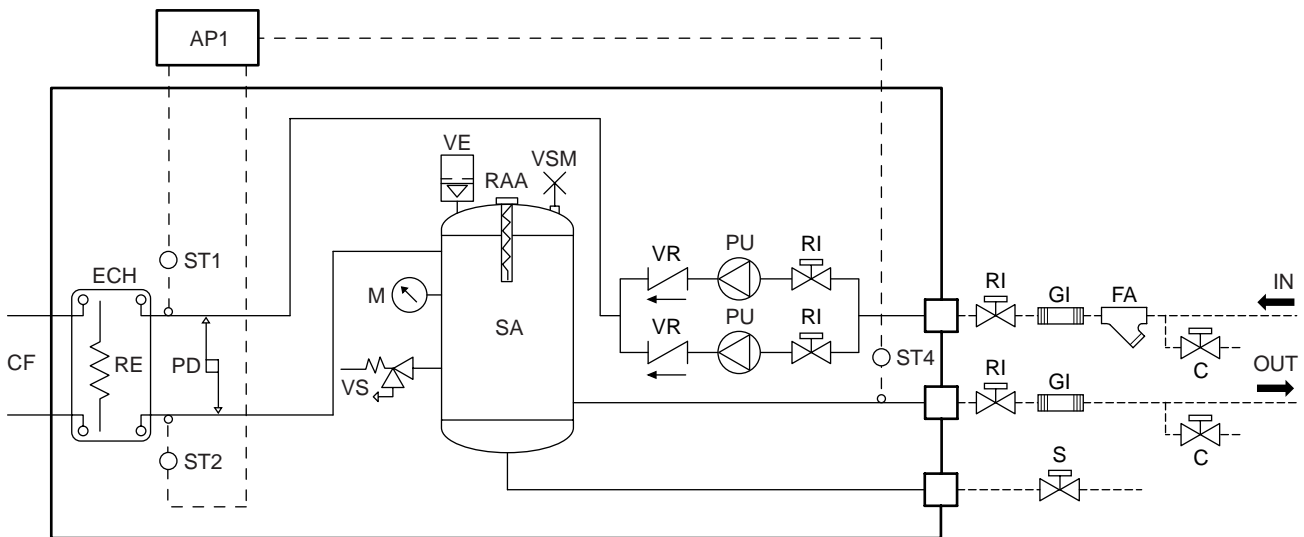

- CF** Refrigerant circuit
- ECH** Plate evaporator
- RE** Evaporator antifreeze electric heater
- PD** Water differential pressure switch
- VSM** Manual bleed valve
- VS** Safety valve
- AP1** Electronic control
- ST1** Primary inlet temperature gauge
- ST2** Primary outlet temperature gauge
- working and antifreeze for Standard and Pump installations
- antifreeze for Tank & Pump installations
- ST4** Water buffer tank outlet temperature gauge (working)
- VE** Expansion tank
- RAA** Water buffer tank electric heater (accessory)
- FA** Mesh filter (installed by the installer)
- SA** Water buffer tank
- M** Pressure gauge
- PU** Pump
- VR** Check valve
- S** Water drain
- C** Charge/drain valve
- RI** Shut-off valve
- GI** Anti-vibration connection

---- Connections to be made by the installer

Electrical connections

- MIQE** Electrical board internal terminal board;
- IG** General isolator;
- L1** Line 1;
- L2** Line 2;
- L3** Line 3;
- N** Neutral;
- PE** Earth terminal;
- KSC** Clock card (accessory);
- KRS485** RS485 serial interface (accessory);
- KUSB** RS485/USB converter (accessory);
- KISI** CAN bus serial interface;
- J19** Connector for KSC accessory installation;
- J20** Connector for KRS485, KFTT10 and KISI accessory installation;
- MEU** External user terminal board;
- KRS232** RS485/RS232 converter (accessory);
- PC** Personal computer;
- SEI** Summer/Winter selector (THAESY-THAETY models) (control with clean contact);
- SCR** Remote control selector (control with clean contact);
- DSP** Dual set-point selector (only available in combination with the EEV accessory);
- KMP1** Pump controls (consent at voltage 230 Vac, maximum load 2A AC1)
- KMP2** Scrolling set point via an analogue signal 4-20 mA (incompatible with the DSP accessory);
- CS** Scrolling set point via an analogue signal 4-20 mA (incompatible with the DSP accessory);
- LBG** General locklight (230 V AC);
- LFC1** Compressor 1 operating light (230V AC);
- LFC2** Compressor 2 operating light (230V AC);
- KMDM** GSM 900-1800 modem kit;
- Connection to be made by the installer;

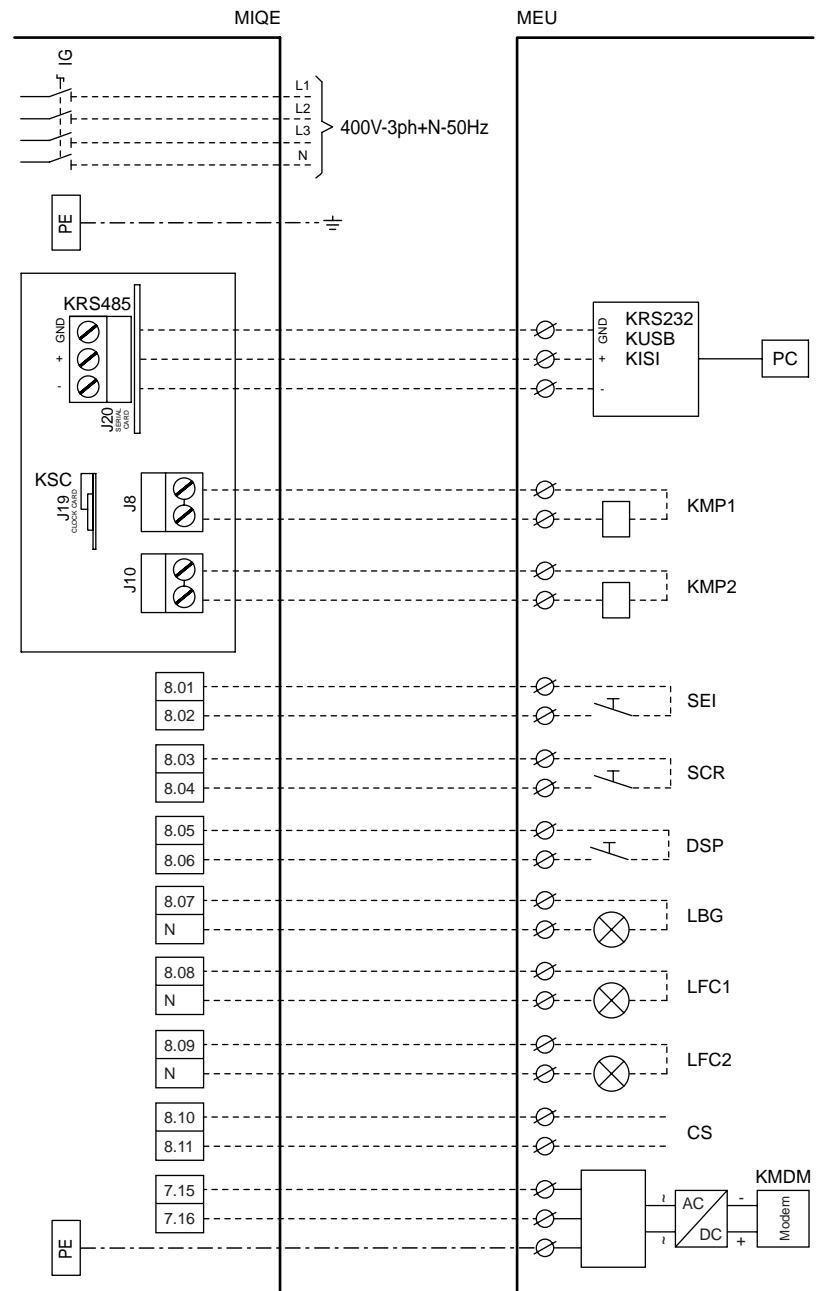

ATTENTION!
The diagrams only show the connections to be made by the installer.

- The electrical panel can be accessed through the front panel of the unit.
- Connections must be made by skilled personnel in compliance with current standards and with the diagrams provided with the machine.
- Always install a general isolator in a protected area near the appliance with a delayed characteristic curve of a suitable capacity and breaking capacity. Make sure the general isolator includes a 3mm minimum opening distance between contacts.
- Earth connection is compulsory by law and safeguards the user while the machine is in use.

N.B.:
Specific terminals are provided for the **CS** and **DSP** accessories.

Cable section		4160	4180	4200	4230	4260	4290	4320
Line section	mm ²	70	70	95	95	120	150	185
PE section	mm ²	35	35	50	50	70	70	95
Remote control section	mm ²	1,5	1,5	1,5	1,5	1,5	1,5	1,5

TCAEY-THAEY 4160÷4320

Y-Pack range

RHOSS S.P.A.

Via Oltre Ferrovia, 32 - 33033 Codroipo (UD) - Italy
tel. +39 0432 911611 - fax +39 0432 911600
rhoss@rhoss.it - www.rhoss.it - www.rhoss.com

IR GROUP S.A.S.

7 rue du Pont à Lunettes - 69390 Vourles - France
tél. +33 (0)4 72318631 - fax +33 (0)4 72318630
exportsales@rhoss.it

RHOSS Deutschland GmbH

Hölzlestraße 23, D-72336 Balingen, OT Engstlatt - Germany
tel. +49 (0)7433 260270 - fax +49 (0)7433 2602720
info@rhoss.de - www.rhoss.de

RHOSS MERCOSUR

Benjamin Constant 576 - 1er Piso C.P. 1214 - Asuncion Paraguay
tel/fax +595 21 493 897 - www.rhossmercosur.com

Sedi commerciali Italia: / Italy branch offices:

Area Nord-Est: 33033 Codroipo (UD) - Via Oltre Ferrovia, 32
tel. +39 0432 911611 - fax +39 0432 911600

Area Nord-Ovest: 20041 Agrate Brianza (MI)
Centro Colleoni - Palazzo Taurus, 1
tel. +39 039 6898394 - fax +39 039 6898395

Area Centro-Sud: 00199 Roma - Viale Somalia, 109
tel. +39 06 8600699-707 - fax +39 06 8600747

Area Sud: 80143 Napoli - Via G. Porzio - Centro Direzionale - Isola G8
tel. +39 081 7879121 - fax +39 081 7879135



RHOSS S.P.A. declines all responsibilities for possible mistakes in the catalogue and reserves the right to alter the features of their products without notice in the interests of continuous improvement.