



CMV (X+/X/ R/ MINI) R410A SERIES 50Hz&60Hz DC INVERTER VRF SYSTEM CAC Catalogue



www.chigo-cac.com



Guangdong Chigo Heating & Ventilation Equipment Co.,Ltd.

Helangsha,Chigo industrial district,lishui,nanhai,foshan,
guangdong,china,P.C:528244

86-757-88781037

86-757-88789825

isc@chigo-cac.com

www.chigo-cac.com



Website



Twitter

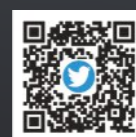

LinkedIn

Note

All the data in this catalogue maybe changed without notice for further improvement on quality and performance.

Provide You With Fresh Air

V.RZQZ



About GCHV

Established in 2011, Guangdong Chigo Heating & Ventilation Equipment Co., Ltd. (GCHV) is a professional central air conditioning equipment manufacture and supply enterprise integrating R&D, testing, manufacturing, marketing, project design, sales and after sales service. GCHV covers an area of 167,000 square meters, with more than 120,000 square meters of plants and 14 modern first class production lines.

GCHV's annual output of central air conditioners exceeds 2 million sets, which including VRF, modular chiller, light commercial air conditioners, air source heat pumps and other products. GCHV's products are in great demand on 100 countries and regions and has accomplished thousands of reference projects worldwide, which enabled it become the top 3 central air conditioner supplier in china.

Chigo commercial air conditioning division established

2004

Honored of "National high-tech enterprises"

2012

Full DC inverter VRF CMV-X series launched

2014

Mechanical and Electrical Installation Level 2 Qualification

2017

GCHV starts operating independently from Chigo Holding

2019

2002

Chigo enter central air conditioning industry

2011

Guangdong Chigo Heating & Ventilation Equipment Co., Ltd. Established

2013

New R&D office building and VRF plant put into operation

2015

Honored of "Provincial engineering research and development center"

2018

2018 Russia World Cup HVAC Supplier Test center certificated by CNAS



Production Capacity

GCHV has 14 advanced production lines and an annual production capacity of over 1.5 million sets.

Introduce lean production management, improve production efficiency. By the use of various robots, AGV system and other equipment, improving the online, offline process, optimizing the logistics distribution technology, improving product quality and production efficiency. Adopts MES (Manufacturing Execution System) system, it helps a lot in tracking production schedule, inventory status, work schedule and other operations management to improve. Product quality and productivity.

Robotic Assembly Arm



Automatic Packing Robot



AGV System



MES System



Quality Superiority



GCHV has established a strict and scientific quality management system with supplier quality assurance, incoming quality control, process quality control and final quality control to ensure the highest quality of the products.

The industry-leading testing center has been certified by CNAS in 2018, With a full range of professional incoming inspection labs, enthalpy difference labs, EMC labs, 27 national accredited labs for testing and verification.

Certification

ISO9001 quality management system, ISO14001 environmental management system, OHSAS18001 occupational health and safety management system, QC080000 electronic and electrical components and products harmful substances process management system certification

Main product certificated by CCC, energy-saving certification, ETL, AHRI, DOE, CE, CB, SASO, ESMA, MEW and others.





Enthalpy Difference Lab



Laboratory Control Room

R&D Strength



200kg Transport Simulation Platform



Professional Engineers

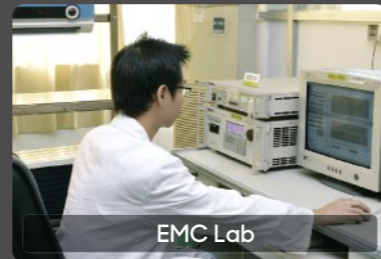

EMC Lab

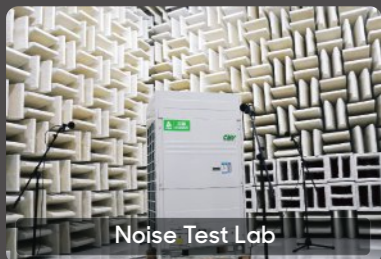

Noise Test Lab



200HP Long-term Running Lab



Modular Chiller Test Lab



Electromagnetic Vibration Lab

The R&D center of GCHV has more than 200 technical engineers. And carry out technology collaboration and joint research with postdoctoral research workstations and Guangdong enterprise workstations, at the same time, introducing senior technical experts from Japan to join GCHV and served as senior technical consultants, GCHV pay great attention in R&D and invest 4.5% of annual income every year to develop new technology, by continuous innovation, GCHV has established a solid development foundation and strength in performance, structure, electronic control, industrial design and other professional aspects.

The test center covers an area of more than 6,000 square meters. It has a series of industry-leading professional laboratories. In 2010, it passed the consistency check of the National Energy Efficiency Label Management Center and obtained certificate, in 2018, the test center obtained CNAS national certification.

Directory

- 01 • Overview
- 02 • CMV-X+/CMV-X
CMV-R
- 31 • Specifications
- 37 • CMV-Mini
- 41 • Specifications
- 42 • Indoor Units
- 63 • Controllers and software
- 68 • Projects

CMV Development History

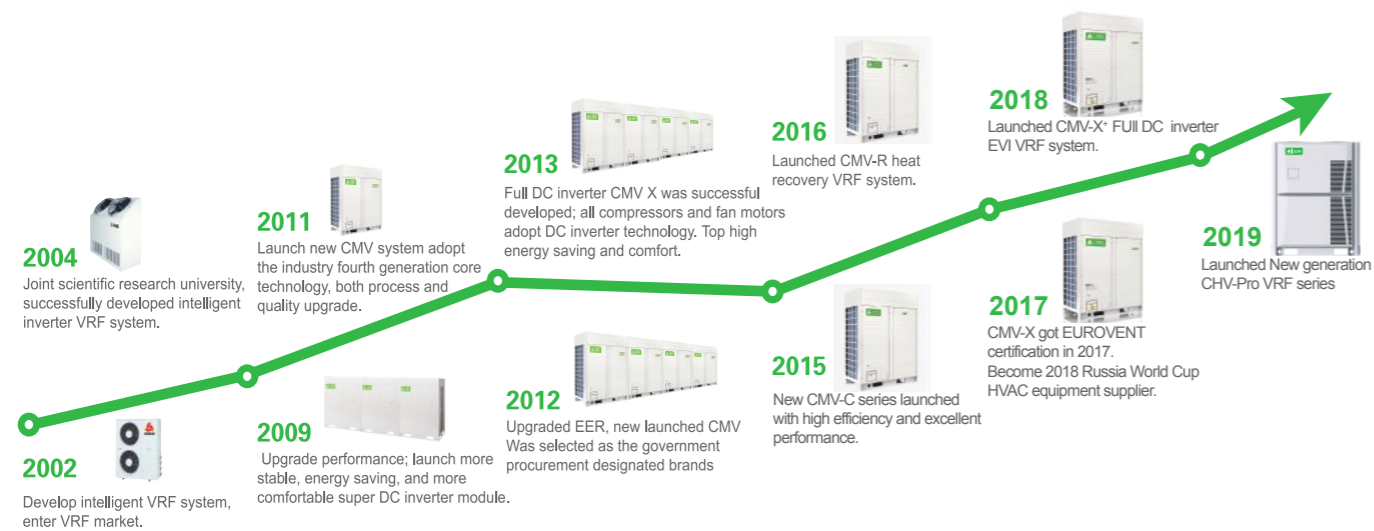

CMV-X+ 380V - 405V/ 50Hz & 60Hz FULL DC INVERTER EVI VRF SYSTEM

Basic Modules

CMV-X+ is CHIGO's latest generation VRF product, all compressors and fan motors are DC brushless type, so it has more excellent energy efficiency.



8/10/12HP



14/16/18/20/22HP

Capacity	8HP	10HP	12HP	14HP	16HP	18HP	20HP	22HP
	25.2kW	28kW	33.5kW	40kW	45kW	50kW	56kW	61.5kW
Compressor	DC	DC	DC	DC	DC	DC+DC	DC+DC	DC+DC
Fan motor	DC	DC	DC	DC+DC	DC+DC	DC+DC	DC+DC	DC+DC

How To Read The Model Name

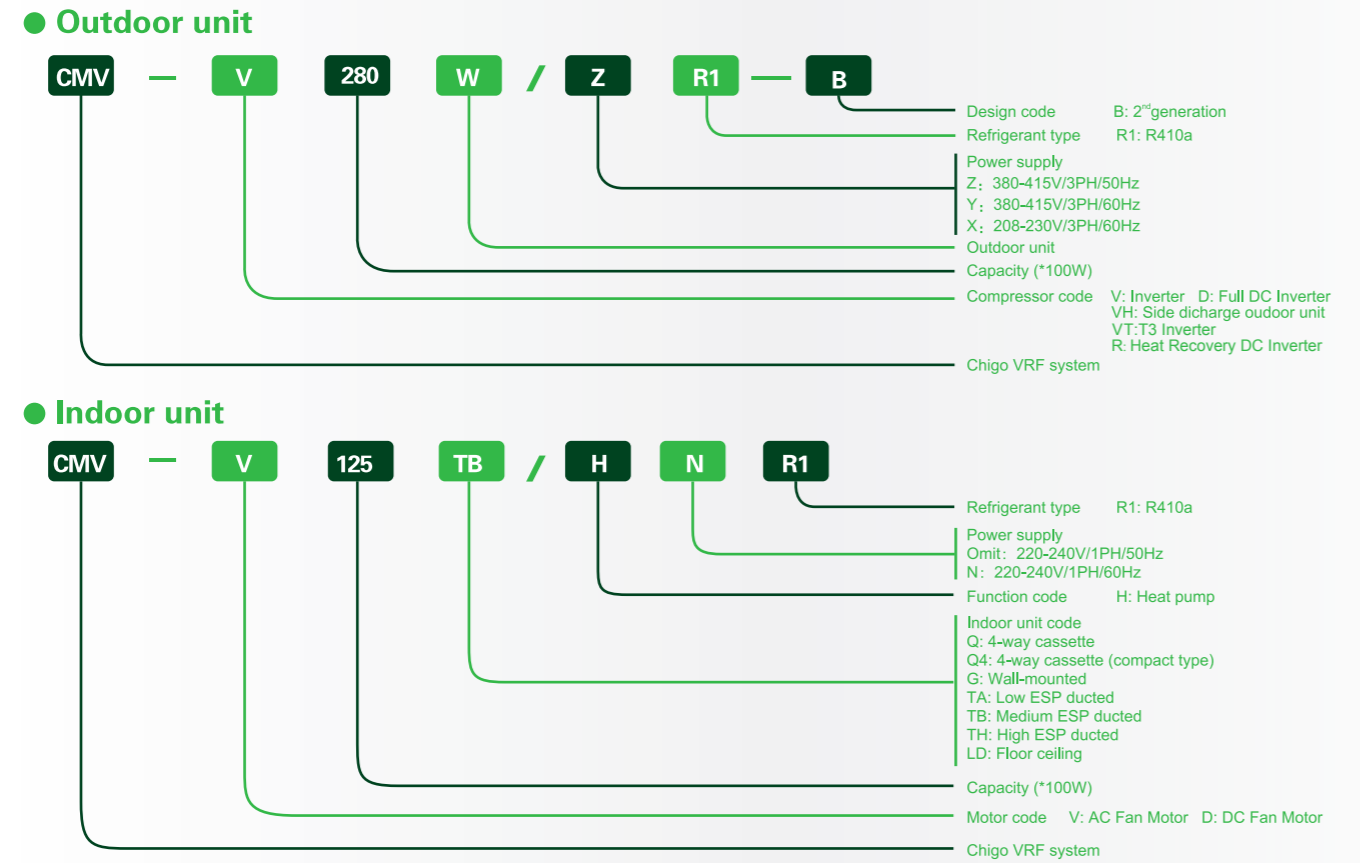

EER & COP

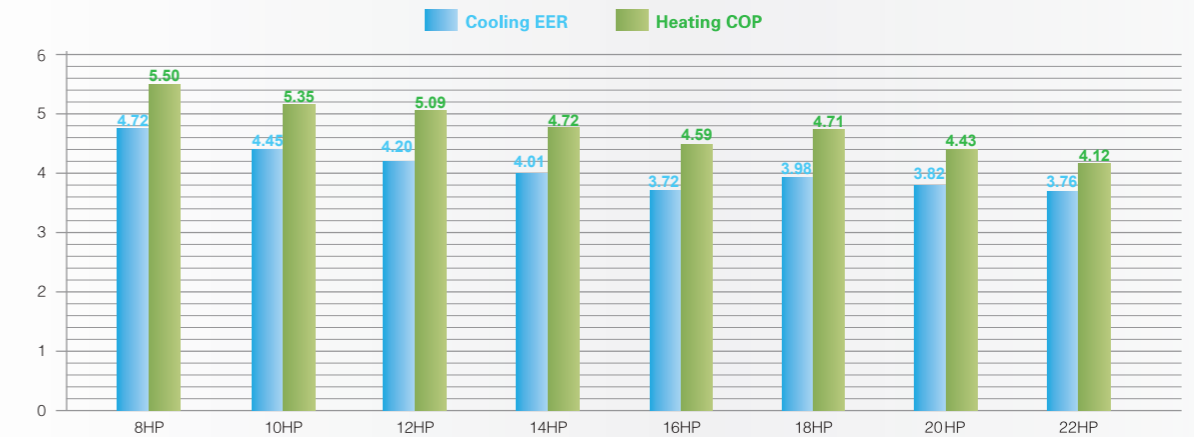

IPLV(C)

IPLV: Integrated Part Load Value (ARI 550/590)
(C): Cooling condition

The Integrated Part Load Value (IPLV) is a performance characteristic developed by the Air-Conditioning, Heating and Refrigeration Institute (AHRI). It is most commonly used to describe the performance of a AC system capable of capacity modulation. Unlike an EER (Energy Efficiency Ratio) or COP (coefficient of performance), which describes the efficiency at full load conditions, the IPLV is derived from the equipment efficiency while operating at various capacities. Since a VRF system does not always run at 100% capacity, the EER or COP is not an ideal representation of the typical equipment performance. The IPLV is a very important value to consider since it can affect energy usage and operating costs throughout the lifetime of the equipment.

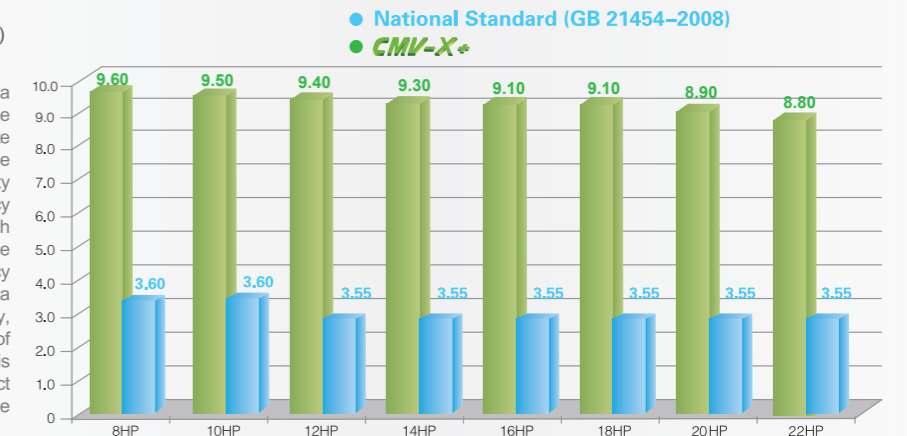

Combination Table

HP	Model	Cooling Capacity(KW)	Cooling Capacity									Max. Connected Indoor Unit Quantity
			8HP	10HP	12HP	14HP	16HP	18HP	20HP	22HP		
8	CMV-D252W/ZR1-B	25.2	●									13
10	CMV-D280W/ZR1-B	28		●								16
12	CMV-D335W/ZR1-B	33.5			●							16
14	CMV-D400W/ZR1-B	40				●						20
16	CMV-D450W/ZR1-B	45					●					20
18	CMV-D500W/ZR1-B	50						●				20
20	CMV-D560W/ZR1-B	56							●			24
22	CMV-D615W/ZR1-B	61.5								●		24
24	CMV-D670W/ZR1-B	67			●●							28
26	CMV-D730W/ZR1-B	73		●				●				28
28	CMV-D780W/ZR1-B	78		●					●			28
30	CMV-D835W/ZR1-B	83.5			●					●		32
32	CMV-D895W/ZR1-B	89.5		●							●	32
34	CMV-D950W/ZR1-B	95			●						●	36
36	CMV-D1010W/ZR1-B	101					●			●		36
38	CMV-D1065W/ZR1-B	106.5					●				●	36
40	CMV-D1115W/ZR1-B	111.5						●			●	42
42	CMV-D1175W/ZR1-B	117.5							●		●	42
44	CMV-D1230W/ZR1-B	123								●	●	42
46	CMV-D1285W/ZR1-B	128.5			●●						●	48
48	CMV-D1345W/ZR1-B	134.5		●			●				●	48
50	CMV-D1400W/ZR1-B	140			●		●				●	54
52	CMV-D1450W/ZR1-B	145			●			●			●	54
54	CMV-D1510W/ZR1-B	151		●						●●	●	54
56	CMV-D1565W/ZR1-B	156.5			●					●●	●	58
58	CMV-D1630W/ZR1-B	163				●				●●	●	58
60	CMV-D1680W/ZR1-B	168					●			●●	●	58
62	CMV-D1730W/ZR1-B	173						●		●●	●	64
64	CMV-D1790W/ZR1-B	179							●	●●	●	64
66	CMV-D1845W/ZR1-B	184.5								●●●	●	64
68	CMV-D1900W/ZR1-B	190			●●					●●	●	64
70	CMV-D1960W/ZR1-B	196		●			●			●●	●	64
72	CMV-D2015W/ZR1-B	201.5			●		●			●●	●	64
74	CMV-D2065W/ZR1-B	206.5			●			●		●●	●	64
76	CMV-D2125W/ZR1-B	212.5		●						●●●	●	64
78	CMV-D2180W/ZR1-B	218			●					●●●	●	64
80	CMV-D2245W/ZR1-B	224.5				●				●●●	●	64
82	CMV-D2295W/ZR1-B	229.5					●			●●●	●	64
84	CMV-D2345W/ZR1-B	234.5						●		●●●	●	64
86	CMV-D2405W/ZR1-B	240.5							●	●●●	●	64
88	CMV-D2460W/ZR1-B	246								●●●●	●	64

Long Piping & Height Difference

- The total pipe length: 1000m
- The longest pipe :
 - Actual length 190m
 - Equivalent length 220m
- Equivalent length from first indoor distributor to last indoor unit: 90m
- Height difference between indoor and outdoor unit:
 - Outdoor unit above <90m
 - Outdoor unit below <110m
- Height difference between indoor units: 30m

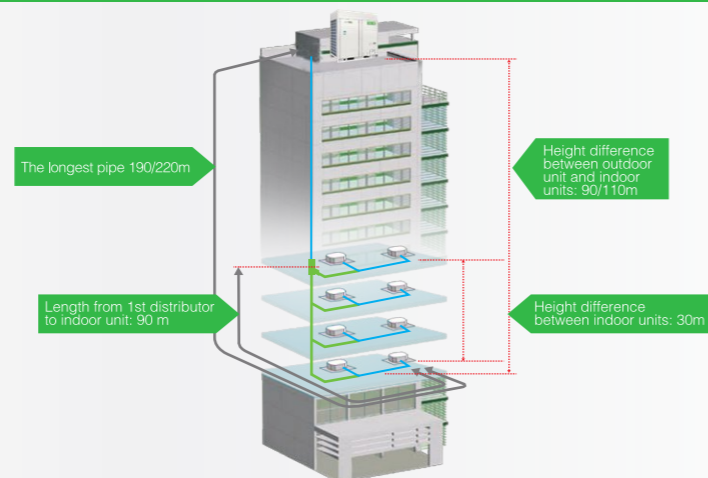

What Is EVI VRF System

Enhanced Vapor Injection Compressor

The Enhanced vapor injection compressor adopts two-stage throttling intermediate injection technology, which uses a flash vaporizer for gas-liquid separation to achieve the effect of increasing the enthalpy. It is cooled by vapor injection mixing at medium and low pressures while compressing, and then compressed normally at high pressure to increase the displacement of the compressor and achieve great heating performance improvement in a low temperature environment. This compressor could heating at -30°C, and Heating capacity increased by nearly 20%-50% at -15°C.

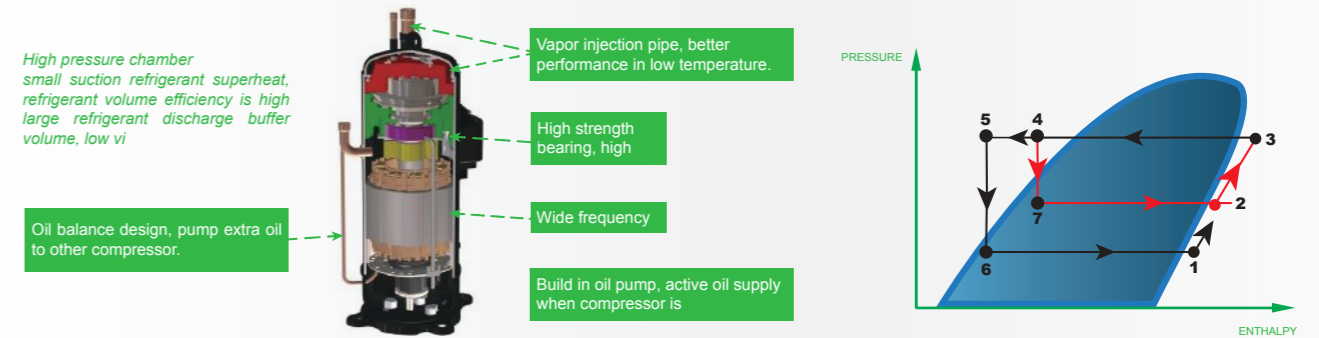

Theory of Enhanced Vapor Injection

With the help of high-efficiency heat exchanger, on the one hand, the refrigerant in main circulation supercooling before throttling to increase the enthalpy difference, on the other hand, the low temperature and low pressure refrigerant which has been depressurized by the electronic expansion valve in the auxiliary circuit is appropriately preheated to achieve a suitable medium pressure, provide to the compressor for secondary compression.

When the outdoor temperature is very low, the heat exchange capacity of the outdoor unit is reduced, so the normal air return volume of the compressor is reduced, which lead to the reduction of compressor capacity, and the best effect cannot be exerted. However, the refrigerant gas is replenished through the intermediate pressure air return injection port, increase the displacement of the compressor, and the refrigerant circulating amount of the indoor unit heat exchanger is increased to improve the heating capacity. Therefore, it is more suitable for cold regions.

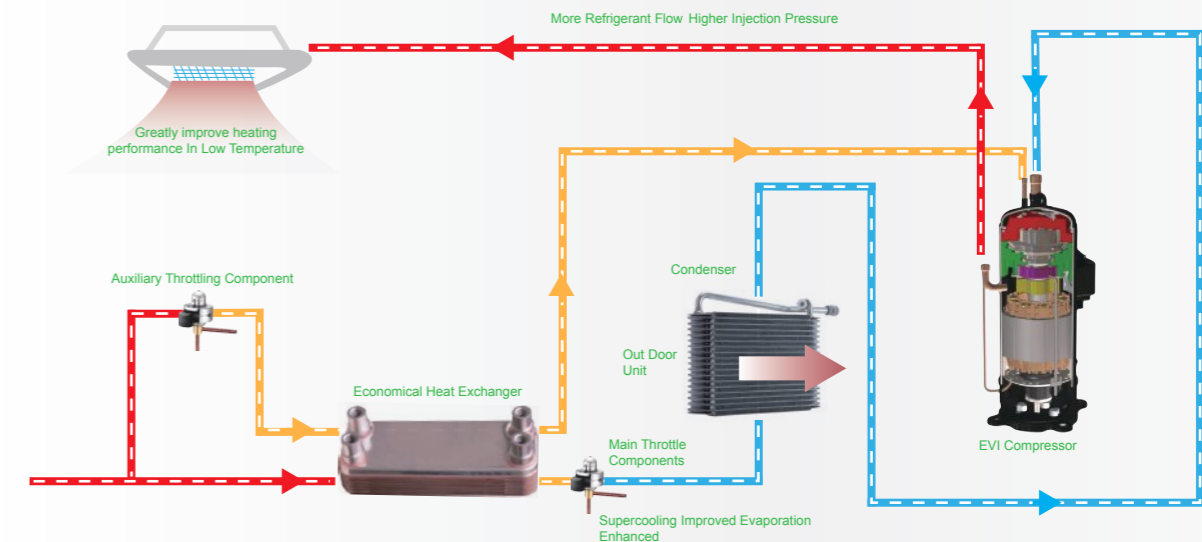

Wide Operation Range

- Due to global warming is getting worse, cooling operating temperature is increased to 55°C.

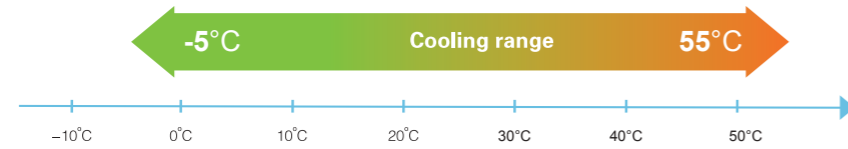

- Heating operating temperature is down to -30°C. In the cold winter, CMV system can heat the room continuously.

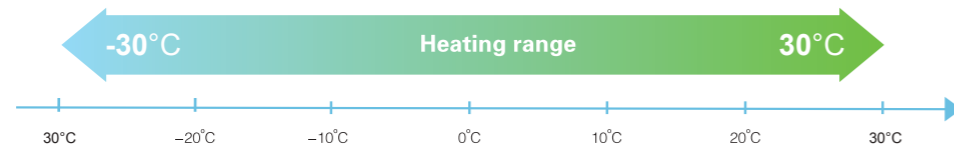

Power Saving Mode

- In case of power shortage, CMV-X+ can run as power saving mode to ease power grid pressure.

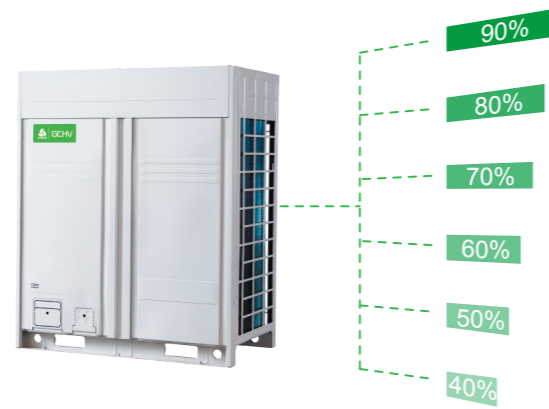

Refrigerant Cooling Design

- In CMV-X+, we use refrigerant to cool down inverter modular board, to keep unit in a safety condition.

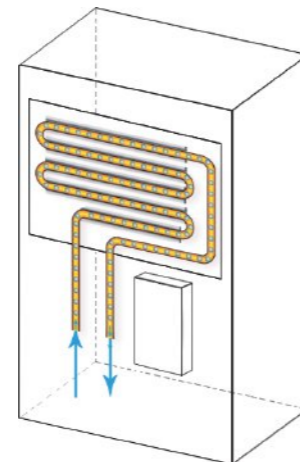

Refrigerant Status Checking

- CMV-X+ is building in smart auto checking logic, which can give suggestion about refrigerant status.

Different code means different refrigerant status:

- 0: Normal
- 1: Slightly excess
- 2: Overmuch
- 11: Slightly insufficient
- 12: Insufficient
- 13: Extremely insufficient

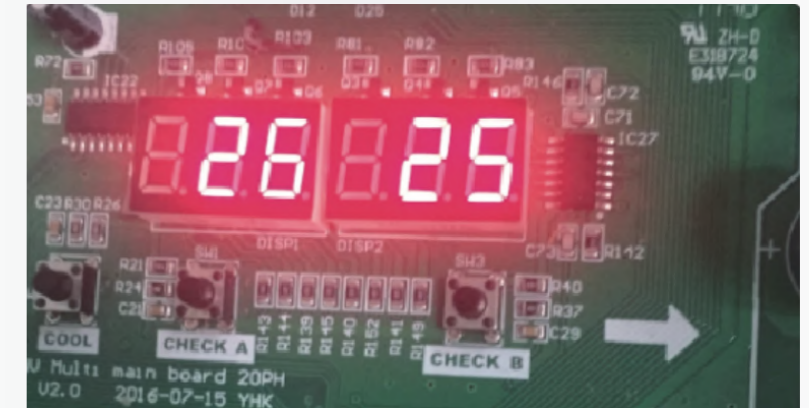

Refrigerant Auto Charging (Customized Function)

- CMV-X+ can customize with auto charging refrigerant function, we will add SV10 valve in gas pipe, and outdoor unit will control SV10 to charge refrigerant or not.

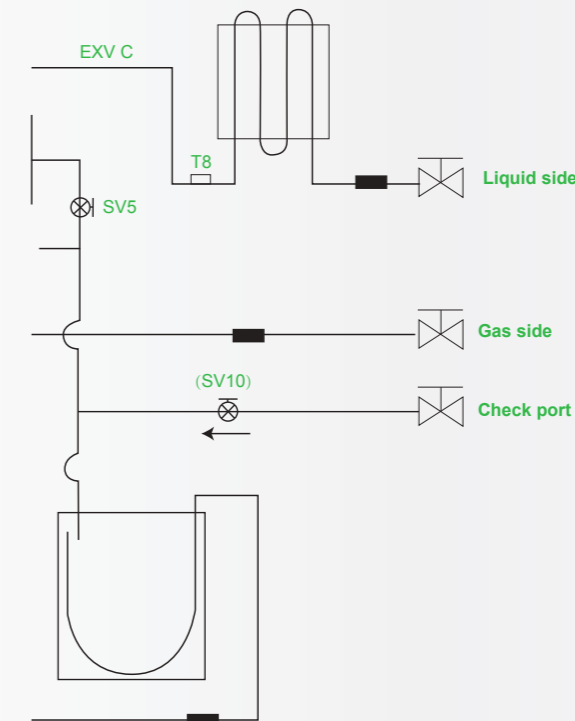

Basic Modules

CMV-X is CHIGO's latest generation VRF product, all compressors and fan motors are DC brushless type, so it has more excellent energy efficiency.



8/10HP



12/14/16HP



18/20HP

Capacity	8HP	10HP	12HP	14HP	16HP	18HP	20HP
		25.2kW	28kW	33.5kW	40kW	45kW	50kW
Compressor	DC	DC	DC	DC+DC	DC+DC	DC+DC	DC+DC
Fan motor	DC	DC	DC+DC	DC+DC	DC+DC	DC+DC	DC+DC

EER & COP

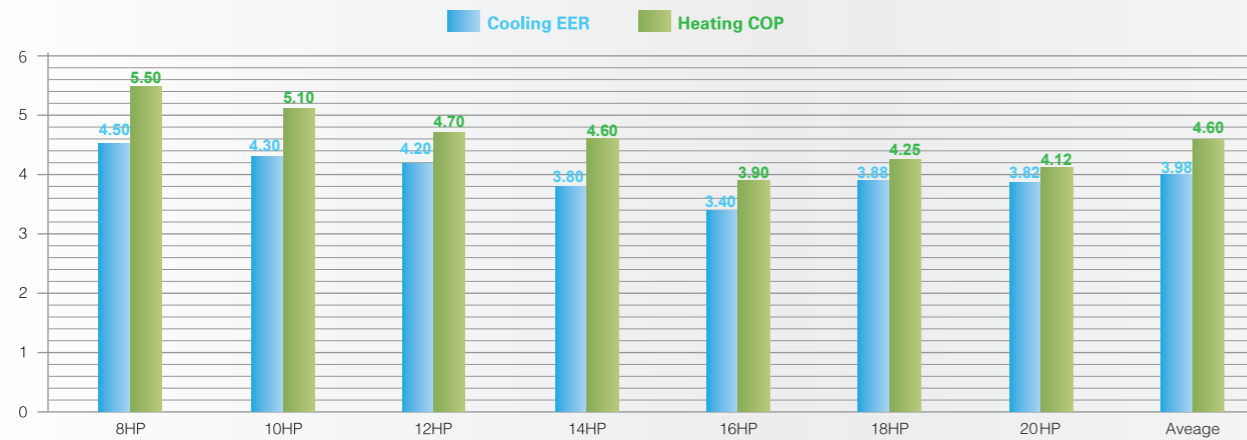

IPLV(C)

IPLV: Integrated Part Load Value (ARI 550/590)
(C): Cooling condition

The Integrated Part Load Value (IPLV) is a performance characteristic developed by the Air-Conditioning, Heating and Refrigeration Institute (AHRI). It is most commonly used to describe the performance of a AC system capable of capacity modulation. Unlike an EER (Energy Efficiency Ratio) or COP (coefficient of performance), which describes the efficiency at full load conditions, the IPLV is derived from the equipment efficiency while operating at various capacities. Since a VRF system does not always run at 100% capacity, the EER or COP is not an ideal representation of the typical equipment performance. The IPLV is a very important value to consider since it can affect energy usage and operating costs throughout the lifetime of the equipment.

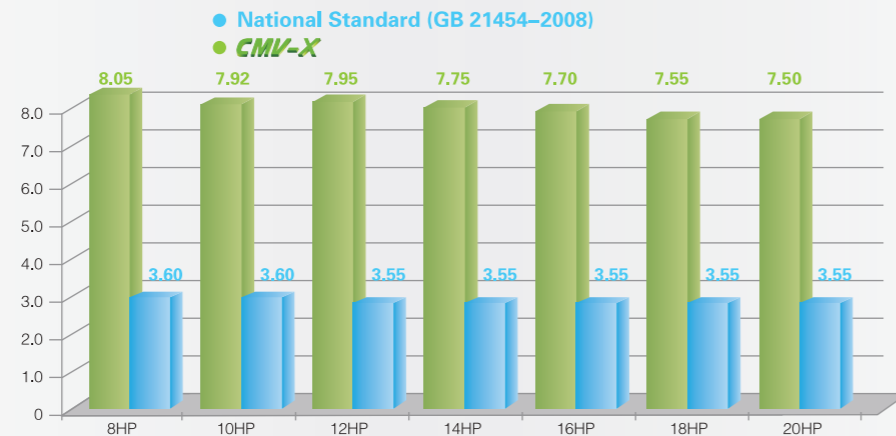

Combination Table

HP	Cooling Capacity(KW)	Cooling Capacity								Max. Connected Indoor Unit Quantity
		8HP	10HP	12HP	14HP	16HP	18HP	20HP		
8	25.2	●							13	
10	28		●						16	
12	33.5			●					16	
14	40				●				20	
16	45					●			20	
18	50						●		20	
20	56							●	24	
22	61.5		●	●					24	
24	68			●●					28	
26	73		●			●			28	
28	78		●				●		28	
30	84		●					●	32	
32	89.5			●				●	32	
34	95					●	●	●	36	
36	101					●		●	36	
38	106						●	●	36	
40	112							●●	42	
42	117.5		●	●				●	42	
44	123			●●				●	42	
46	129		●			●		●	48	
48	134		●				●	●	48	
50	140		●					●●	54	
52	145.5			●				●●	54	
54	152				●			●●	54	
56	157					●		●●	58	
58	162						●	●●	58	
60	168						●●	●●	58	
62	175.2	●					●	●●	64	
64	179			●●				●●	64	
66	185		●			●		●●	64	
68	190		●				●	●●	64	
70	196		●					●●●	64	
72	201.5			●				●●●	64	
74	207					●	●	●●	64	
76	213					●		●●●	64	
78	218						●	●●●	64	
80	224							●●●●	64	

Long Piping & Height Difference

- The total pipe length: 1000m
- The longest pipe :
 - Actual length 190m
 - Equivalent length 220m
- Equivalent length from first indoor distributor to last indoor unit: 90m
- Height difference between indoor and outdoor unit:
 - Outdoor unit above <90m
 - Outdoor unit below <110m
- Height difference between indoor units: 30m

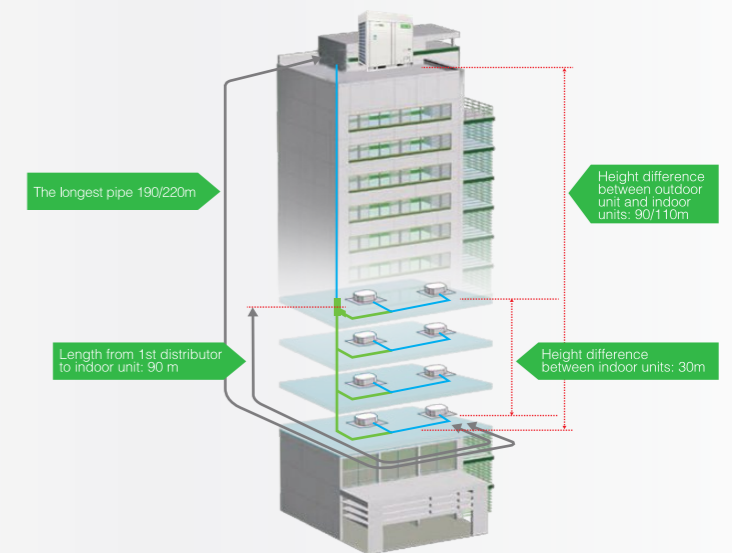

CMV Development History

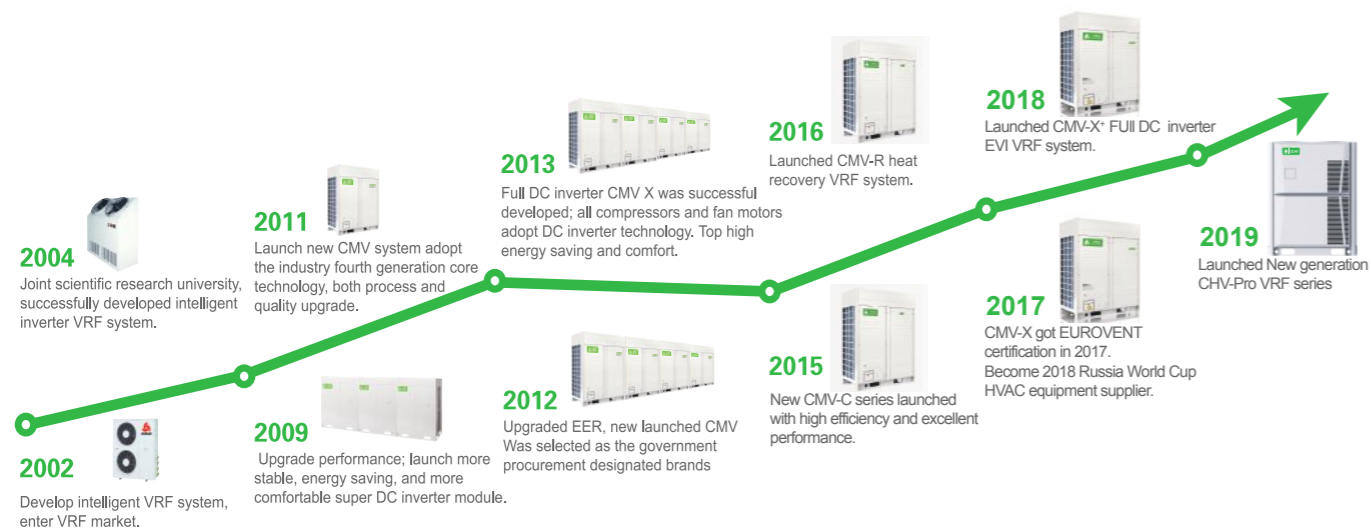

How To Read The Model Name

Outdoor unit

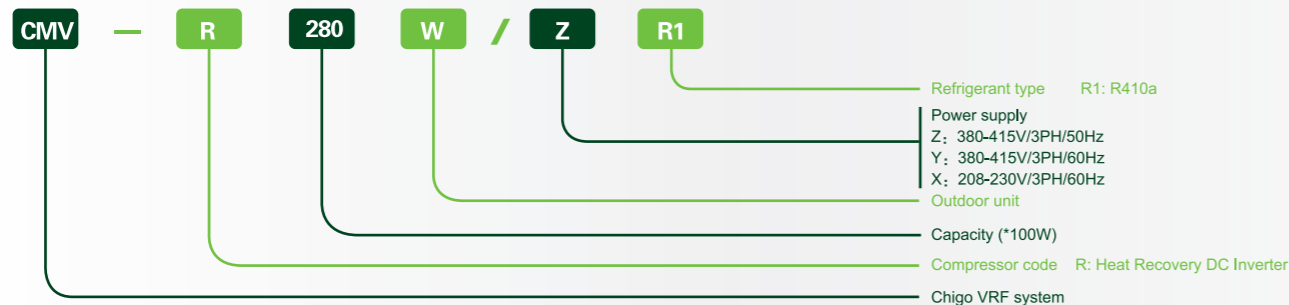

Indoor unit

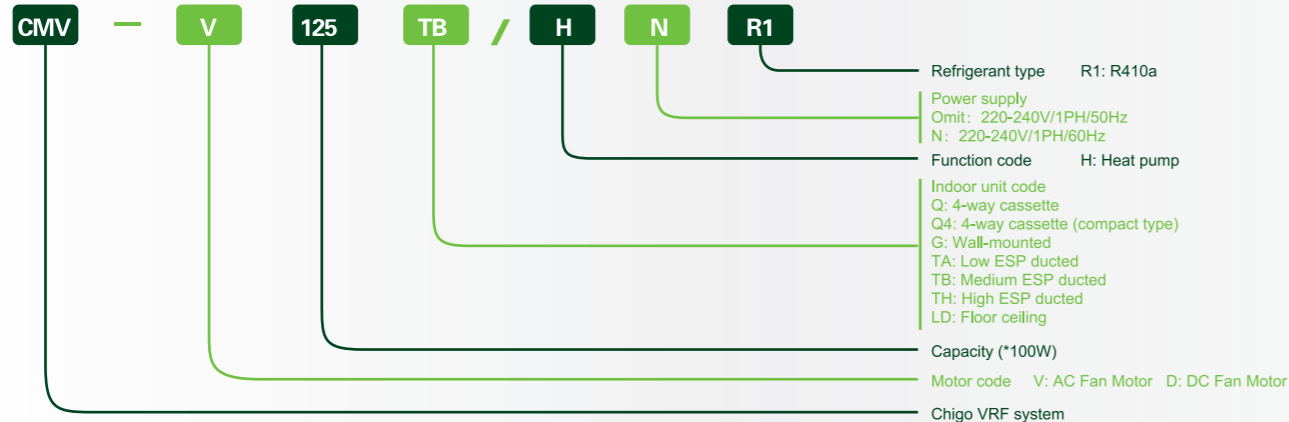

**380V-405V/50Hz&60Hz
HEAT RECOVERY SYSTEM**

Basic Modules

CMV-R is heat recovery VRF product with all DC inverter compressors and DC brushless fan motors. It achieve high operating energy efficiency by drawing heat from the room to be cooled and transferring it as energy for rooms that are to be heated.

Energy saving of the operating systems has been greatly improved as heating and cooling modes can be operated at the same time on one VRF system.



8/10/12/14/16HP

Capacity	8HP	10HP	12HP	14HP	16HP
	25.2kW	28kW	33.5kW	40kW	45kW
Compressor	DC	DC	DC	DC+DC	DC+DC
Fan motor	DC+DC	DC+DC	DC+DC	DC+DC	DC+DC
Power type	208-230V			380-415V	
50Hz / 3phase				●	
60Hz / 3phase				●	

EER & COP

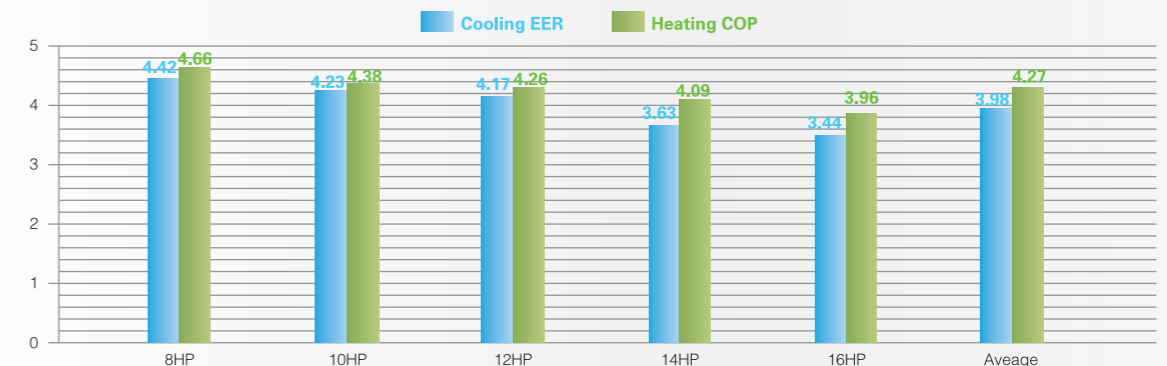

Combination Table

Cooling Capacity		Cooling Capacity(KW)					Max. Connected Indoor Unit Quantity
HP	KW	8HP	10HP	12HP	14HP	16HP	
8	25.2	●					13
10	28		●				16
12	33.5			●			16
14	40				●		16
16	45					●	20
18	53.2	●	●				20
20	56		●●				24
22	61.5		●	●			24
24	68		●		●		28
26	73		●			●	28
28	80				●●		28
30	85				●	●	32
32	90					●●	32
34	96		●●		●		36
36	101		●●			●	36
38	106.5		●	●		●	36
40	113		●			●	42
42	120				●●●		42
44	125				●●	●	42
46	130				●	●●	48
48	135					●●●	48
50	143.2	●	●			●●	54
52	146		●●			●●	54
54	151.5		●	●		●●	54
56	158		●		●	●●	58
58	165				●●●	●	58
60	170				●●	●●	58
62	175				●	●●●	64
64	180					●●●●	64

What Is Heat Recovery VRF system

Simultaneous Cooling And Heating Operation

CMV-R is 3-pipe heat recovery VRF product with all DC inverter compressors and DC brushless fan motors. It offers simultaneous cooling and heating operation in one system.

CMV-R achieves high operating energy efficiency by drawing heat from the room to be cooled and transferring it as energy for rooms that are to be heated.

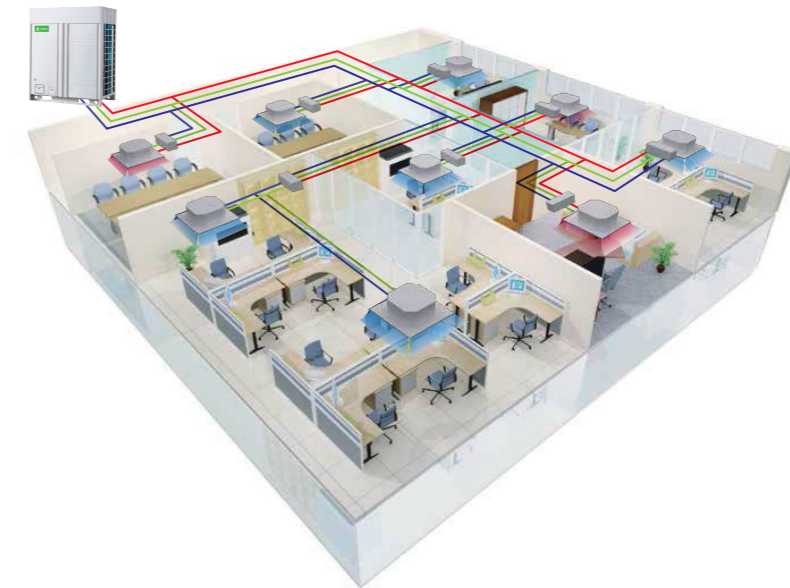

Long Piping & Height Difference

- The total pipe length: 1000m
- The longest pipe :
 - Actual length 175m
 - Equivalent length 200m
- Equivalent length from first indoor distributor to last indoor unit: 65m
- Height difference between indoor and outdoor unit:
 - Outdoor unit above <70m
 - Outdoor unit below <110m
- Height difference between indoor units: 30m

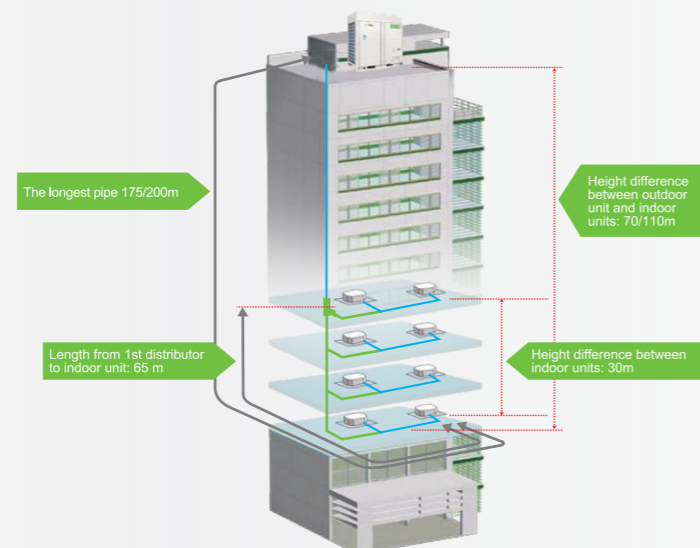

Heat Recovery, More Efficiency

Simultaneous heating and cooling in different zones, more energy saving by heat recovery from one space to another which saves up to 50% in costs compared with a conventional heat pump system.

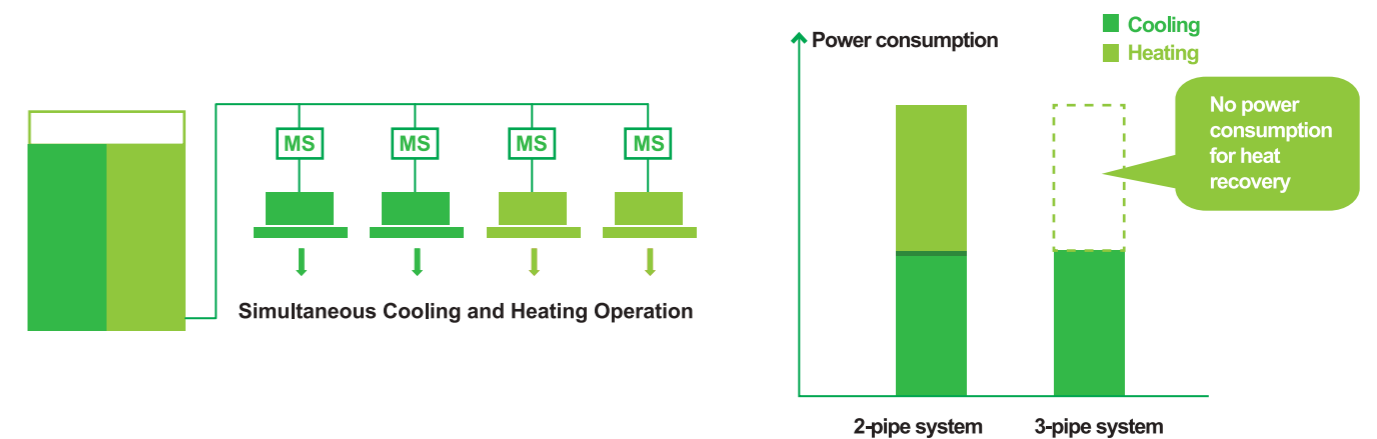

CMV-mini SMALL CAPACITY FULL DC INVERTER VRF UNIT

10 Models



Capacity	8kW	10kW	12.5kW	14kW	16kW	18kW	22.4kW	26kW	28kW	33.5kW
Compressor	DC	DC	DC	DC	DC	DC	DC	DC	DC	DC
Fan motor	DC	DC	DC+DC	DC+DC	DC+DC	DC+DC	DC+DC	DC+DC	DC+DC	DC+DC

Power type	208~230V/1PH	380~415V/3PH
50HZ	8/10/12.5/14/16kW	12.5/14/16/18/22.4/26/28/33.5kW
60HZ	8/10/12.5/14/16kW	12.5/14/16/18/22.4/26/28/33.5kW

EER & COP

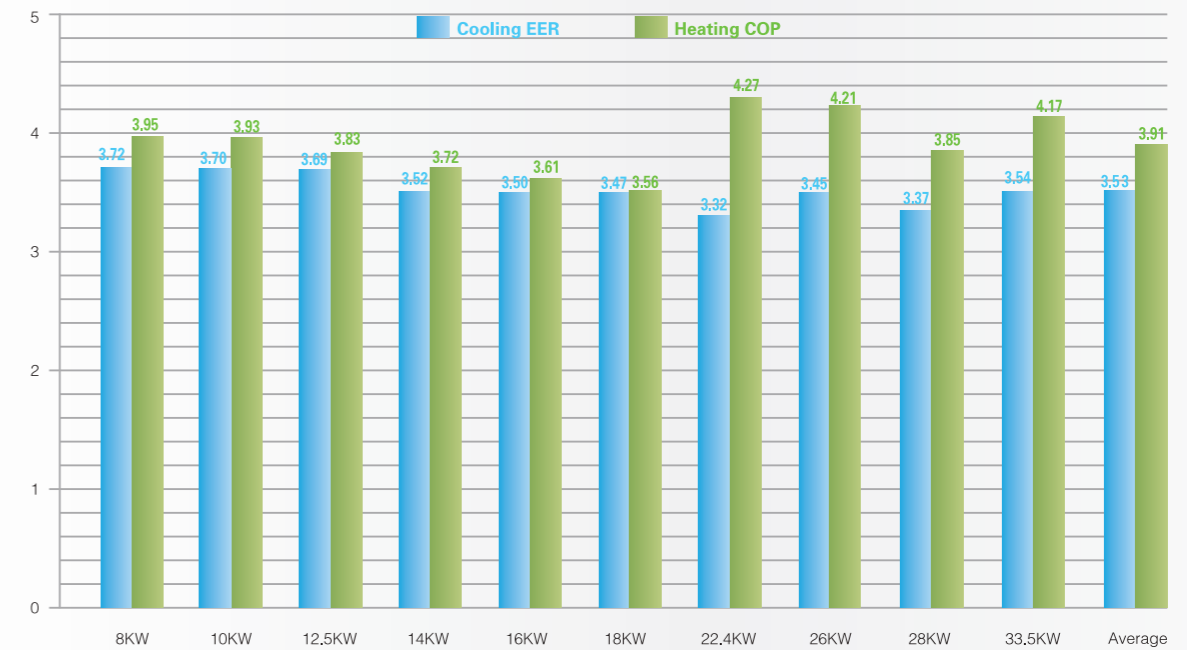

Long Piping & Height Difference

- The total pipe length: 100m (8-18kW), 120m (22.4-33.5kW)
- The longest pipe :
 - Actual length 60m
 - Equivalent length 70m
- Equivalent length from first indoor distributor to last indoor unit: 20m
- Height difference between indoor and outdoor unit:
 - Outdoor unit above <30m
 - Outdoor unit below <20m
- Height difference between indoor units: 8m

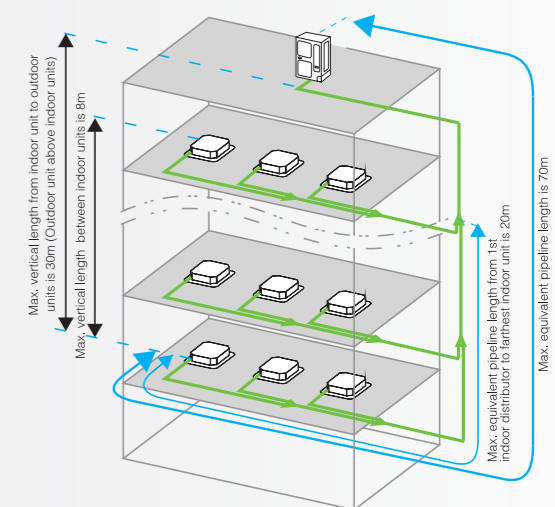

CMV-X+ CMV-X CMV-R



- High Efficiency
- Benefits For Users
- Benefits For Installers

Advantages

High Efficiency

Low carbon life advocate

Chigo CAC always focus on low-carbon energy-saving products development, and spare no effort for technological research and development, to become a practitioner and advocate of low-carbon technology!

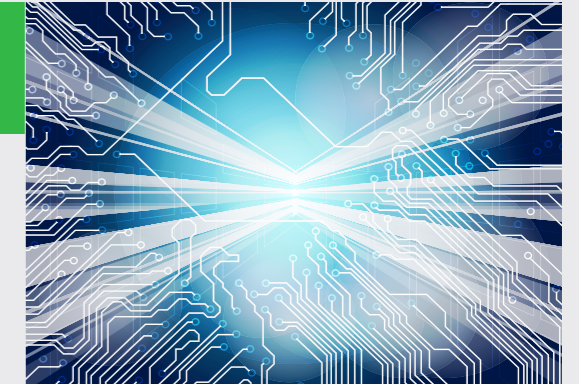

Core Technologies Make High Efficiency

CMV-X+	CMV-X	CMV-R
●	●	●

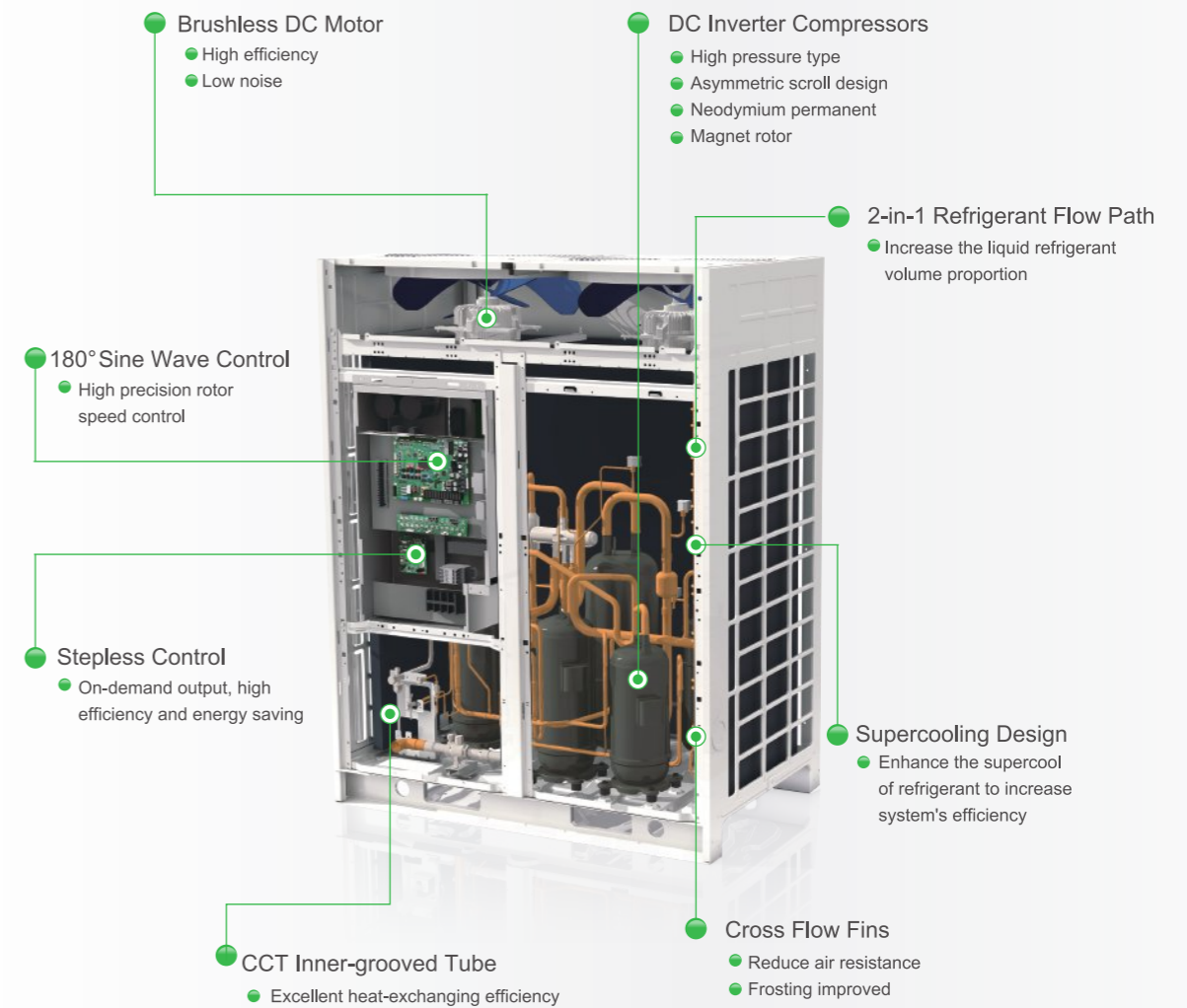

High Efficiency DC Inverter Compressor

CMV-X+	CMV-X	CMV-R
●	●	●

- From Hitachi, famous inverter compressor manufacturer.
- R410a ECO friendly refrigerant.
- Small torque fluctuation, low vibration and quiet operation.
- High efficiency due to its patent internal structure design.
- Internal oil circulation structure.
- High Reliability.
- Wide rotation speed range.
- Neodymium permanent magnet rotor, has powerful magnetic force, large torque and high efficiency.
- Concentrated winding, improving low frequency efficiency.



- High pressure chamber
 - Has small suction superheat and high refrigerant volume efficiency
 - Has large refrigerant discharge buffer volume, Low vibration and noise

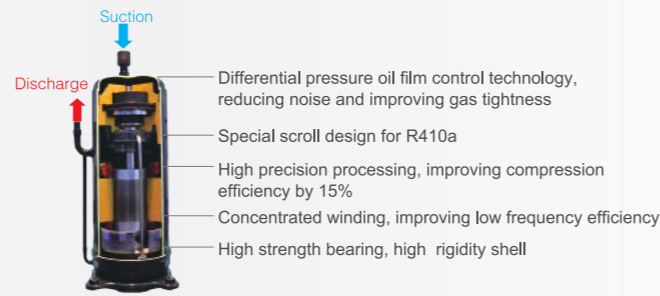

Neodymium permanent magnet rotor

Powerful magnetic force, large force moment and high efficiency.

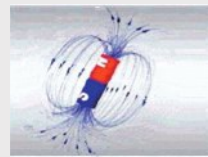

Ferrite magnet

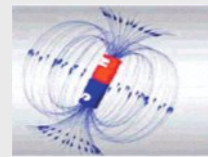

Neodymium permanent magnet

Concentrated winding

Magnetic efficiency is 12% higher than distributed winding

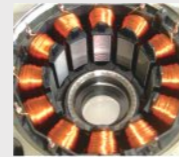

Concentrated winding

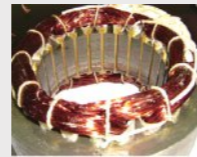

Distributed winding

High Efficiency DC Motor

CMV-X+	CMV-X	CMV-R
●	●	●

- High efficiency DC fan motor is from well-known brand.
- Low noise and high efficiency because of high-density wire winding engineering.
- Brushless with built-in sensor.



DC fan motor

Stepless Control

CMV-X+	CMV-X	CMV-R
●	●	●

DC fan motor can be stepless controlled by outdoor PCB according to system's operating pressure. And it is able to reduce the energy consumption and maintain the system in the best performance.

Load-Revolution curve

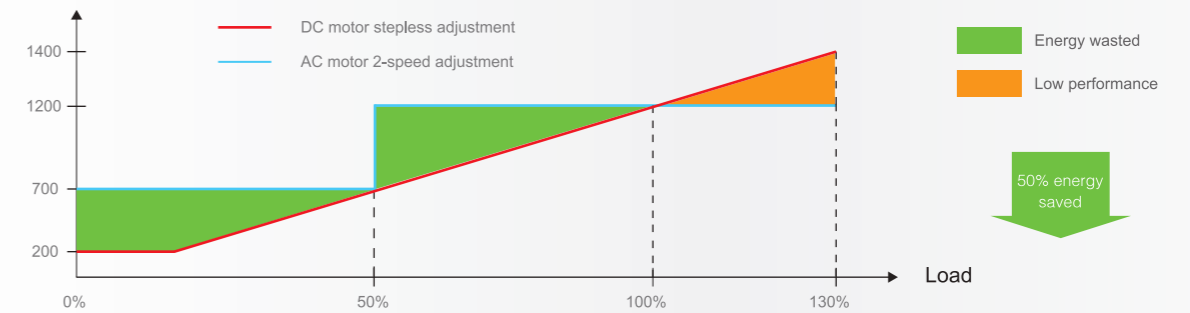

180° Sine Waveform Control

CMV-X+	CMV-X	CMV-R
●	●	●

The perfect combination of 180° Sine waveform rotor frequency drive control technology and excellent IPM inverters, reduces the reactive loss of motor-driven, increases motor efficiency by 12%.

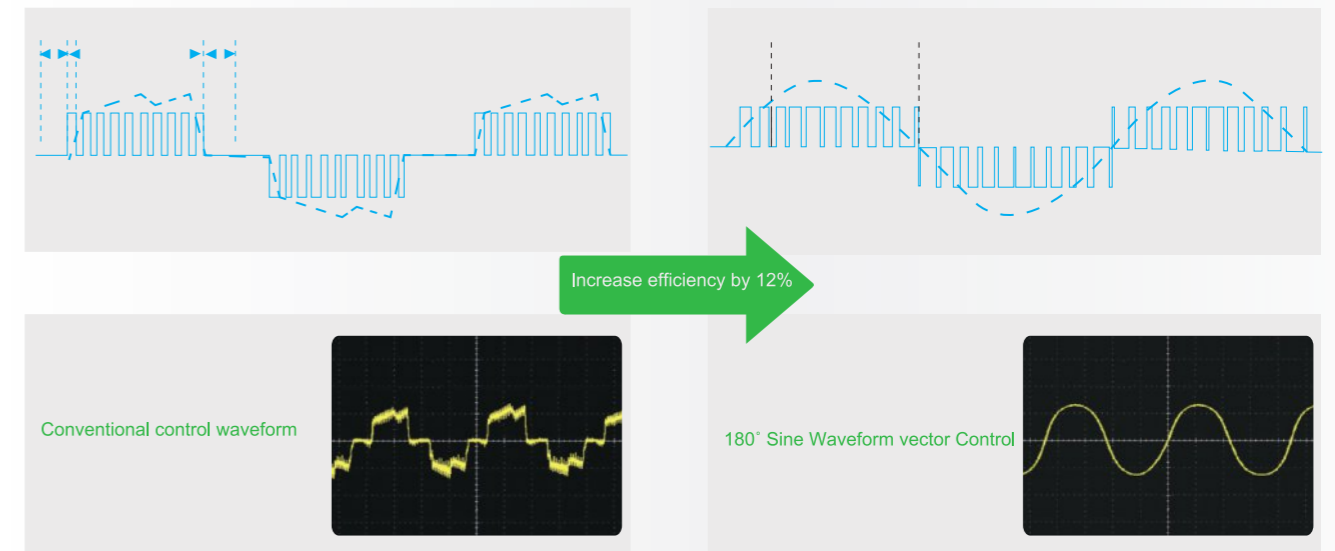

CCT Inner-grooved Tube

CMV-X+	CMV-X	CMV-R
●	●	●

CCT(Continuous Cooling Transformation) inner-grooved copper tube has high thermometric conductivity. This inner-grooved fins break the refrigerant flow boundary layer to enhance refrigerant disturbance to increase heat-exchanging efficiency.

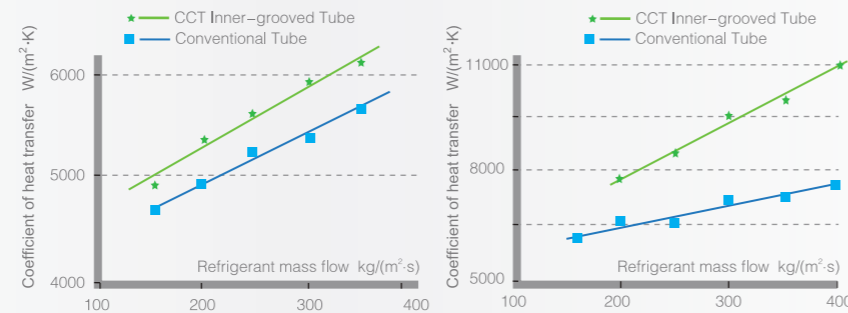
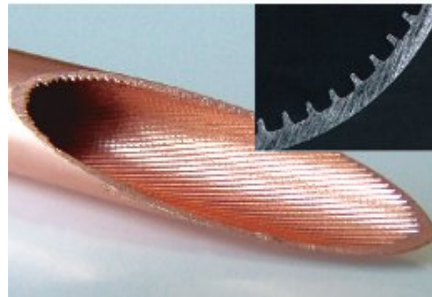

Supercooling Flow Path Design

CMV-X+	CMV-X	CMV-R
●	●	●

Supercooling flow path design, separates the refrigerant inlet and outlet, increase the supercooling degree, reduce the effect of high temperature inlet gas refrigerant to low temperature outlet liquid refrigerant, therefore, the system efficiency will be greatly increased.

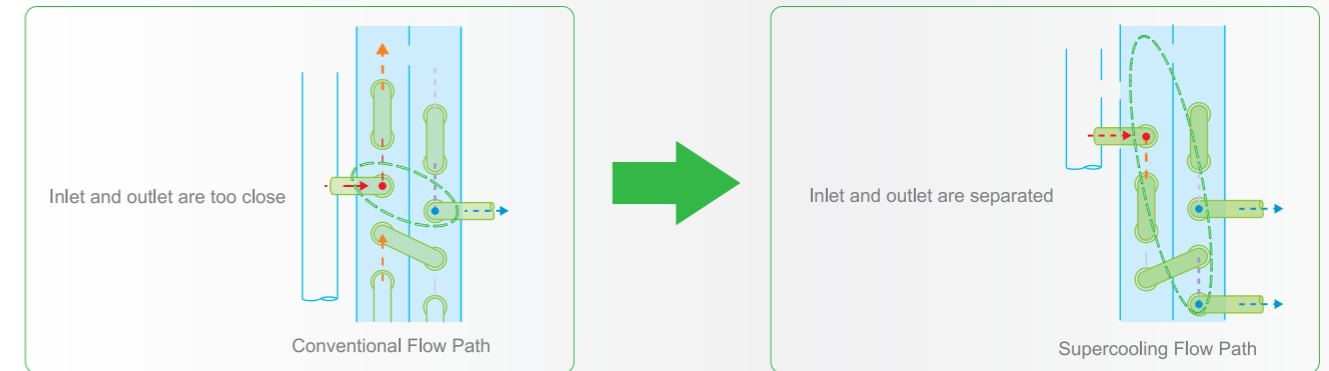

2-in-1 Refrigerant Flow Path Design

CMV-X+	CMV-X	CMV-R
●	●	●

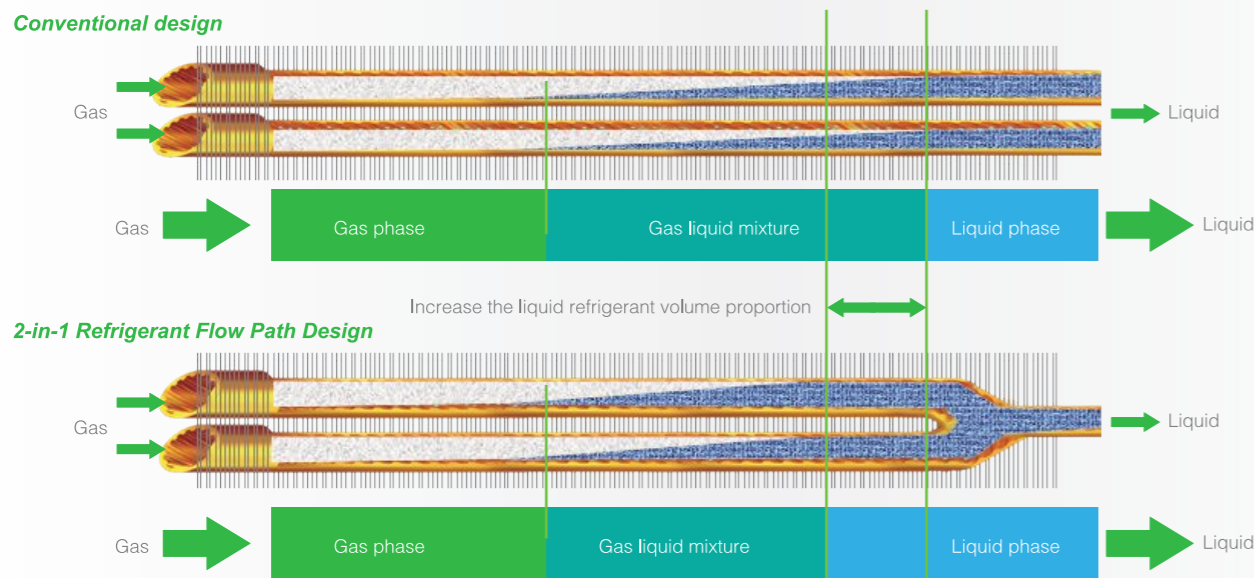
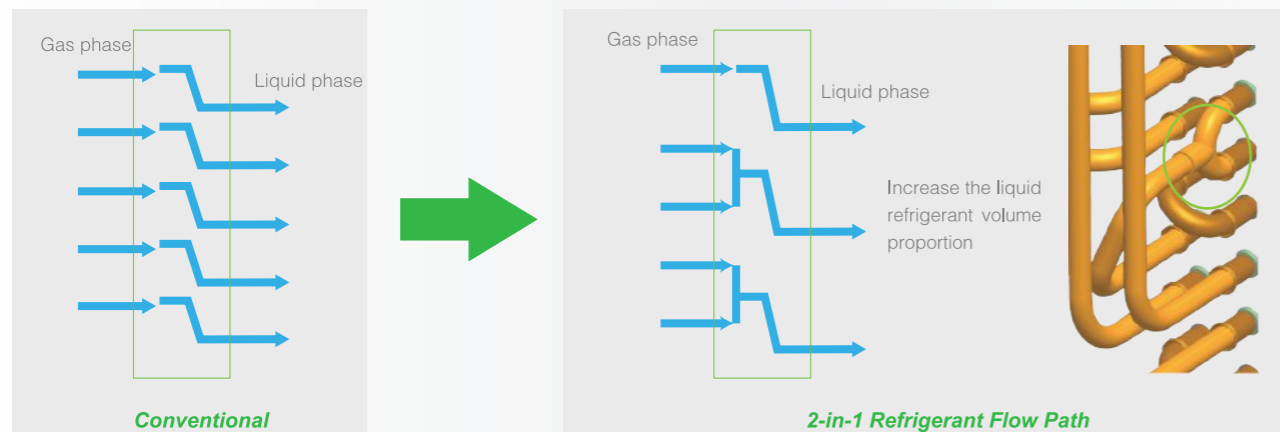

Cross Flow Fins

CMV-X+	CMV-X	CMV-R
●	●	●

- Has low air resistance and great heat transfer coefficient.
- Frosting improved, frost on the heat-exchanger will be well-distributed, easy for defrosting.

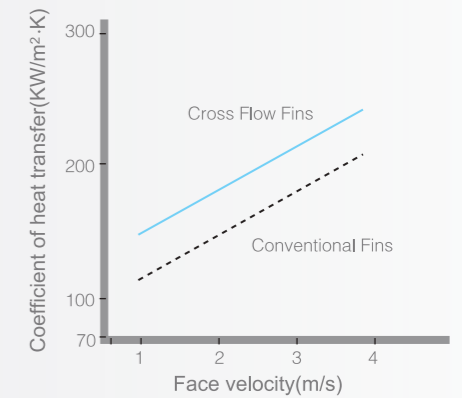
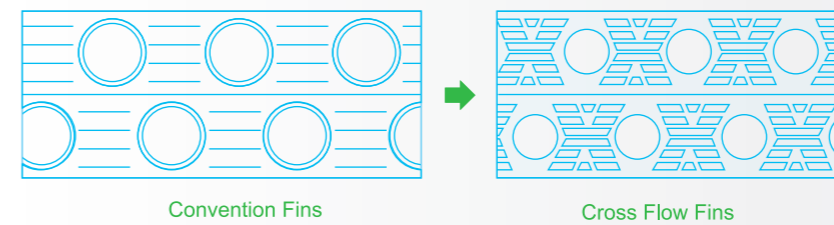

Low Resistance Internal piping

CMV-X+	CMV-X	CMV-R
●	●	●

- Thanks to the optimization pipeline design, 5% pressure drop are reduced.
- EER and COP increase, because of evaporating temperature increase and compressor work decrease.

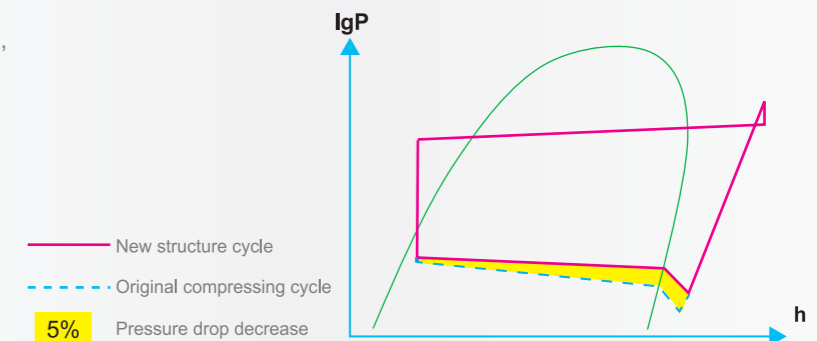

Benefits For Users

Livable environment creator

Chigo focuses on starting point of AC system: create a friendly, comfortable and pleasant living environment as always. New CMV DC VRF system's comfort technologies include quick cooling and heating, precise temperature control, low noise, use environmental friendly refrigerant and so on, we strive to create livable environment for users.....



Outstanding Comfort Ability

CMV-X+	CMV-X	CMV-R
●	●	●

- Chigo CMV system have excellent cooling & heating performance, thanks to the high efficiency DC fan motor, DC compressor and optimized refrigerant flow control logic.
- Precisely room temperature control by adopting 2000 pulse EXV. Indoor temperature fluctuation can be maintain within 0.5 C, offers outstanding comfort ability.

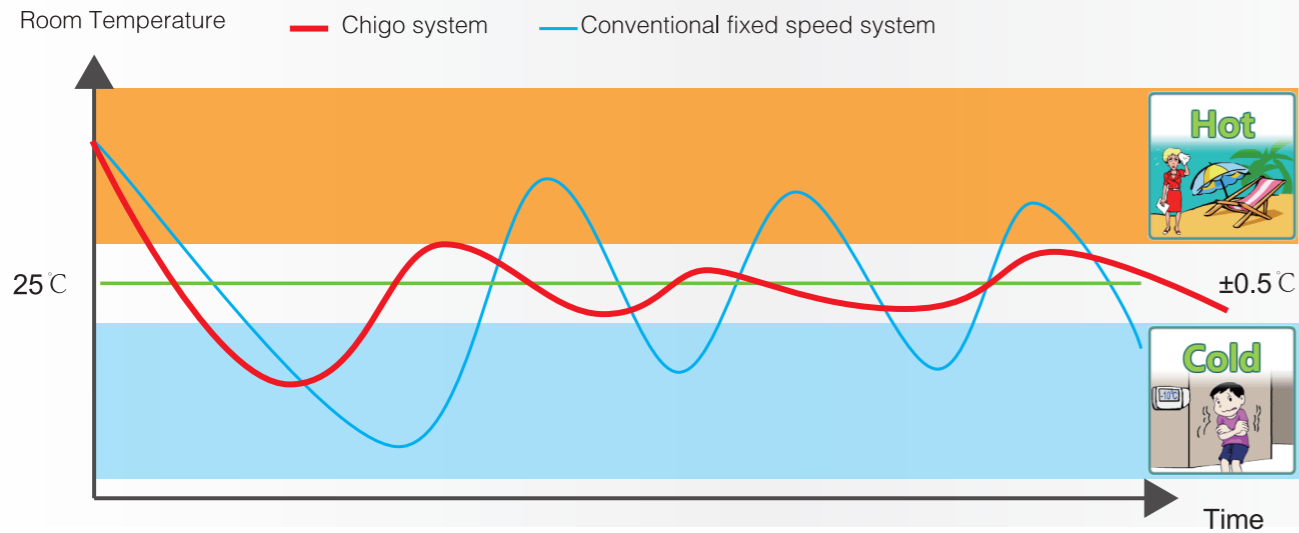

Wide Operation Range

CMV-X+	CMV-X	CMV-R
●	●	●

- Cooling operating temperature is up to 50°C, suitable for the hot region. For T3 VRF units, the cooling operating temperature is up to 55°C.
- Heating operating temperature is down to -20°C. In the cold winter, CMV system can stably produce heat.
- Mix mode operating temperature is up to 25°C
- Heating operating temperature is down to -20°C. In the cold winter, CMV system can stably produce heat.

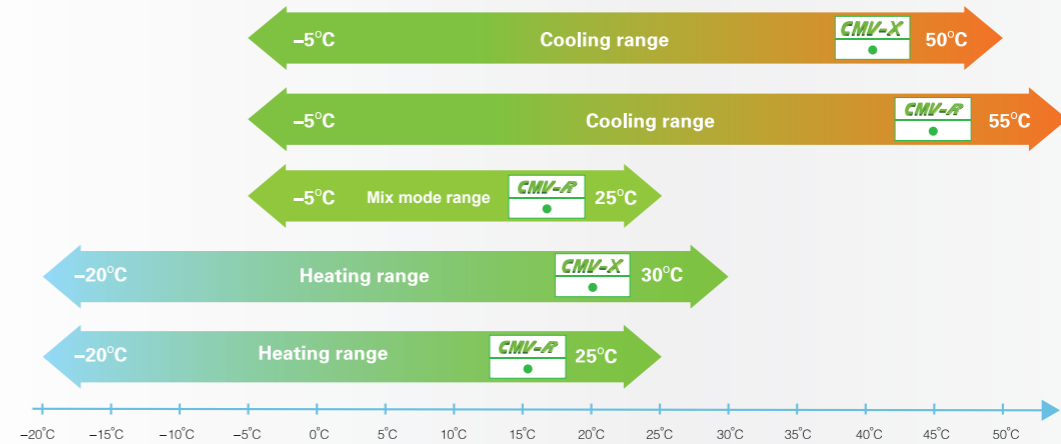

- Outdoor unit running at temperature above 50°C need customized in factory, please consult to sales engineer.

7 Improvements To Reduce Noise

CMV-X+	CMV-X	CMV-R
●	●	●

Maximum 10dB(A) of operating sound decrease.



Low Noise Fan Blade

CMV-X+	CMV-X	CMV-R
●	●	●

- Anti-vibration forward fan blade.
- Special design to reduce the air vibration and disturbance.

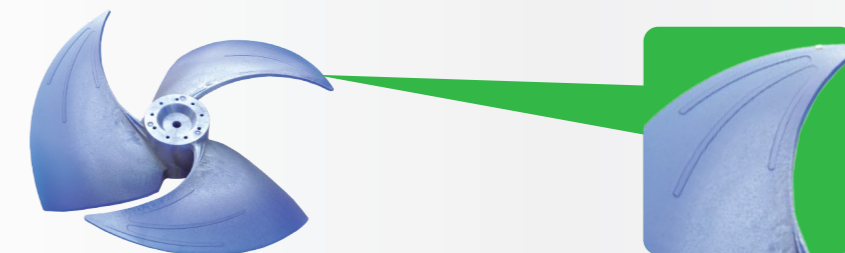

Silent Mode, Night Time Noise Control

CMV-X+	CMV-X	CMV-R
●	●	●

- Compressor and fan motor rotating speed can be reduced to lower the noise at night.
- Maximum 10dB(A) decrease.

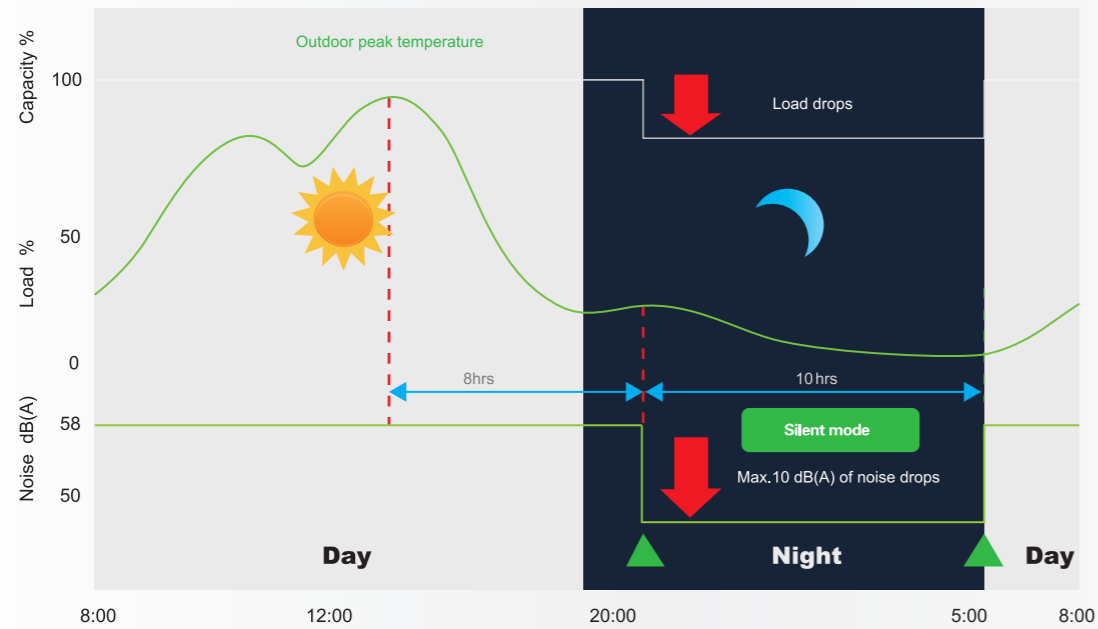

Snow-proof Function

CMV-X+	CMV-X	CMV-R
●	●	●

- In the cold weather, outdoor fan will start to run for a while at intervals, for preventing the snow to accumulate on fan blade. Because accumulated snow will freeze and block fan blade rotating, even worse it will damage the motor.
- It only start when temperature is lower than 0°C.



The PHE Economizer

CMV-X+	CMV-X	CMV-R
●	●	●

- PHE Economizer technology provide a additional sub cooling .
- Improved heat exchanger + PHE economizer + Optimized control logic
- Heating performance highly increased

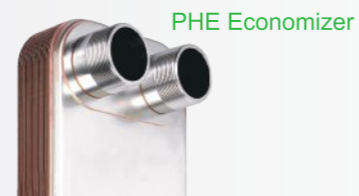

The PHE economizer need customization.

3-stage Back Up Function

CMV-X+	CMV-X	CMV-R
●	●	●

- Module back up function.
- When some modules are failure, the others can keep running by simply settings.

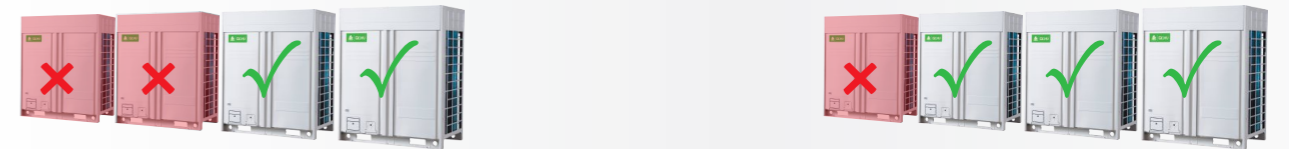

- Compressor back up function
- When one compressor is failure, the other one can keep running by simply settings.



- Fan motor back up function.
- When one fan motor is failure, the other one can keep running by simply settings.



All Outdoor Units Cycle Operation

CMV-X+	CMV-X	CMV-R
●	●	●

- In one combination system, any outdoor unit can run as master unit.
- Balance the lifespan among outdoor units in one system.

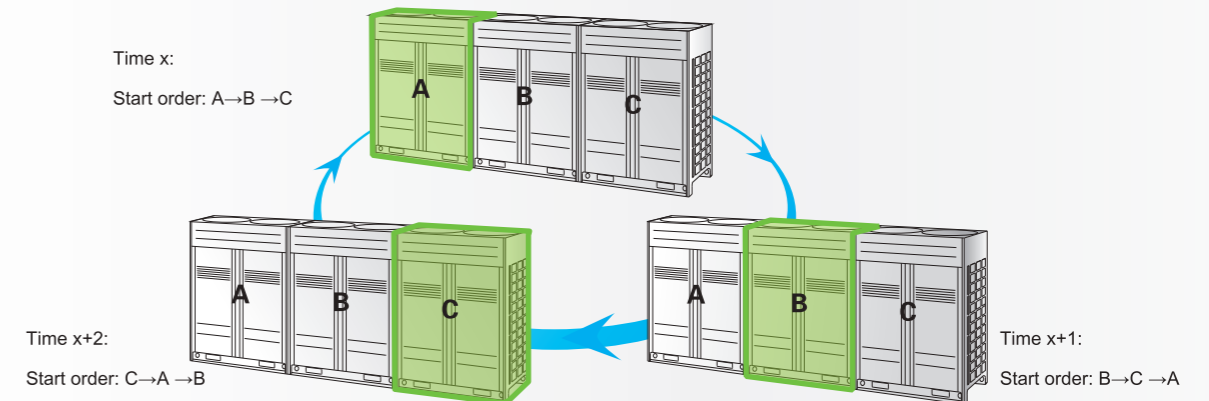

Intelligent Defrosting Program

CMV-X+	CMV-X	CMV-R
●	●	●

Program starts only when unit needs to. Whereas conventional unit's defrosting timing & duration is fixed, causing fluctuations in temperature and personal comfort.

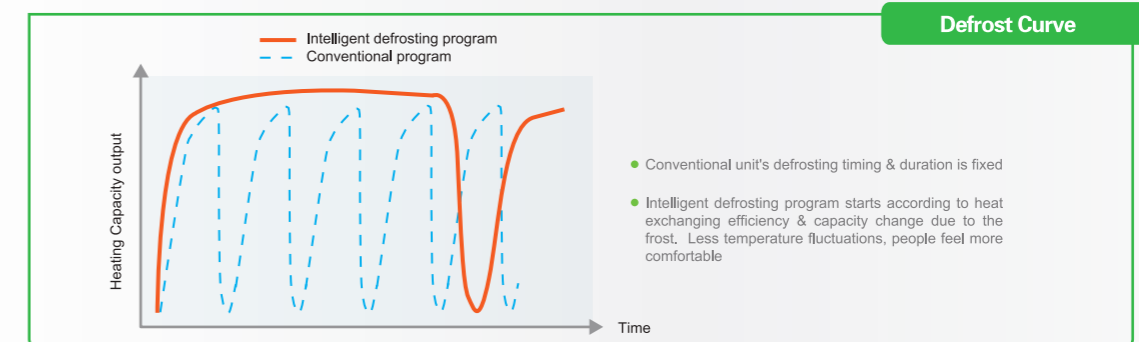

- Conventional unit's defrosting timing & duration is fixed
- Intelligent defrosting program starts according to heat exchanging efficiency & capacity change due to the frost. Less temperature fluctuations, people feel more comfortable

Remote ON/OFF Control Function

CMV-X+	CMV-X	CMV-R
●	●	●

- Indoor units standard build in with ON/OFF control port.
- It can be used for hotel card control and also can be used for long distance remote ON/OFF control. And no need additional hotel VRF indoor unit control module.
- When contactor is open (card pulled out), indoor unit will be off can not be controlled, current running parameters will be saved in indoor PCB.
- When contactor is close (card insert), indoor unit will recover previous running state.



Emergency Stop Operation Function

CMV-X+	CMV-X	CMV-R
●	●	●

Outdoor unit have a fire alarm linkage signal control function. When emergency situation can stop the whole AC system.



Environment Friendly

CMV-X+	CMV-X	CMV-R
●	●	●

Refrigerant R410A(HFC), low carbon footprint, no harm to Ozone.

R410A(HFC), low carbon footprint, no harm to Ozone.

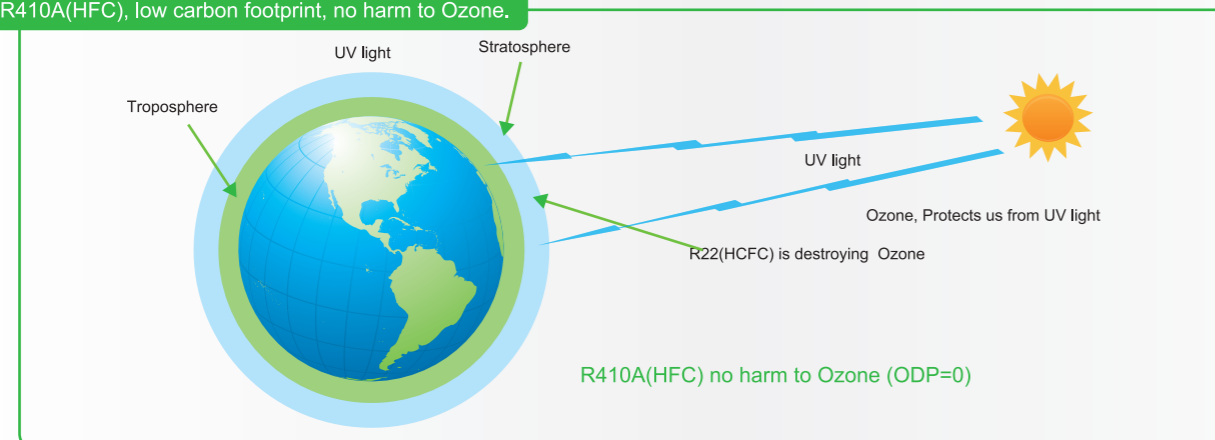

Benefits For Installers



Optimization for designer and installer

CMV DC inverter VRF system is designed with flexible modular combination concept, we keep optimizing the module size, reduce equipment on space occupied to meet the demand of designer and installer. Some unique technologies are used for our installers to reduce their working load, installation is becoming easier and easier!

4 Units Combination, Capacity Up To 88HP

CMV-X+	CMV-X	CMV-R
●		

Max. outdoor units can be combined into a bigger system, capacity can be up to 88HP.



8HP ~ 22HP



24HP ~ 44HP



46HP ~ 66HP



68HP ~ 88HP

4 Units Combination, Capacity Up To 64 HP

CMV-X+	CMV-X	CMV-R
		●



8HP~16HP



18HP~32HP



34HP~48HP



50HP~64HP

Adjustable Outdoor Fan Static Pressure

CMV-X+	CMV-X	CMV-R
●	●	●

- Thanks to DC fan motor, the external static pressure of outdoor fan is adjustable.
- Outdoor units can be installed in the service floor or facility room.
- Maximum ESP 85Pa.

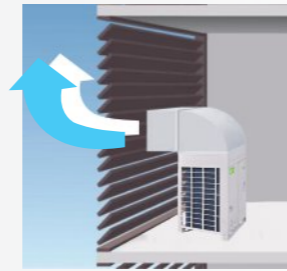

New Wired Controller

CMV-X+	CMV-X	CMV-R
●	●	●

- Bidirectional communication. Indoor unit's operating parameters (error code, temperature, address) can be inquired and displayed on the controller.
- Compact design.
- Timer function.

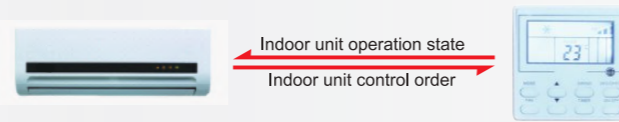

User can check the error code and inquiry unit status very easy, safe and convenient.



Touch Screen Wired Controller

CMV-X+	CMV-X	CMV-R
●	●	●

- Air filter cleaning reminding function.
- Touch screen with black background and white light
- Ultra thin body and stylish design meet high-end environments.
- On/off, temperature setting, fan speed setting, mode setting, timer and check function.



Automatic Addressing

CMV-X+	CMV-X	CMV-R
●	●	●

- Automatic addressing will reduce artificial faults by 35% and 5% manual works.
 - 54% system failure were caused by communication faults.
 - 65% communication faults were caused by address problems.
 - Most of the address problems were: address setting forgotten, wrong settings, address repeat.

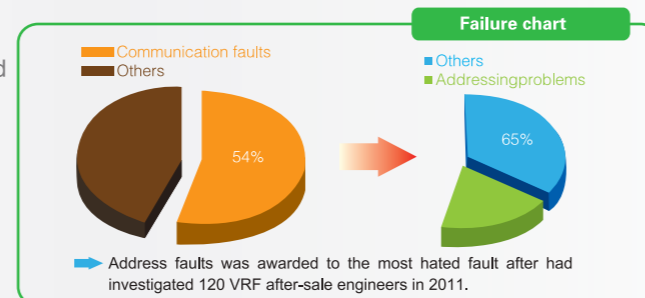

Addressing Methods

CMV-X+	CMV-X	CMV-R
●	●	●

- 2 addressing methods:
 - Automatically addressing: system will distribute address to indoor unit automatically.
 - Manually setting by wireless remote controller.
- Addressing method can be selected easily by adjusting the switch on outdoor PCB.



LED Display On The PCB

CMV-X+	CMV-X	CMV-R
●	●	●

- LED display on the PCB, it can show system's operation status and error codes.
- Record error code list at main PCB chip, easy for service people to check.(CMV-X+ ONLY)



Service Window

CMV-X+	CMV-X	CMV-R
●	●	●

Thanks to the service window, checking outdoor unit's status and setting is now easy, no need to remove the electric control box cover.



Mode Restriction

CMV-X+	CMV-X	CMV-R
●	●	●

- 6 kinds of mode restriction
 - Auto priority(Default Setting)
 - Cooling(or heating)priority mode.
 - Cooling only(or heating only)mode.
 - VIP unit priority
- Mode restriction function can be selected on the outdoor PCB.

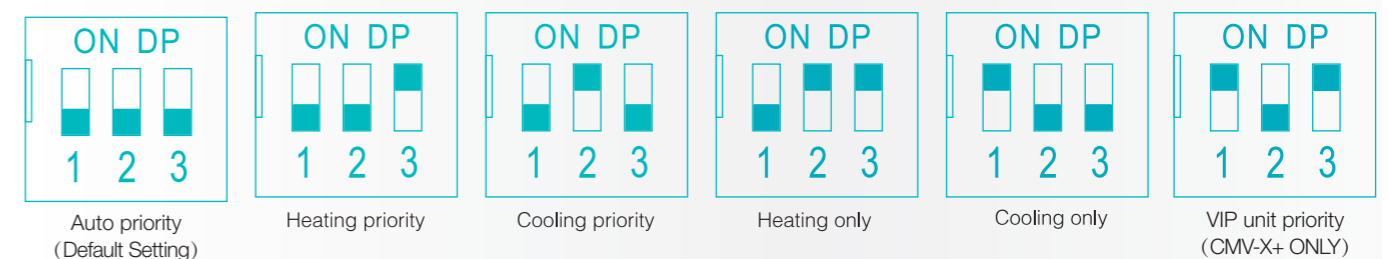

Humanized Internal Structure

CMV-X+	CMV-X	CMV-R
●	●	●

- All key components are designed to close to outside, it is convenient for repair and replacement.
- Thanks to the new balance technology, gas balance pipe does no longer exist, brazing points and leaking risk are decreased.



3-Phase Power Protector (Optional)

CMV-X+	CMV-X	CMV-R
●	●	●

Protect the outdoor unit from instable voltage.

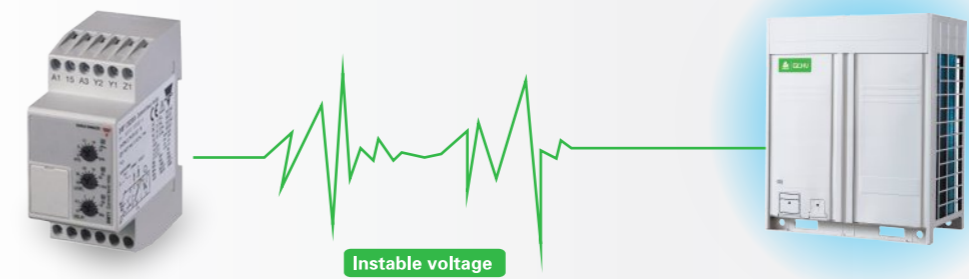

6-Stage Oil Control

CMV-X+	CMV-X	CMV-R
●	●	●

1st stage: Compressor internal oil separation

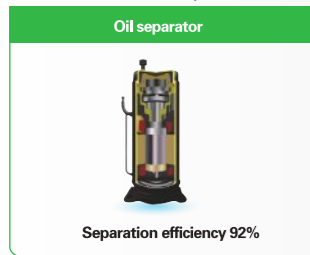

2nd stage: Oil return from the oil even pipe



3rd stage: Oil return from the system oil separator



4th stage: Oil balance between compressors

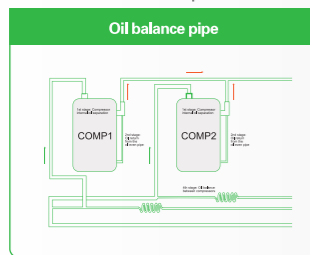

5th stage: Oil balance between outdoor units

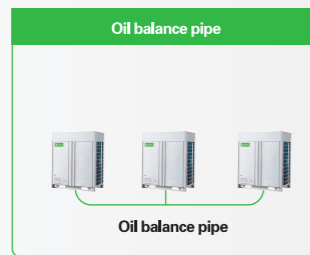

6th stage: Oil return by system oil return program

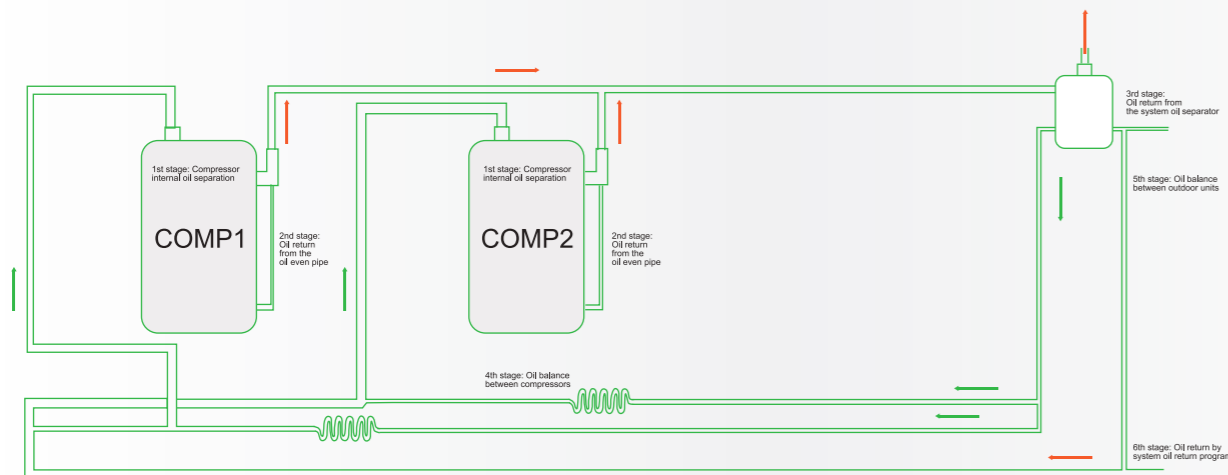
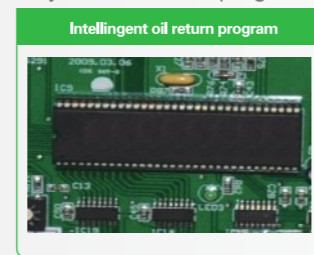

Easy Installation

CMV-X+	CMV-X	CMV-R
●	●	●

- Easy for the outdoor unit to transport to roof floor by elevator due to its compact size.
- Communication wire length can be up to 1000m.

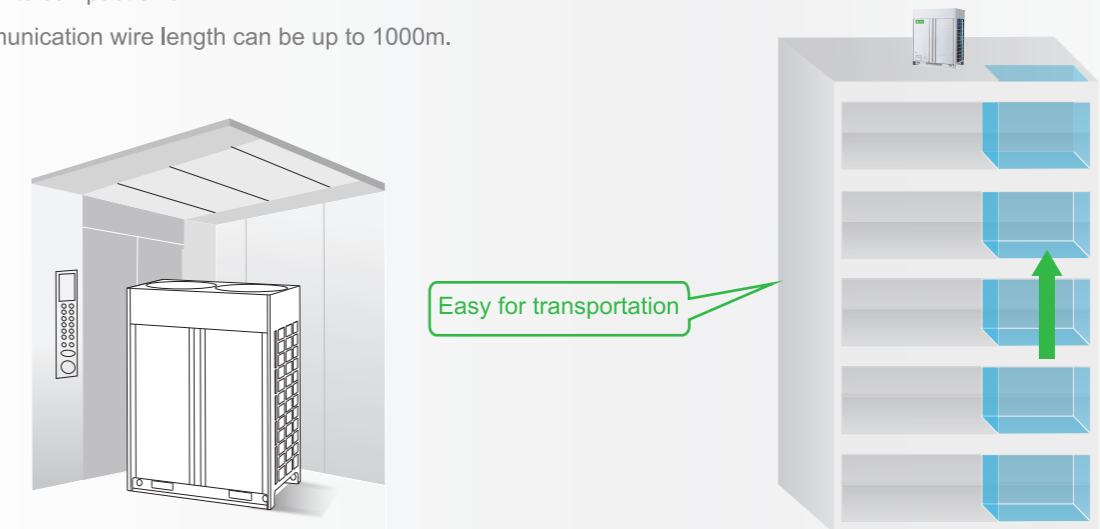

Use 2-Core Shielded Wire As Signal Wire

CMV-X+	CMV-X	CMV-R
●	●	●

- Save installation cost.
- Reduce manual works.





**380V - 415V / 50Hz & 60Hz
TROPICAL TYPE (T3 TYPE) FULL DC INVERTER VRF SYSTEM**

CMV-X+			Basic modules								2 modules combination												
HP			08	10	12	14	16	18	20	22	24	26	28	30	32	34	36	38	40	42	44		
Model Name	380~415V/3PH/50Hz		CMV-D252W/ZR1-B	CMV-D280W/ZR1-B	CMV-D335W/ZR1-B	CMV-D400W/ZR1-B	CMV-D450W/ZR1-B	CMV-D500W/ZR1-B	CMV-D560W/ZR1-B	CMV-D615W/ZR1-B	CMV-D670W/ZR1-B	CMV-D730W/ZR1-B	CMV-D780W/ZR1-B	CMV-D840W/ZR1-B	CMV-D895W/ZR1-B	CMV-D950W/ZR1-B	CMV-D1010W/ZR1-B	CMV-D1065W/ZR1-B	CMV-D1120W/ZR1-B	CMV-D1175W/ZR1-B	CMV-D1230W/ZR1-B		
	380~415V/3PH/60Hz		CMV-D252W/YR1-B	CMV-D280W/YR1-B	CMV-D335W/YR1-B	CMV-D400W/YR1-B	CMV-D450W/YR1-B	CMV-D500W/YR1-B	CMV-D560W/YR1-B	CMV-D615W/YR1-B	CMV-D670W/YR1-B	CMV-D730W/YR1-B	CMV-D780W/YR1-B	CMV-D840W/YR1-B	CMV-D895W/YR1-B	CMV-D950W/YR1-B	CMV-D1010W/YR1-B	CMV-D1065W/YR1-B	CMV-D1120W/YR1-B	CMV-D1175W/YR1-B	CMV-D1230W/YR1-B		
Max. Connected indoor units quantity										28	28	28	32	32	36	36	36	42	42	42			
Cooling	Capacity	KW	25.2	28.0	33.5	40.0	45.0	50.0	56.0	61.5	67.0	73.0	78.0	83.5	89.5	95.0	101.0	106.5	111.5	117.5	123.0		
		Btu/h	86000	95500	114000	136500	153500	170600	191000	209800	228000	249000	266000	284000	305000	324000	344000	363000	380000	400000	419000		
		RT	7.2	8.0	9.5	11.4	12.8	14.2	16.0	17.5	19.0	20.7	22.1	23.7	25.4	27.0	28.7	30.2	31.7	33.4	34.9		
	Power input	EER	4.72	4.54	4.20	4.01	3.72	3.98	3.82	3.76	4.20	3.97	4.14	4.07	3.95	3.90	3.77	3.74	3.86	3.79	3.76		
Heating	Capacity	KW	27.4	31.5	37.5	45.0	50.0	56.0	63.0	69.0	75.0	81.5	87.5	93.5	100.5	106.5	113.0	119.0	125.0	132.0	138.0		
		Btu/h	93500	107500	128000	153500	170600	191000	214900	235000	255000	278000	298000	319000	342000	363000	385000	406000	426000	450000	470000		
	Power input	COP	4.98	5.89	7.37	9.53	10.89	11.89	14.22	16.75	14.73	16.78	17.78	19.26	22.64	24.11	25.11	27.64	28.64	30.97	33.50		
Compressor	Quantity		1DC				2DC				1DC+1DC				1DC+2DC				2DC+2DC				
	Type		Hermatic scroll								Hermatic scroll												
Refrigerant	Type		R410A								R410A												
	Throttle type		EXV								EXV												
Motor	Volume	Kg	10		12		15		15		16		17		17		/						
	Type		1DC				2DC				2DC+2DC				1DC+2DC				2DC+2DC				
Dimension (WxDxH)	Net	mm	970x765x1620				1349x765x1620				/				/								
	Packing	mm	1030x825x1750				1405x825x1780				/				/								
Net weight	Kg	208		220		287		314		325		/		/		/		/		/			
Sound pressure level	dB(A)	58		60		61		62		63		/		/		/		/		/			
Total equivalent pipeline length ≥ 90m	Liquid	mm	Ø9.52		Ø12.7		Ø15.88		Ø15.88		Ø19.05		Ø19.05		Ø19.05		Ø19.05		Ø19.05				
	Gas	mm	Ø22.2		Ø25.4		Ø28.6		Ø31.80		Ø31.8		Ø34.9		Ø34.9		Ø38.1		Ø38.1				
Total equivalent pipeline length ≥ 90m	Liquid	mm	Ø12.7		Ø15.88		Ø19.05		Ø19.05		Ø22.2		Ø22.2		Ø22.2		Ø22.2		Ø22.2				
	Gas	mm	Ø25.4		Ø28.6		Ø31.8		Ø34.9		Ø34.9		Ø38.1		Ø38.1		Ø41.3		Ø41.3				
Oil balance pipe	mm	Ø6.35																					

CMV-X+			3 modules combination								3 modules combination				4 modules combination											
HP			46	48	50	52	54	56	58	60	62	64	66	68	70	72	74	76	78	80	82	84	86	88		
Model Name	380~415V/3PH/50Hz		CMV-D1290W/ZR1-B	CMV-D1345W/ZR1-B	CMV-D1400W/ZR1-B	CMV-D1455W/ZR1-B	CMV-D1510W/ZR1-B	CMV-D1565W/ZR1-B	CMV-D1625W/ZR1-B	CMV-D1680W/ZR1-B	CMV-D1730W/ZR1-B	CMV-D1790W/ZR1-B	CMV-D1845W/ZR1-B	CMV-D1905W/ZR1-B	CMV-D1960W/ZR1-B	CMV-D2015W/ZR1-B	CMV-D2070W/ZR1-B	CMV-D2125W/ZR1-B	CMV-D2180W/ZR1-B	CMV-D2240W/ZR1-B	CMV-D2295W/ZR1-B	CMV-D2345W/ZR1-B	CMV-D2405W/ZR1-B	CMV-D2460W/ZR1-B		
	380~415V/3PH/60Hz		CMV-D1290W/YR1-B	CMV-D1345W/YR1-B	CMV-D1400W/YR1-B	CMV-D1455W/YR1-B	CMV-D1510W/YR1-B	CMV-D1565W/YR1-B	CMV-D1625W/YR1-B	CMV-D1680W/YR1-B	CMV-D1730W/YR1-B	CMV-D1790W/YR1-B	CMV-D1845W/YR1-B	CMV-D1905W/YR1-B	CMV-D1960W/YR1-B	CMV-D2015W/YR1-B	CMV-D2070W/YR1-B	CMV-D2125W/YR1-B	CMV-D2180W/YR1-B	CMV-D2240W/YR1-B	CMV-D2295W/YR1-B	CMV-D2345W/YR1-B	CMV-D2405W/YR1-B	CMV-D2460W/YR1-B		
Max. Connected indoor units quantity			48	48	54	54	54	58	58	58	64	64	64	64	64	64	64	64	64	64	64	64	64	64		
Cooling	Capacity	KW	128.5	134.5	140	145	151	156.5	163	168	173	179	184.5	190	196	201.5	206.5	212.5	218	224.5	229.5	234.5	240.5	246		
		Btu/h	438000	458000	477000	494000	515000	533000	556000	573000	590000	610000	629000	648000	668000	687000	704000	725000	743000	765000	783000	800000	820000	839000		
		RT	36.5	38.2	39.8	41.2	42.9	44.4	46.3	47.7	49.1	50.8	52.4	54	55.7	57.2	58.7	60.4	61.9	63.8	65.2	66.6	68.3	69.9		
	Power input	EER	3.98	3.87	3.84	3.93	3.87	3.85	3.82	3.75	3.82	3.78	3.76	3.90	3.84	3.82	3.88	3.84	3.82	3.80	3.75	3.80	3.77	3.76		
Heating	Capacity	KW	144	150.5	156.5	162.5	169.5	175.5	183	188	194	201	207	213	218	225.5	231.5	238.5	244.5	252	257	263	270	276		
		Btu/h	491000	513000	533000	554000	578000	598000	624000	641000	661000	685000	706000	726000	743000	769000	789000	813000	834000	859000	876000	897000	921000	941000		
	Power input	COP	31.48	33.53	35.01	36.00	39.38	40.86	43.02	44.39	45.38	47.72	50.24	48.23	50.28	51.76	52.75	56.13	57.61	59.78	61.14	62.13	64.46	66.99		
Compressor	Quantity		1DC+2DC+2DC				1DC+2DC+2DC				2DC+2DC+2DC				1DC+2DC+2DC+2DC				1DC+2DC+2DC+2DC				2DC+2DC+2DC+2DC			
	Type		Hermatic scroll								Hermatic scroll															
Refrigerant	Type		R410A								R410A															
	Throttle type		EXV								EXV															
Motor	Volume	Kg	/																							
	Type		1DC+2DC+2DC				1DC+2DC+2DC				2DC+2DC+2DC				1DC+2DC+2DC+2DC				1DC+2DC+2DC+2DC				2DC+2DC+2DC+2DC			
Dimension (WxDxH)	Net	mm	/																							
	Packing	mm	/																							
Net weight	Kg	/																								
Sound pressure level	dB(A)	/																								
Total equivalent pipeline length < 90m	Liquid	mm	Ø19.05		Ø22.2		Ø25.4		Ø25.4		Ø25.4		Ø25.4		Ø25.4		Ø25.4		Ø25.4		Ø25.4		Ø25.4			
	Gas	mm	Ø38.10		Ø44.5		Ø44.5		Ø44.5		Ø44.5		Ø44.5		Ø44.5		Ø44.5		Ø44.5		Ø44.5		Ø44.5			
Total equivalent pipeline length ≥ 90m	Liquid	mm	Ø22.20		Ø25.4		Ø25.4		Ø25.4		Ø25.4		Ø25.4		Ø25.4		Ø25.4		Ø25.4		Ø25.4		Ø25.4			
	Gas	mm	Ø41.30		Ø44.5		Ø44.5		Ø44.5		Ø44.5		Ø44.5		Ø44.5		Ø44.5		Ø44.5		Ø44.5		Ø44.5			
Oil balance pipe	mm	Ø6.35																								

- Notes:1. Cooling operating temperature range is from -5°C to 55°C. Heating operating temperature range is from -20°C to 30°C
- 2. The cooling conditions: T1 condition: indoor side 27°C(80.6°F) DB, 19°C(60°F) WB, outdoor side 35°C(95°F) DB; T3 condition: indoor side 27°C(80.6°F) DB, 19°C(60°F) WB, outdoor side 46°C(114.8°F) DB.
- 3. The heating conditions: indoor side 20°C(68°F) DB, 15°C(44.6°F)WB outdoor side 7°C(42.8°F)DB
- 4. Sound level: measured at a point 1 m in front of the unit at a height of 1.3 m. During actual operation, these values are normally somewhat higher as a result of ambient conditions.
- 5. The above data may be changed without notice for future improvement on quality and performance.

CMV-X 208V-230V / 60Hz FULL DC INVERTER VRF SYSTEM

HP		Basic modules							2 modules combination																									
HP		8	10	12	14	16	18	20	24	26	28	30	32	34	36	38	40	42	44															
Model Name	208~230V/3PH/60Hz	CMV-D252W/XR1	CMV-D280W/XR1	CMV-D335W/XR1	CMV-D400W/XR1	CMV-D450W/XR1	CMV-D500W/XR1	CMV-D560W/XR1	CMV-D670W/XR1	CMV-D730W/XR1	CMV-D780W/XR1	CMV-D840W/XR1	CMV-D895W/XR1	CMV-D950W/XR1	CMV-D1010W/XR1	CMV-D1060W/XR1	CMV-D1120W/XR1	CMV-D1175W/XR1	CMV-D1230W/XR1															
Max. Connected indoor units quantity		13	16	16	20	20	20	24	28	28	28	32	32	36	36	36	42	42	42															
Cooling	Capacity	KW	25.2	28	33.5	40.0	45.0	50.0	56.0	67.0	73.0	78.0	84.0	89.5	95.0	101.0	106.0	112.0	117.5	123.0														
		Btu/h	85000	95000	114000	136000	153000	170500	191000	228000	249000	266000	286000	305000	324000	344000	361000	382000	400000	419000														
	RT	7.1	7.9	9.5	11.3	12.7	14.3	15.9	19.0	20.7	22.1	23.8	25.4	27.0	28.7	30.1	31.8	33.4	34.9															
	Power input	KW	5.79	6.94	8.49	10.59	12.72	14.46	16.68	16.98	19.66	21.40	23.62	25.17	27.18	29.40	31.14	33.36	32.11	33.66														
Heating	Capacity	KW	27.4	31.5	37.5	45.0	50.0	56.0	63.0	75.0	81.5	87.5	94.5	100.5	106.0	113.0	119.0	126.0	132.0	138.0														
		Btu/h	93000	107000	127000	153000	170000	190960	214000	255000	278000	298000	322000	342000	361000	385000	406000	429000	450000	470000														
	Power input	KW	5.89	7.2	8.82	10.99	12.45	14.14	16.02	17.64	19.65	21.34	23.22	25.17	26.59	28.47	30.16	32.04	33.04	33.66														
	COP	W/W	4.65	4.39	4.25	4.00	4.02	3.96	3.93	4.30	4.15	4.10	4.07	3.99	3.99	3.97	3.95	3.93	4.00	4.10														
Compressor	Quantity	1			2				1+1		1+2			2+2				1+1+2																
	Type	Hermetic scroll																																
Refrigerant	Type	R410A																																
	Throttle type	EXV																																
Motor	Volume	10			12		16		15		16.5		12+12		10+16		10+15		10+16.5		12+16.5		16+15		16+16.5		15+16.5		16.5+16.5		10+12+16.5		12+12+16.5	
	Type	DC motor																																
Dimension (WxDxH)	Net	970×765×1620			1260×765×1620				1349×765×1620		/		/		/		/		/		/		/		/		/		/		/			
	Packing	1030×825×1750			1315×825×1750				1405×825×1780		/		/		/		/		/		/		/		/		/		/		/			
Net weight	Kg	208			242		286		305		320		/		/		/		/		/		/		/		/		/					
Sound pressure level	dB(A)	58			60		63		/		/		/		/		/		/		/		/		/		/		/					
Total equivalent pipeline length < 90m	Liquid	Ø9.52			Ø12.7		Ø15.88		Ø15.88		Ø19.05		Ø19.05		Ø19.05		Ø19.05		Ø19.05															
	Gas	Ø22.2			Ø25.4		Ø28.6		Ø31.8		Ø34.9		Ø38.1		Ø38.1		Ø38.1		Ø38.1															
Total equivalent pipeline length ≥ 90m	Liquid	Ø12.7			Ø15.88		Ø19.05		Ø19.05		Ø22.2		Ø22.2		Ø22.2		Ø22.2		Ø22.2															
	Gas	Ø25.4			Ø28.6		Ø31.8		Ø31.8		Ø34.9		Ø38.1		Ø38.1		Ø38.1		Ø38.1															
Oil balance pipe	mm	/																																

HP		3 modules combination							4 modules combination																											
HP		46	48	50	52	54	56	58	60	62	64	66	68	70	72	74	76	78	80																	
Model Name	208~230V/3PH/60Hz	CMV-D1290W/XR1	CMV-D1340W/XR1	CMV-D1400W/XR1	CMV-D1455W/XR1	CMV-D1520W/XR1	CMV-D1570W/XR1	CMV-D1620W/XR1	CMV-D1680W/XR1	CMV-D1752W/XR1	CMV-D1790W/XR1	CMV-D1850W/XR1	CMV-D1900W/XR1	CMV-D1960W/XR1	CMV-D2015W/XR1	CMV-D2070W/XR1	CMV-D2130W/XR1	CMV-D2180W/XR1	CMV-D2240W/XR1																	
Max. Connected indoor units quantity		48	48	54	54	54	58	58	58	64	64	64	64	64	64	64	64	64	64																	
Cooling	Capacity	KW	129.0	134.0	140.0	145.5	152.0	157.0	162.0	168.0	175.2	179.0	185.0	190.0	196.0	201.5	207.0	213.0	218.0	224.0																
		Btu/h	440000	457000	477000	496000	518000	535000	552000	573000	597000	610000	631000	648000	668000	687000	706000	726000	743000	764000																
	RT	36.6	38.1	39.8	41.3	43.2	44.6	46.0	47.7	49.8	50.8	52.6	54.0	55.7	57.2	58.8	60.5	61.9	63.6																	
	Power input	KW	36.34	38.08	40.30	41.85	43.95	46.08	47.82	50.04	49.17	50.34	53.02	54.76	56.98	58.53	60.54	62.76	64.50	66.72																
Heating	Capacity	KW	144.5	150.5	157.5	163.5	169.0	176.0	182.0	189.0	195.4	201.0	207.5	213.5	220.5	224.0	232.0	239.0	245.0	252.0																
		Btu/h	493000	513000	537000	557000	576000	600000	620000	644000	666000	685000	707000	728000	752000	764000	791000	815000	835000	859000																
	Power input	KW	35.67	37.36	39.24	40.86	43.03	44.49	46.18	48.06	48.31	49.68	51.69	53.38	55.26	56.88	58.63	60.51	62.20	64.08																
	COP	W/W	4.05	4.03	4.01	4.00	3.93	3.96	4.01	3.93	4.04	4.05	4.01	4.00	3.99	3.94	3.96	3.95	3.94	3.93																
Compressor	Quantity	1+2+2			2+2+2				1+2+2+2		2+2+2+2			1+2+2+2				2+2+2+2																		
	Type	Hermetic scroll																																		
Refrigerant	Type	R410A																																		
	Throttle type	EXV																																		
Motor	Volume	10+16+16.5			10+15+16.5		10+16.5+16.5		12+16.5+16.5		16+16.5+16.5		15+16.5+16.5		16.5+16.5+16.5		10+15+15+15		12+12+16.5+16.5		10+16+16.5+16.5		10+15+16.5+16.5		10+16.5+16.5+16.5		12+16.5+16.5+16.5		16+15+16.5+16.5		16+16.5+16.5+16.5		15+16.5+16.5+16.5		16.5+16.5+16.5+16.5	
	Type	DC motor																																		
Dimension (WxDxH)	Net	1+2+2			1+2+2		2+2+2		1+2+2+2		2+2+2+2			1+2+2+2				2+2+2+2																		
	Packing	/																																		
Net weight	Kg	/																																		
Sound pressure level	dB(A)	/																																		
Total equivalent pipeline length < 90m	Liquid	Ø19.05			Ø22.2		Ø22.2		Ø22.2		Ø22.2		Ø22.2		Ø22.2		Ø22.2		Ø22.2																	
	Gas	Ø38.1			Ø44.5		Ø44.5		Ø44.5		Ø44.5		Ø44.5		Ø44.5		Ø44.5		Ø44.5																	
Total equivalent pipeline length ≥ 90m	Liquid	Ø22.2			Ø25.4		Ø25.4		Ø25.4		Ø25.4		Ø25.4		Ø25.4		Ø25.4		Ø25.4																	
	Gas	Ø41.3			Ø44.5		Ø44.5		Ø44.5		Ø44.5		Ø44.5		Ø44.5		Ø44.5		Ø44.5																	
Oil balance pipe	mm	Ø6.35																																		

Notes:
 1. Cooling operating temperature range is from -5°C to 50°C. Heating operating temperature range is from -20°C to 30°C
 2. The cooling conditions: indoor side 27°C(80.6°F) DB, 19°C(60°F)WB outdoor side 35°C(95°F) DB
 3. The heating conditions: indoor side 20°C(68°F) DB, 15°C(44.6°F)WB outdoor side 7°C(42.8°F)DB
 4. Sound level: measured at a point 1 m in front of the unit at a height of 1.3 m. During actual operation, these values are normally somewhat higher as a result of ambient conditions.
 5. The above data may be changed without notice for future improvement on quality and performance.



380-415V/50&60Hz HEAT RECOVERY SYSTEM

HP		Basic modules					20HP-32HP									
HP		8	10	12	14	16	18	20	22	24	26	28	30	32		
Model Name	380~415V/3PH/50Hz	CMV-R252W/ZR1	CMV-R280W/ZR1	CMV-R335W/ZR1	CMV-R400W/ZR1	CMV-R450W/ZR1	CMV-R532W/ZR1	CMV-R560W/ZR1	CMV-R615W/ZR1	CMV-R680W/ZR1	CMV-R730W/ZR1	CMV-R800W/ZR1	CMV-R850W/ZR1	CMV-R900W/ZR1		
	380~415V/3PH/60Hz	CMV-R252W/YR1	CMV-R280W/YR1	CMV-R335W/YR1	CMV-R400W/YR1	CMV-R450W/YR1	CMV-R532W/YR1	CMV-R560W/YR1	CMV-R615W/YR1	CMV-R680W/YR1	CMV-R730W/YR1	CMV-R800W/YR1	CMV-R850W/YR1	CMV-R900W/YR1		
Max. Connected indoor units quantity		13	16	16	20	20	20	24	24	28	28	32	32			
Cooling	Capacity	KW	25.2	28.0	33.5	40.0	45.0	53.2	56.0	61.5	68.0	73.0	78.5	85.0	90.0	
		Btu/h	85000	95000	114000	136000	153000	181600	191000	209000	232000	249000	267000	290000	307000	
		RT	7.1	7.9	9.5	11.3	12.7	14.3	15.9	17.4	19.3	20.7	22.3	24.1	25.5	
	Power input	KW	5.70	6.62	8.03	11.02	13.08	12.32	13.24	14.65	17.64	19.70	21.11	24.10	26.16	
Heating	Capacity	KW	27.4	31.5	37.5	45.0	50.0	58.9	63.0	69.0	76.5	81.5	87.5	95.0	100.0	
		Btu/h	93000	107000	127000	153000	170000	190960	214000	235000	261000	278000	298000	324000	341000	
		Power input	KW	5.88	7.19	8.80	11.00	12.63	13.07	14.38	15.99	18.19	19.82	21.43	23.63	25.26
	COP	W/W	4.66	4.38	4.26	4.09	3.96	4.51	4.38	4.32	4.21	4.11	4.08	4.02	3.96	
Compressor	Quantity	1			2			1+1			1+2			2+2		
Refrigerant	Type	R410A														
	Throttle type	EXV														
	Volume	12			16			12+12	12+12	12+12	12+16	12+16	12+16	16+16	16+16	
Motor	Type	DC motor														
	Quantity	2			2			2+2			2+2			2+2		
	ESP	85														
Dimension (WxHxD)	Net	1260x765x1620														
	Packing	1315x825x1750														
Net weight	Kg	270			310			61			63			64		
Sound pressure level	dB(A)	57	57	58	60	60	61	61	62	63	63	64	64	64		
Liquid Pipe	mm	Ø12.7	Ø12.7	Ø12.7	Ø15.9	Ø15.9	Ø15.9	Ø15.9	Ø15.9	Ø15.9	Ø19.1	Ø19.1	Ø19.1	Ø19.1		
Low Pressure Gas Pipe	mm	Ø22.2	Ø22.2	Ø22.2	Ø25.4	Ø25.4	Ø25.4	Ø25.4	Ø25.4	Ø25.4	Ø34.9	Ø34.9	Ø34.9	Ø34.9		
High Pressure Gas Pipe	mm	Ø19.1	Ø19.1	Ø19.1	Ø22.2	Ø22.2	Ø22.2	Ø22.2	Ø22.2	Ø22.2	Ø28.6	Ø28.6	Ø28.6	Ø28.6		
High Pressure Gas Balance Pipe	mm	Ø19.1	Ø19.1	Ø19.1	Ø19.1	Ø19.1	Ø19.1	Ø19.1	Ø19.1	Ø19.1	Ø19.1	Ø19.1	Ø19.1	Ø19.1		
Oil Balance Pipe	mm	Ø6.35	Ø6.35	Ø6.35	Ø6.35	Ø6.35	Ø6.35	Ø6.35	Ø6.35	Ø6.35	Ø6.35	Ø6.35	Ø6.35	Ø6.35		

HP		34HP-48HP						50HP-64HP													
HP		34	36	38	40	42	44	46	48	50	52	54	56	58	60	62	64				
Model Name	380~415V/3PH/50Hz	CMV-R960W/ZR1	CMV-R1010W/ZR1	CMV-R1065W/ZR1	CMV-R1130W/ZR1	CMV-R1200W/ZR1	CMV-R1250W/ZR1	CMV-R1300W/ZR1	CMV-R1350W/ZR1	CMV-R1432W/ZR1	CMV-R1460W/ZR1	CMV-R1515W/ZR1	CMV-R1580W/ZR1	CMV-R1650W/ZR1	CMV-R1700W/ZR1	CMV-R1750W/ZR1	CMV-R1800W/ZR1				
	380~415V/3PH/60Hz	CMV-R960W/YR1	CMV-R1010W/YR1	CMV-R1065W/YR1	CMV-R1130W/YR1	CMV-R1200W/YR1	CMV-R1250W/YR1	CMV-R1300W/YR1	CMV-R1350W/YR1	CMV-R1432W/YR1	CMV-R1460W/YR1	CMV-R1515W/YR1	CMV-R1580W/YR1	CMV-R1650W/YR1	CMV-R1700W/YR1	CMV-R1750W/YR1	CMV-R1800W/YR1				
Max. Connected indoor units quantity		36	36	36	42	42	42	48	48	54	54	54	58	58	58	64	64				
Cooling	Capacity	KW	96.0	101.1	106.5	113.0	118.0	123.5	130.0	135.0	143.2	146.0	151.5	158.0	163.0	168.5	175.0	180.0			
		Btu/h	327000	344000	363000	385000	402000	421000	443000	460000	488000	498000	516000	539000	556000	574000	597000	614000			
		RT	27.2	28.7	30.2	32.1	33.5	35.1	36.9	38.3	40.7	41.5	43.0	44.9	46.3	47.9	49.7	51.1			
	Power input	KW	24.26	26.32	27.73	30.72	32.78	34.19	37.18	39.24	38.48	39.40	40.81	43.80	45.86	47.27	50.26	52.32			
Heating	Capacity	KW	108.0	113.0	119.0	126.5	131.5	137.5	145.0	150.0	158.9	163.0	169.0	176.5	181.5	187.5	195.0	200.0			
		Btu/h	368000	385000	406000	431000	448000	469000	494000	511000	542000	556000	576000	602000	619000	639000	665000	682000			
		Power input	KW	25.38	27.01	28.62	30.82	32.45	34.06	36.26	37.89	38.33	39.64	41.25	43.45	45.08	46.69	48.89	50.52		
	COP	W/W	4.26	4.18	4.16	4.10	4.05	4.04	4.00	3.96	4.15	4.11	4.10	4.06	4.03	4.02	3.99	3.96			
Compressor	Quantity	1+1+2			1+2+2			2+2+2			1+1+2+2			1+2+2+2			2+2+2+2				
Refrigerant	Type	R410A																			
	Throttle type	EXV																			
	Volume	12+12+16			12+12+16			12+16+16			12+16+16			12+12+16+16			12+16+16+16			12+16+16+16	
Motor	Type	DC motor																			
	Quantity	2			2			2+2			2+2			2+2+2			2+2+2				
	ESP	85																			
Dimension (WxHxD)	Net	/																			
	Packing	/																			
Net weight	Kg	/																			
Sound pressure level	dB(A)	65	65	65	66	67	67	67	67	68	68	68	68	69	69	69	69				
Liquid Pipe	mm	Ø19.1	Ø19.1	Ø19.1	Ø19.1	Ø19.1	Ø19.1	Ø19.1	Ø19.1	Ø22.2	Ø22.2	Ø22.2	Ø22.2	Ø22.2	Ø22.2	Ø22.2	Ø22.2				
Low Pressure Gas Pipe	mm	Ø41.3	Ø41.3	Ø41.3	Ø41.3	Ø41.3	Ø41.3	Ø41.3	Ø41.3	Ø44.5	Ø44.5	Ø44.5	Ø44.5	Ø44.5	Ø44.5	Ø44.5	Ø44.5				
High Pressure Gas Pipe	mm	Ø34.9	Ø34.9	Ø34.9	Ø34.9	Ø34.9	Ø34.9	Ø34.9	Ø34.9	Ø38.1	Ø38.1	Ø38.1	Ø38.1	Ø38.1	Ø38.1	Ø38.1	Ø38.1				
High Pressure Gas Balance Pipe	mm	Ø19.1	Ø19.1	Ø19.1	Ø19.1	Ø19.1	Ø19.1	Ø19.1	Ø19.1	Ø19.1	Ø19.1	Ø19.1	Ø19.1	Ø19.1	Ø19.1	Ø19.1	Ø19.1				
Oil Balance Pipe	mm	Ø6.35	Ø6.35	Ø6.35	Ø6.35	Ø6.35	Ø6.35	Ø6.35	Ø6.35	Ø6.35	Ø6.35	Ø6.35	Ø6.35	Ø6.35	Ø6.35	Ø6.35	Ø6.35				

- Notes: 1. Cooling operating temperature range is from -5°C to 50°C. Heating operating temperature range is from -20°C to 30°C
 2. The cooling conditions: indoor side 27°C(80.6°F) DB, 19°C(60°F)WB outdoor side 35°C(95°F) DB
 3. The heating conditions: indoor side 20°C(68°F) DB, 15°C(44.6°F)WB outdoor side 7°C(42.8°F)DB
 4. Sound level: measured at a point 1 m in front of the unit at a height of 1.3 m. During actual operation, these values are normally somewhat higher as a result of ambient conditions.
 5. The above data may be changed without notice for future improvement on quality and performance.

EMV-mini



EMV-mini

High Efficiency DC Inverter Compressor

- Twin-rotary DC inverter compressor / Hermetic scroll inverter compressor
 - Use high efficiency and reliability compressor
 - Has very good efficiency in part load condition

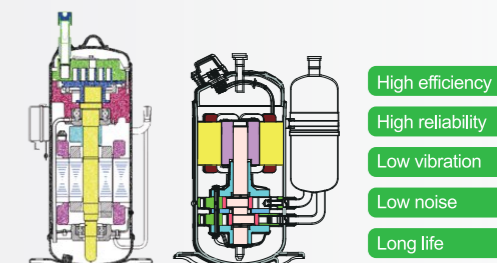

- High Efficiency, Low Noise:

Optimized the efficiency and noise during operation with the latest technology.

- Environmental Protection:

Developed the compressor with alternative refrigerant which can protect environment.

- Low Vibration:

Reduced the vibration during compressor start and operation by using 2CYL Structure, simplified the match of air-conditioning.



High Efficiency DC Motor

- High efficiency DC fan motor
- Low noise and high efficiency because of high-density wire winding engineering
- Brushless with built-in sensor



180° Sine Wave Control

The perfect combination of 180° Sine wave rotor frequency drive control technology and excellent IPM inverters, reduces the reactive loss of motor-driven, increases motor efficiency by 12%.

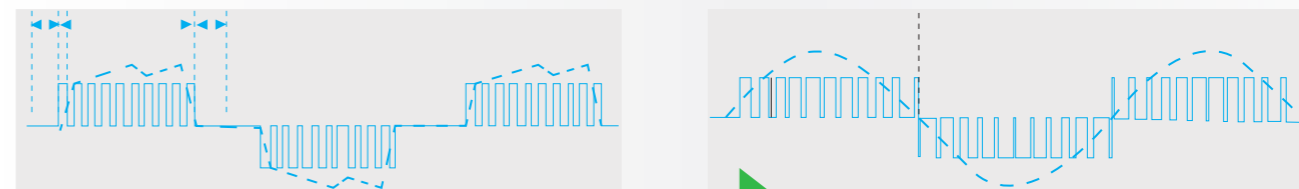

Increase efficiency by 12%

Conventional control waveform

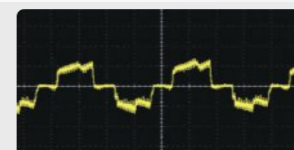

180° Sine Waveform vector Control

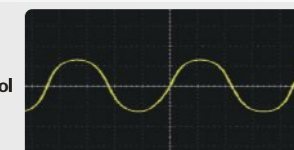

Fast Cooling And Heating

Every rooms meet set point most quickly and comfortably by optimized refrigerant control.

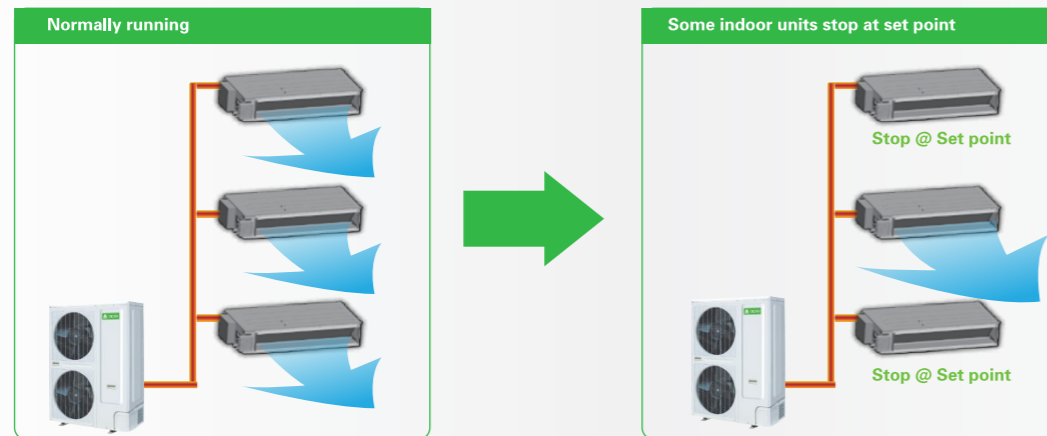

Intelligent Defrosting Program

Program starts only when unit needs to. Whereas conventional unit's defrosting timing & duration is fixed, causing fluctuations in temperature and personal comfort.

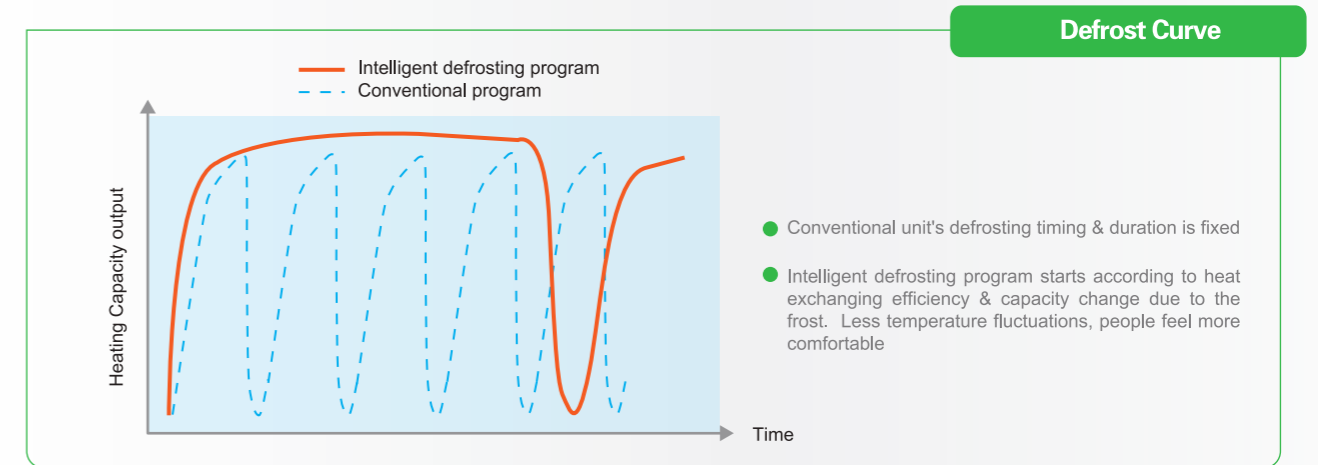

Silent Technology

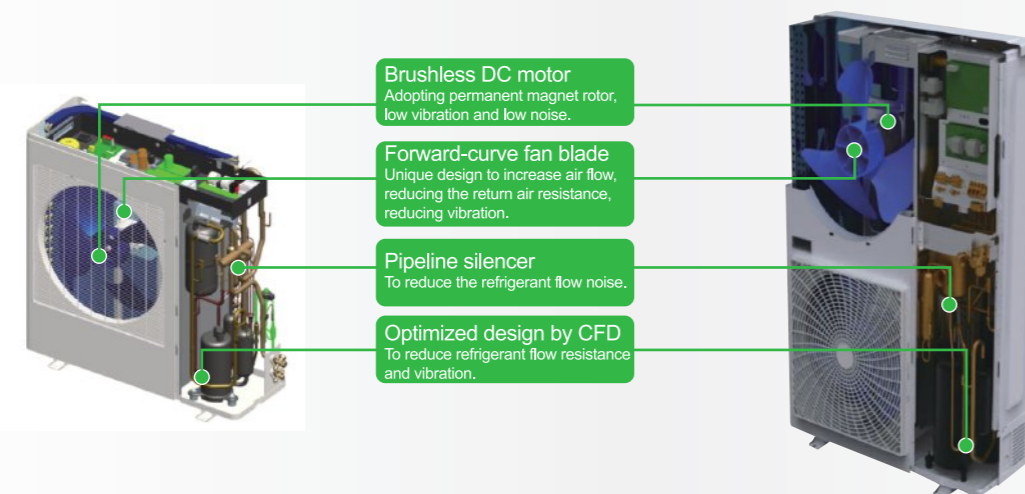

Fan Reversal Protection

In standby, if the outdoor fan motor is rotating in opposite direction at a high speed by the wind or other natural factors, the unit can't start so as to keep the fan motor from broken down. It will start when the fan motor speed slow down.



Wide Outdoor Operation Range

- Because global warming is getting worse, Max. cooling operating temperature is increased to 50°C.
- Heating operating temperature is down to -20°C. In the cold winter, system can heat the room continuously.

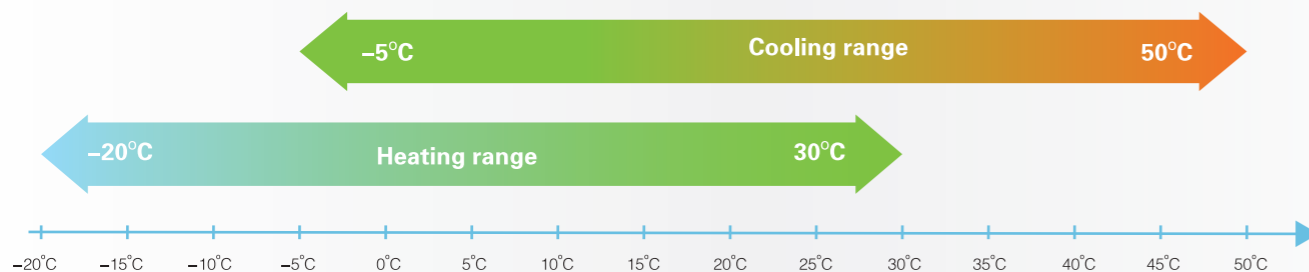

- Outdoor unit running at temperature above 50°C need customized in factory, please consult to sales engineer.

Space Saving Installation

- Multiple indoor units can be connected to 1 outdoor unit, and long piping connection is also possible. Compare to one-drive-one type, the outdoor unit can be installed in various places to realize the
- space-saving installation.



Active PFC Module

- PFC: Power Factor Corrector
- There will be a power loss because of the different phases between the voltage and current.
- With the PFC module, the power utilization rate is higher, power factor can be up to 98%. System will be more efficiency.

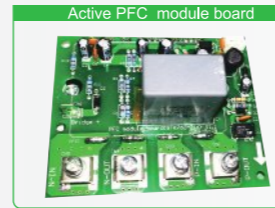

- **Power factor** refers to the relationship between effective power and total power consumption, power factor is effective power divided by total power consumption.
- **Power factor** can measure power utilization rate, the power factor bigger, the higher power utilization rate.

Automatically Addressing

- Automatically addressing: system will distribute address to indoor unit automatically
- Automatic addressing will reduce artificial faults and manual works.

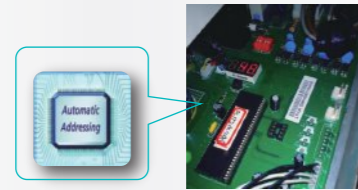

LED Display On PCB

- LED display on the PCB, it can show system's operation status and error codes.

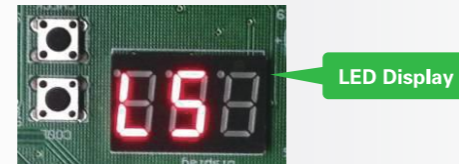









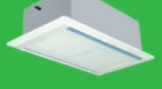

CMV mini Specification

Model name	Power type	Cooling				Heating				Compressor		Motor		Refrigerant	Sound pressure Level dB(A)	Sound power Level dB(A)	Dimension(W×H×D)		Weight		Connecting		Max. Connected indoor units quantity		
		Capacity kW/Btu/h	Power input kW	Current A	EER	Capacity kW/Btu/h	Power input kW	Current A	COP	Type	Quantity	Type	Quantity				Volume kg	Packing mm	Body mm	Net kg	Gross kg	Gas mm		Liquid mm	
CMV-V080W/R1	220-240V-1ph-50Hz	8	27300	2.15	5.70	3.72	9	30700	2.28	6.04	3.95	1			3	45-56	52-63	1145×1120×475	1054×994×399	80	92			4	
CMV-V100W/R1	220-240V-1ph-50Hz	10	34000	2.68	7.10	3.70	11.5	39000	2.90	7.69	3.93				3					80	92			5	
CMV-V125W/R1	220-240V-1ph-50Hz	12.5	42000	3.38	8.96	3.69	14	47000	3.65	9.68	3.83				3.1					89	100			6	
CMV-V125W/ZR1	380-415V-3ph-50Hz	12.5	42000	3.38	5.24	3.69	14	47000	3.66	5.67	3.83				3.1					93	104			6	
CMV-V140W/R1	220-240V-1ph-50Hz	14	47000	3.96	10.50	3.52	16	54000	4.3	11.40	3.72				3.45					89	100	Φ15.9	Φ9.53	7	
CMV-V140W/ZR1	380-415V-3ph-50Hz	14	47000	3.96	6.17	3.52	16	54000	4.3	6.67	3.72				3.45					93	104			7	
CMV-V160W/R1	220-240V-1ph-50Hz	16	54000	4.57	12.11	3.50	18	61000	5.13	13.60	3.61				4.2					96	107			8	
CMV-V160W/ZR1	380-415V-3ph-50Hz	16	54000	4.58	7.10	3.50	18	61000	5.13	7.95	3.61				4.2					100	111			8	
CMV-V180W/ZR1	380-415V-3ph-50Hz	18	61000	5.19	8.05	3.47	20	63000	5.62	8.71	3.56				4.2					100	111	Φ19.1	Φ9.53	9	
CMV-VH224W/ZR1	380-415V-3ph-50Hz	22.4	76500	6.74	10.5	3.32	25	85300	5.85	9.9	4.27				6.1	45-58	52-65			145	165		Φ22.2	Φ9.53	10
CMV-VH260W/ZR1	380-415V-3ph-50Hz	26	88700	7.54	12.1	3.45	28.5	97300	6.77	11.1	4.21				6.1	46-60	55-66			145	165			12	
CMV-VH280W/ZR1	380-415V-3ph-50Hz	28	95500	8.32	13.6	3.37	30.5	104000	7.93	12.9	3.85				8	47-60	56-66	1278×1703×560	1120×1549×528	176	196	Φ25.4	Φ12.7	15	
CMV-VH335W/ZR1	380-415V-3ph-50Hz	33.5	114200	9.45	14.9	3.54	37.5	127900	9	14.2	4.17				8	48-62	57-68			176	196	Φ25.4	Φ12.7	18	
CMV-V080W/XR1	220-240V-1ph-60Hz	8	27300	2.15	5.70	3.72	9	30700	2.28	6.04	3.95				3	45-56	52-63	1145×1120×475	1054×994×399	80	92			4	
CMV-V100W/XR1	220-240V-1ph-60Hz	10	34000	2.68	7.10	3.70	11.5	39000	2.90	7.69	3.93				3					80	92			5	
CMV-V125W/XR1	220-240V-1ph-60Hz	12.5	42000	3.38	8.96	3.69	14	47000	3.65	9.68	3.83				3.1					89	100			6	
CMV-V125W/YR1	380-415V-3ph-60Hz	12.5	42000	3.38	5.24	3.69	14	47000	3.66	5.67	3.83				3.1					93	104			6	
CMV-V140W/XR1	220-240V-1ph-60Hz	14	47000	3.96	10.50	3.52	16	54000	4.3	11.40	3.72				3.45					89	100	Φ15.9	Φ9.53	7	
CMV-V140W/YR1	380-415V-3ph-60Hz	14	47000	3.96	6.17	3.52	16	54000	4.3	6.67	3.72				3.45					93	104			7	
CMV-V160W/XR1	220-240V-1ph-60Hz	16	54000	4.57	12.11	3.50	18	61000	5.13	13.60	3.61				4.2					96	107			8	
CMV-V160W/YR1	380-415V-3ph-60Hz	16	54000	4.58	7.10	3.50	18	61000	5.13	7.95	3.61				4.2					100	111			8	
CMV-V180W/YR1	380-415V-3ph-60Hz	18	61000	5.19	8.05	3.47	20	63000	5.62	8.71	3.56				4.2					100	111	Φ19.1	Φ9.53	9	
CMV-VH224W/YR1	380-415V-3ph-60Hz	22.4	76500	6.74	10.5	3.32	25	85300	5.85	9.9	4.27				6.1	45-58	52-65			145	165		Φ22.2	Φ9.53	10
CMV-VH260W/YR1	380-415V-3ph-60Hz	26	88700	7.54	12.1	3.45	28.5	97300	6.77	11.1	4.21				6.1	46-60	55-66			145	165			12	
CMV-VH280W/YR1	380-415V-3ph-60Hz	28	95500	8.32	13.6	3.37	30.5	104000	7.93	12.9	3.85				8	47-60	56-66	1278×1703×560	1120×1549×400	176	196	Φ25.4	Φ12.7	15	
CMV-VH335W/YR1	380-415V-3ph-60Hz	33.5	114200	9.45	14.9	3.54	37.5	127900	9	14.2	4.17				8	48-62	57-68			176	196	Φ25.4	Φ12.7	18	

Notes:
 1. The cooling conditions: indoor temp.: 27°C DB (80.6°F), 19°C WB (66°F) outdoor temp.: 35°C DB (95°F) equivalent pipe length: 5m drop length: 0m.
 2. The heating conditions: indoor temp.: 20°C DB (68°F), 15°C WB (44.6°F) outdoor temp.: 7°C DB (42.8°F) equivalent pipe length: 5m drop length: 0m.
 3. Sound level: Anechoic chamber conversion value, measured at a point 1 m in front of the unit at a height of 1.2 m. During actual operation, these values are normally somewhat higher as a result of ambient conditions.
 4. The above data may be changed without notice for future improvement on quality and performance.

Indoor Units Line Up

Capacity (KW)	1-way cassette	2-way cassette	4-way cassette	ROUND-FLOW cassette	4-way cassette (compact type)	Floor standing unit
						
2.2	●				●	
2.8	●				●	
3.6	●				●	
4.5	●	●			●	
5.6	●	●	●	●		
7.1	●	●	●	●		
8.0		●	●	●		
9.0			●	●		
10.0			●	●		●
11.2			●	●		●
12.0				●		●
12.5			●	●		●
14.0			●	●		●
15.0						●
16.0			●	●		●

Capacity (KW)	Wall-mounted	Floor Ceiling	Short ceiling concealed ducted unit	Medium ESP ducted unit	High ESP ducted unit	Fresh air processor
						
2.2	●		●			
2.8	●		●			
3.6	●		●			
4.5	●	●	●			
5.6	●	●	●			
7.1	●	●	●	●	●	
8.0		●		●	●	
9.0		●		●	●	
10.0				●	●	
11.2		●				
12.0				●	●	
14.0		●				●
15.0				●		
16.0		●				
20.0					●	
22.4						●
25.0					●	
28.0					●	●
45.0					●	●
56.0					●	●

1-way Cassette



Controller			
Standard	Optional		
Wireless	Wireless	Wired	Centralized
			

Features

Accessories

Plenum box	Air filter	EXV	Drain pump	AC Motor	DC Motor
/	Standard	Standard (built-in)	Standard (built-in)	Standard	/

Slim body, easy to install

Has slim body with 250mm height, it is specially suitable for low suspended ceiling rooms.

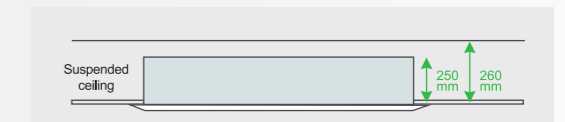

Built-in with drainage pump

Built-in with low noise long life drainage pump, Pumping head is 1200mm, flexible for drainage pipe design.

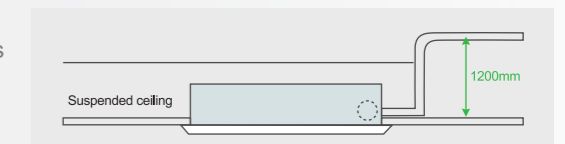

Specification

Model name	Power type	Capacity				Motor input	Air flow	Sound Level	ESP	Dimension (W×H×D)				Body Weight		Connecting pipe			Standard controller
		Cooling kW	Heating kW	Cooling kBlu/h	Heating kBlu/h					Packing mm	Body mm	Panel packing mm	Panel mm	Net kg	Gross kg	Gas mm	Liquid mm	Drain mm	
GMV-V22Q1/HR1-B	50Hz	2.2	7.5	2.5	8.5	0.04	520	306	32~36	1160×275×655	994×250×532	1090×65×540	1070×50×520	24/3.6	30/5.0	Φ6.35	OD Φ25	Remote controller	
GMV-V28Q1/HR1-B	50Hz	2.8	9.5	3.2	10.9														
GMV-V36Q1/HR1-B	50Hz	3.6	12.2	4.0	13.6														
GMV-V45Q1/HR1-B	50Hz	4.5	15.3	5.0	17.0	0.05	610	360	36~41	/	1160×315×655	994×290×532	1090×65×540	1070×50×520	26/3.6	32/5.0	Φ12.7	Remote controller	
GMV-V56Q1/HR1-B	50Hz	5.6	19.1	6.3	21.4	0.07	750	440	35~41										
GMV-V71Q1/HR1-B	50Hz	7.1	24.2	8.0	27.2	0.09	950	550	38~45										1470×305×690

Notes:
 1. Power supply: 220-240V/1PH for 50Hz;
 2. Cooling test condition: indoor side 27°C DB, 19°C WB outdoor side 35°C DB, Heating test condition: indoor side 20°C DB, 15°C WB outdoor side 7°C DB
 3. Sound level: measured at a point 1 m in front of the unit at a height of 1.5 m. During actual operation, these values are normally somewhat higher as a result of ambient conditions.
 4. The above data may be changed without notice for future improvement on quality and performance.

2-way Cassette



Controller			
Standard	Optional		
Wireless	Wireless	Wired	Centralized

4-way Cassette / Round-flow Cassette



Controller			
Standard	Optional		
Wireless	Wireless	Wired	Centralized

Features

Accessories

Plenum box	Air filter	EXV	Drain pump	AC Motor	DC Motor
/	Standard	Standard (built-in)	Standard (built-in)	Standard	/

2 way air direction

Two direction air flow, flexibly install in various rooms or hallway

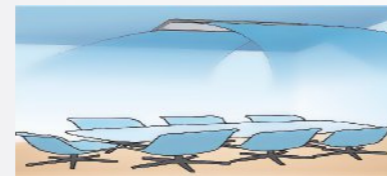

Built-in with drainage pump

Built-in with low noise long life drainage pump, Pumping head is 1200mm, flexible for drainage pipe design.

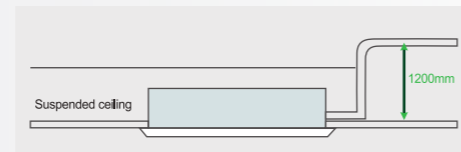

Specification

Model name	Power type	Capacity				Motor input	Air flow	Sound Level	ESP	Dimension (W×H×D)				Body Weight		Connecting pipe			Standard controller	
		Cooling		Heating						Packing	Body	packing	Panel	Net	Gross	Gas	Liquid	Drain		
		kW	kBtu/h	kW	kBtu/h	kW	m³/h	CFM	dB(A)	Pa	mm	mm	mm	mm	kg	kg	mm	mm	mm	
CMVA45Q2HR1-B	50Hz	4.5	15.3	5.0	17	0.07	800	470	36~42		1215×365×630	1068×310×517	1235×70×655	1205×50×630	336.5	368.5	Φ12.7	Φ6.35		Remote controller
CMVA56Q2HR1-B	50Hz	5.6	19.1	6.3	21.4															
CMVA71Q2HR1-B	50Hz	7.1	24.2	8.0	27.2	0.10	1120	650	40~46		1455×365×630	1308×310×517	1475×70×655	1445×50×630	407.5	471/10.0	Φ15.9	Φ9.53		
CMVA80Q2HR1-B	50Hz	8.0	27.2	9.0	30.7															

Notes:
 1. Power supply: 220~240V/1PH for 50Hz;
 2. Cooling test condition: indoor side 27°C DB, 19°C WB outdoor side 35°C DB, Heating test condition: indoor side 20°C DB, 15°C WB outdoor side 7°C DB
 3. Sound level measured at a point 1 m in front of the unit at a height of 1.5 m. During actual operation, these values are normally somewhat higher as a result of ambient conditions.
 4. The above data may be changed without notice for future improvement on quality and performance.

Features

Accessories

Plenum box	Air filter	EXV	Drain pump	AC Motor	DC Motor
/	Standard	Standard (built-in)	Standard (built-in)	Standard	Optional

4 ways air delivering

Air flow is soft and smooth, air can be delivered to every corner without dead angle, it makes the room temperature distribution more balance.



360° round panel is optional.



Built-in with drainage pump

Built-in with low noise long life drainage pump, Pumping head is 1200mm, flexible for drainage pipe design.

Note: The pumping head of 4-way cassette unit (compact type) is 700mm.

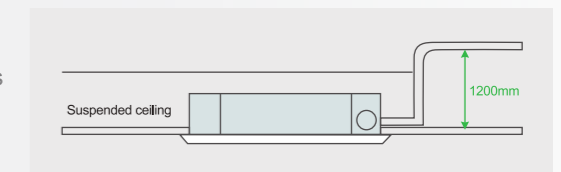

Slim body, easy to install

Has slim body with 230mm height, it is specially suitable for low suspended ceiling rooms.

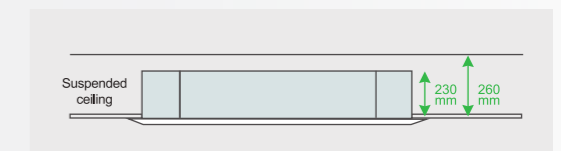

DC fan motor is optional

Specification

4-way Cassette Unit

Model name	Power type	Capacity				Motor input	Air flow		Sound Level	ESP	Dimension (W×H×D)				Body Weight		Connecting pipe			Standard controller					
		Cooling		Heating			m³/h	CFM			Packing	Body	packing	Panel	Net	Gross	Gas	Liquid	Drain						
		kW	kBtu/h	kW	kBtu/h																				
CMV-V56Q/HR1-C	50Hz	5.6	19.1	6.3	21.4	0.054	810	470	35-39	/	920×265×985	833×232×900	1030×105×1030	950×50×950	24	30	Φ12.7	Φ6.35	OD Φ25	Remote controller					
CMV-V56Q/HNR1-C	60Hz																								
CMV-V71Q/HR1-C	50Hz	7.1	24.2	8.0	27.2	0.093	1200	700	36-39																
CMV-V71Q/HNR1-C	60Hz																								
CMV-V80Q/HR1-C	50Hz	8	27.2	8.8	30	0.16	1600	940	37-41																
CMV-V80Q/HNR1-C	60Hz																								
CMV-V90Q/HR1-C	50Hz	9	30.7	10.0	34.1																				
CMV-V90Q/HNR1-C	60Hz																								
CMV-V100Q/HR1-C	50Hz	10	34.1	11.0	37.5																				
CMV-V100Q/HNR1-C	60Hz																								
CMV-V112Q/HR1-C	50Hz	11.2	38.2	12.5	42.6																				
CMV-V112Q/HNR1-C	60Hz																								
CMV-V125Q/HR1-C	50Hz	12.5	42.6	14.0	47.7																				
CMV-V125Q/HNR1-C	60Hz																								
CMV-V140Q/HR1-C	50Hz	14.0	47.7	15.0	51.1																				
CMV-V140Q/HNR1-C	60Hz																								
CMV-V160Q/HR1-C	50Hz	16.0	54.5	17.0	58																				
CMV-V160Q/HNR1-C	60Hz																								

4-way Cassette Unit (Compact type)

Model name	Power type	Capacity				Motor input	Air flow		Sound Level	ESP	Dimension (W×H×D)				Body Weight		Connecting pipe			Standard controller							
		Cooling		Heating			m³/h	CFM			Packing	Body	packing	Panel	Net	Gross	Gas	Liquid	Drain								
		kW	kBtu/h	kW	kBtu/h																						
CMV-V22Q4/HR1-C	50Hz	2.2	7.5	2.5	8.5	0.038	447	263	22-34	/	745×375×675	653×267×585	750×95×750	650×30×650	17.5	25	Φ9.53	Φ6.35	OD Φ25	Remote controller							
CMV-V22Q4/HNR1-C	60Hz																										
CMV-V28Q4/HR1-C	50Hz	2.8	9.5	3.2	10.9	0.038	447	263	22-34																		
CMV-V28Q4/HNR1-C	60Hz																										
CMV-V36Q4/HR1-C	50Hz	3.6	12.2	4.0	13.6	0.040	515	303	27-38																		
CMV-V36Q4/HNR1-C	60Hz																										
CMV-V45Q4/HR1-C	50Hz	4.5	15.3	5.0	17	0.040	515	303	27-38																		
CMV-V45Q4/HNR1-C	60Hz																										

Round-flow Cassette

Model name	Power type	Capacity				Motor input	Air flow		Sound Level	ESP	Dimension (W×H×D)				Body Weight		Connecting pipe			Standard controller										
		Cooling		Heating			m³/h	CFM			Packing	Body	packing	Panel	Net	Gross	Gas	Liquid	Drain											
		kW	kBtu/h	kW	kBtu/h																									
CMV-V56QR/HR1	50Hz	5.6	19.1	6.3	21.4	0.09	860	500	32-39	/	920×265×985	833×232×900	1030×105×1030	950×50×950	24	30	Φ12.7	Φ6.5	Φ25	Remote controller										
CMV-V71QR/HR1	50Hz	7.1	24.2	8.0	27.2																									
CMV-V80QR/HR1	50Hz	8.0	27.2	8.8	30																									
CMV-V90QR/HR1	50Hz	9.0	30.7	10	34.1																									
CMV-V100QR/HR1	50Hz	10	34.1	11	37.5										0.18	1400					820	37-41								
CMV-V112QR/HR1	50Hz	11.2	38.2	12.5	42.6																									
CMV-V125QR/HR1	50Hz	12.5	42.6	14	47.7																									
CMV-V140QR/HR1	50Hz	14	47.7	15	51.1																									
CMV-V160QR/HR1	50Hz	16	54.5	17	58	0.27	1800	1050	38-42																					

- Notes: 1. Power supply: 220-240V/1PH/50Hz;
 2. Cooling test condition: indoor side 27°C DB, 19°C WB outdoor side 35°C DB. Heating test condition: indoor side 20°C DB, 15°C WB outdoor side 7°C DB;
 3. Sound level: measured at a point 1 m in front of the unit at a height of 1.5 m. During actual operation, these values are normally somewhat higher as a result of ambient conditions;
 4. The above data may be changed without notice for future improvement on quality and performance.

Floor standing unit



Controller			
Standard	Optional		
Wireless	Wireless	Wired	Centralized

Features

Accessories

Plenum box	Air filter	EXV	Drain pump	AC Motor	DC Motor
/	Standard	Standard (built-in)	/	Standard	Optional

Anti-dust design

When unit is off, the louvers will close automatically.

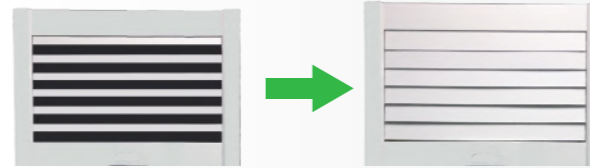

3 dimensional air supply

Two step motor are built in, the air can be easily delivered to every corner.

Specification

Floor Standing Unit

Model name	Power type	Capacity				Motor input	Air flow	Sound Level	ESP	Dimension (W×H×D)				Weight		Connecting pipe			Standard controller
		Cooling kW	Cooling kBtu/h	Heating kW	Heating kBtu/h					Body mm	packing mm	Body kg	packing kg	Gas mm	Liquid mm	Drain mm			
CMV-V100F/HR1	50Hz	10	34.1	11	37.4	0.2	1620	53	/	613×1929×379	745×2080×510	56	72.5	Φ15.9	Φ9.53	Φ25	Remote controller		
CMV-V112F/HR1	50Hz	11.2	38	12.4	42.2														
CMV-V125F/HR1	50Hz	12.5	42.5	13.9	47.3														
CMV-V140F/HR1	50Hz	14	47.6	15.5	52.7														
CMV-V160F/HR1	50Hz	16	54.4	17.8	60.5														

- Notes: 1. Power supply: 220-240V/1PH/50Hz;
 2. Cooling test condition: indoor side 27°C DB, 19°C WB outdoor side 35°C DB. Heating test condition: indoor side 20°C DB, 15°C WB outdoor side 7°C DB;
 3. Sound level: measured at a point 1 m in front of the unit at a height of 1.5 m. During actual operation, these values are normally somewhat higher as a result of ambient conditions;
 4. The above data may be changed without notice for future improvement on quality and performance.

Short Ceiling Concealed Ducted Unit



Controller			
Standard	Optional		
Wired	Wired	Wireless	Centralized

● Slim body, easy to install

Has slim body with 210mm height, it is specially suitable for low suspended ceiling rooms.

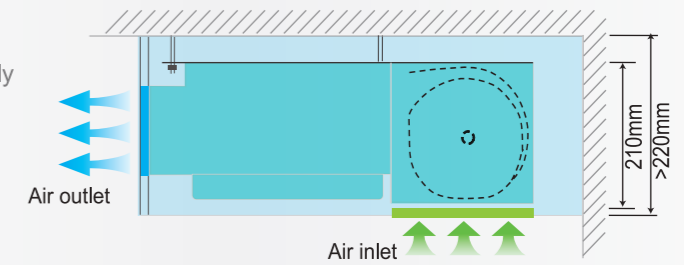

Features

● Accessories

Plenum box	Air filter	EXV	Drain pump	AC Motor	DC Motor
Standard	Optional	Standard (built-in)	Optional	Standard	Optional

● Short body, easy to install.

Has short body, minimum 700mm width, it is specially suitable for installation location in entrance ceiling of hotel room. Low noise and light Weight.

● Drain pump is optional

Pumping head is 750mm.

● DC fan motor is optional

● Big air flow low noise centrifugal fan wheel

Big air flow low noise centrifugal fan blade with special air tunnel system, and the unique shock absorption measures, making this series ducted units' running noise is as low as 24 dB(A), let users to enjoy the comfort, sleep without any disturbance.

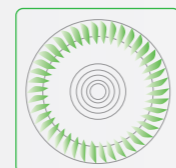

● Special resin material fan wheel.



● All vanes are dislocation distribution to offset sound wave, so that the noise can be reduced.



● High efficiency low noise motor, motor and support frame with rubber ring isolation, can absorb vibration and reduce noise.

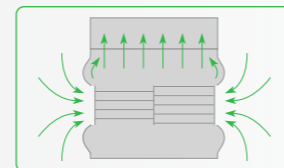

● Air inlet of fan wheel casing is arch curved design; it can reduce air flow's disturbance, make it flow smoother to reduce noise.



Specification

Model name	Power type	Capacity				Motor input	Air flow		Sound Level	ESP	Dimension (W×H×D)				Body Weight		Connecting pipe			Standard controller						
		Cooling		Heating			m³/h	CFM			Packing	Body	Packing	Panel	Net	Gross	Gas	Liquid	Drain							
		kW	kBtu/h	kW	kBtu/h																mm	mm	mm	mm	mm	mm
CMV-V22TA/HR1-C	50Hz	2.2	7.5	2.5	8.5	0.05	450	260	24~29	30	910×240×510	814×210×467	/	/	16	18.5	Φ9.53	OD Φ25	Wired controller							
CMV-V22TA/HNR1-C	60Hz																									
CMV-V28TA/HR1-C	50Hz	2.8	9.5	3.2	10.9																		16	18.5	Φ6.35	OD Φ25
CMV-V28TA/HNR1-C	60Hz																									
CMV-V36TA/HR1-C	50Hz	3.6	12.2	4	13.6	0.07	550	324	25~32							16.5	19	Φ12.7		OD Φ25						
CMV-V36TA/HNR1-C	60Hz																									
CMV-V45TA/HR1-C	50Hz	4.5	15.3	5	17	0.08	620	360	32~37							16.5	19	Φ12.7		OD Φ25						
CMV-V45TA/HNR1-C	60Hz																									
CMV-V56TA/HR1-C	50Hz	5.6	19.1	6.3	21.4	0.09	800	520	28~38			1110×240×510	1010×210×467			21	24	Φ15.9		Φ9.53						
CMV-V56TA/HNR1-C	60Hz																									
CMV-V71TA/HR1-C	50Hz	7.1	24.2	8	27.2	0.11	1000	640	30~39		1310×240×510	1214×210×467			25.5	28.5	Φ15.9	Φ9.53								
CMV-V71TA/HNR1-C	60Hz																									

Notes: 1. Power supply: 220~240V/1PH for 50Hz; 208~230V/1PH for 60Hz.

2. Cooling test condition: indoor side 27°C DB, 19°C WB outdoor side 35°C DB. Heating test condition: indoor side 20°C DB, 15°C WB outdoor side 7°C DB.

3. Sound level: measured at a point 1 m in front of the unit at a height of 1.5 m. During actual operation, these values are normally somewhat higher as a result of ambient conditions.

4. The above data may be changed without notice for future improvement on quality and performance.

Medium Static Pressure Ducted Unit

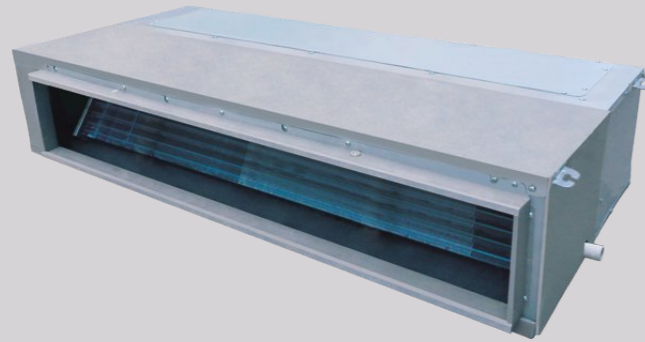

Controller			
Standard	Optional		
Wired	Wired	Wireless	Centralized

Features

Accessories

Plenum box	Air filter	EXV	Drain pump	AC Motor	DC Motor
Standard	Standard	Standard (built-in)	Optional	Standard	Optional

Standard ESP is 70Pa, 30Pa can be customized.

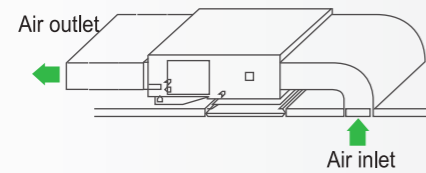

70Pa ESP, suitable for long distance air supply

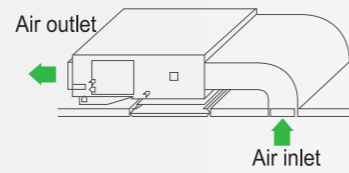

30Pa (can be set on site), suitable for low noise requirement rooms

Convenient in drainage pipe installation

Reserved drainage pipe outlet holes on left side and right side, installer can choose the outlet holes on site as per actual conditions, flexible for drainage pipe installation.

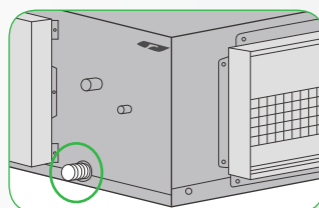

Left drainage hole

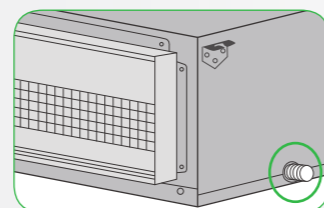

Right drainage hole

Whole unit low noise design, silent operation

Using multiple noise reduction technology, including the design of high efficiency low noise motor, aviation fan wheel, low vibration wheel casing, unique design, the inner wall configuration with high quality insulation materials, and so on, to make the units running in a low noise condition.

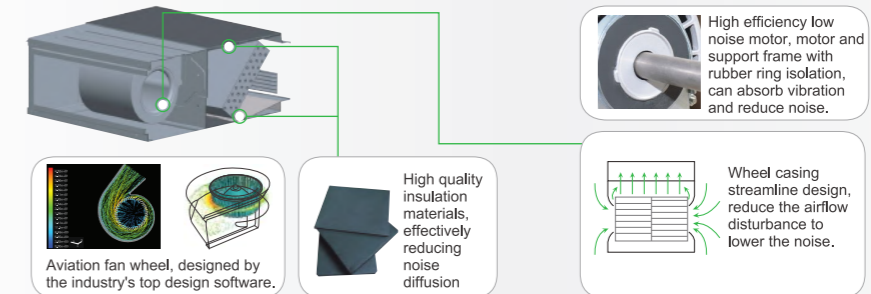

Two air return installation methods

Air return from rear or bottom is easy to change on site, convenient for installation.

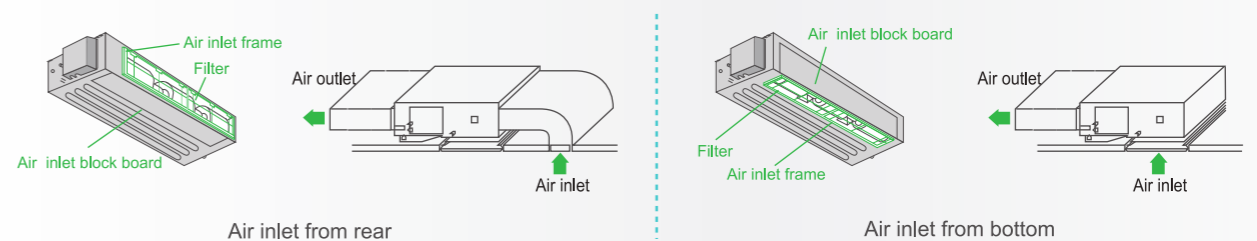

DC fan motor is optional

Specification

Model name	Power type	Capacity				Motor input	Air flow		Sound Level	ESP	Dimension (W×H×D)				Body Weight		Connecting pipe			Standard controller
		Cooling kW	Cooling kBTu/h	Heating kW	Heating kBTu/h		m ³ /h	CFM			Packing mm	Body mm	packing mm	Panel mm	Net kg	Gross kg	Gas mm	Liquid mm	Drain mm	
CMV-V71TB/HR1-B	50Hz	7.1	24.2	8.0	27.2	0.30	1220	710	36-41	70	1255x325x720	1209x260x680			33	37				
CMV-V71TB/HNR1-B	60Hz														33	37				
CMV-V80TB/HR1-B	50Hz	8.0	27.2	9.0	30.7										46	50	Φ15.9	Φ9.53	OD Φ25	Wired controller
CMV-V80TB/HNR1-B	60Hz														46	50				
CMV-V90TB/HR1-B	50Hz	9.0	30.7	10.0	34.1										46	50				
CMV-V90TB/HNR1-B	60Hz														46	50				
CMV-V100TB/HR1-B	50Hz	10.0	34.1	11.0	37.5										46	50				
CMV-V100TB/HNR1-B	60Hz														46	50				
CMV-V120TB/HR1-B	50Hz	12.0	40.9	13.0	44.3										46	50				
CMV-V120TB/HNR1-B	60Hz														46	50				
CMV-V150TB/HR1-B	50Hz	15.0	51.1	17.0	58										46	50				
CMV-V150TB/HNR1-B	60Hz														46	50				

Notes: 1. Power supply: 220~240V/1PH for 50Hz; 208~230V/1PH for 60Hz
 2. Cooling test condition: indoor side 27°C DB, 19°C WB outdoor side 35°C DB. Heating test condition: indoor side 20°C DB, 15°C WB outdoor side 7°C DB
 3. Sound level: measured at a point 1 m in front of the unit at a height of 1.5 m. During actual operation, these values are normally somewhat higher as a result of ambient conditions.
 4. The above data may be changed without notice for future improvement on quality and performance.

High Static Pressure Ducted Unit



Controller			
Standard	Optional		
Wired	Wired	Wireless	Centralized

Features

Accessories

Plenum box	Air filter	EXV	Drain pump	AC Motor	DC Motor
Standard	Standard	Standard (built-in)	Optional	Standard	/

Slim body, saving suspended ceiling spaces

Slim body, saving suspended ceiling spaces.

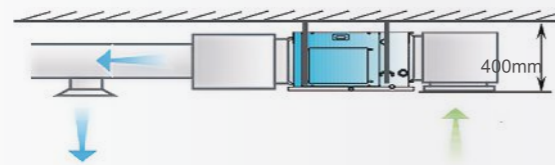

Can be used with various diffusers

Used with various diffusers, meet for different kinds of decoration.

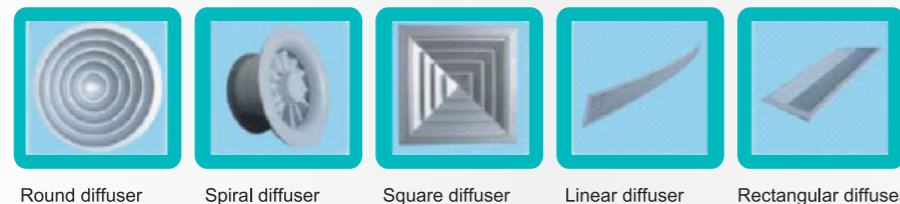

Round diffuser Spiral diffuser Square diffuser Linear diffuser Rectangular diffuser

High static pressure

Big air flow with high static pressure, easy for large rooms duct design. Suitable for different shape of rooms.

High static pressure ducted unit

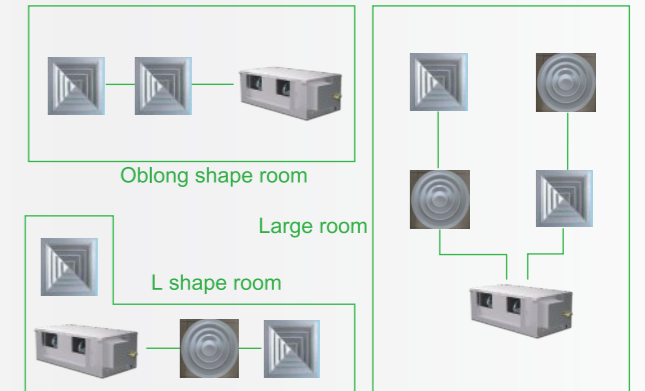
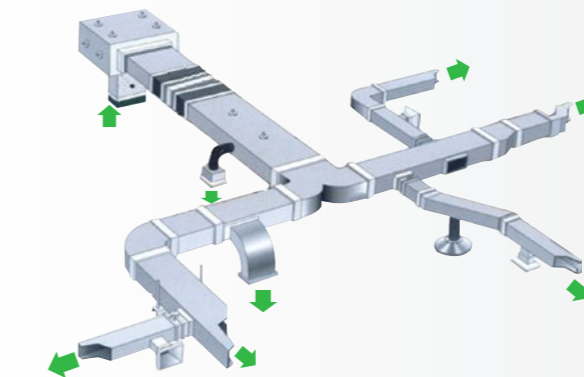

Specification

Model name	Power type	Capacity				Motor input	Air flow			Sound Level	ESP	Dimension (W×H×D)				Body Weight			Connecting pipe			Standard controller
		Cooling		Heating			m³/h	CFM	dB(A)			Packing	Body	Packing	Panel	Net	Gross	Gas	Liquid	Drain		
		kW	kBtu/h	kW	kBtu/h	kW						Pa	mm	mm	mm	mm	kg	kg	mm	mm	mm	
CMVA-V71TH/HR1-B	50Hz	7.1	24.2	7.8	26.6	0.34	1500	880	40~42	150	1490×325×720	1445×260×680	/	/	46	50	Φ15.9	Φ9.53	OD Φ25	Wired controller		
CMVA-V71TH/HNR1-B	60Hz														46	50						
CMVA-V80TH/HR1-B	50Hz	8.0	27.2	8.8	30	0.45	2300	1350	44~52	150	1245×445×655	1190×370×620	/	/	47	51	Φ15.9	Φ9.53	OD Φ25	Wired controller		
CMVA-V80TH/HNR1-B	60Hz														47	51						
CMVA-V90TH/HR1-B	50Hz	9.0	30.7	10.0	34.1	0.45	2300	1350	44~52	150	1245×445×655	1190×370×620	/	/	47	51	Φ15.9	Φ9.53	OD Φ25	Wired controller		
CMVA-V90TH/HNR1-B	60Hz														47	51						
CMVA-V100TH/HR1-B	50Hz	10.0	34.1	11.0	37.5	0.45	2300	1350	44~52	150	1245×445×655	1190×370×620	/	/	47	51	Φ15.9	Φ9.53	OD Φ25	Wired controller		
CMVA-V100TH/HNR1-B	60Hz														47	51						
CMVA-V120TH/HR1-B	50Hz	12.0	40.9	13.0	44.3	0.45	2300	1350	44~52	150	1245×445×655	1190×370×620	/	/	47	51	Φ15.9	Φ9.53	OD Φ25	Wired controller		
CMVA-V120TH/HNR1-B	60Hz														47	51						
CMVA-V150TH/HR1-B	50Hz	15.0	51.1	17.0	58.0	1.2	4000	2350	45~53	150	1510×580×870	1465×448×811	/	/	102	113	Φ22.2	Φ12.7	OD Φ30	Wired controller		
CMVA-V150TH/HNR1-B	60Hz														102	113						
CMVA-V200TH/HR1-B	50Hz	20.0	68.2	22.0	75.0	1.2	4000	2350	45~53	150	1510×580×870	1465×448×811	/	/	102	113	Φ22.2	Φ12.7	OD Φ30	Wired controller		
CMVA-V200TH/HNR1-B	60Hz														102	113						
CMVA-V250TH/HR1-B	50Hz	25.0	85.3	27.5	93.8	1.2	4400	2580	45~55	150	1510×580×870	1465×448×811	/	/	102	113	Φ22.2	Φ12.7	OD Φ30	Wired controller		
CMVA-V250TH/HNR1-B	60Hz														102	113						
CMVA-V280TH/HR1-B	50Hz	28.0	95.5	30.8	105.0	1.6	6000	3520	60	200	2267×840×1050	2165×676×916	/	/	222	260	Φ28.6	Φ15.9	OD Φ32	Wired controller		
CMVA-V280TH/HNR1-B	60Hz														222	260						
CMVA-V450TH/HZR1-B	50Hz	45.0	153.5	50.0	170.6	2.5	8000	4700	64	200	2267×840×1050	2165×676×916	/	/	222	260	Φ28.6	Φ15.9	OD Φ32	Wired controller		
CMVA-V450TH/HXR1-B	60Hz														222	260						
CMVA-V560TH/HZR1-B	50Hz	56.0	191.0	63.0	214.9	2.5	8000	4700	64	200	2267×840×1050	2165×676×916	/	/	222	260	Φ28.6	Φ15.9	OD Φ32	Wired controller		
CMVA-V560TH/HXR1-B	60Hz														222	260						

Notes: 1. 45kW & 56kW units' power supply are 380~415V/3PH for 50Hz and 208~230V/3PH for 60Hz, the others' power supply is 220~240V/1PH for 50Hz and 208~230V/1PH for 60Hz
 2. Cooling test condition: indoor side 27°C DB, 19°C WB outdoor side 35°C DB. Heating test condition: indoor side 20°C DB, 15°C WB outdoor side 7°C DB
 3. Sound level: measured at a point 1 m in front of the unit at a height of 1.5 m. During actual operation, these values are normally somewhat higher as a result of ambient conditions.
 4. The above data may be changed without notice for future improvement on quality and performance.

Wall Mounted Unit



Features

Accessories

Plenum box	Air filter	EXV	Drain pump	DC Motor
/	Standard	Standard (built-in)	/	Standard

Air supply smoothly

Cross flow fan, In Cooling mode, cold air is blown from horizontal. In heating mode, warm air is blown from vertical.

6 panels can be chosen, suitable for all kinds of decoration style

Simple, elegant, stylish, mirror design, suitable for all kinds of decoration style.

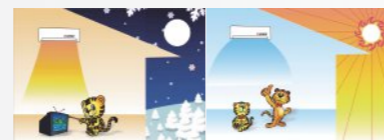

Flexible in installation

Refrigerant pipe can be connected from 3 directions.

Wide adjustable angle air supply

65°Wide angle air supply, louver angle can be fixed or set to auto-swing by controller.

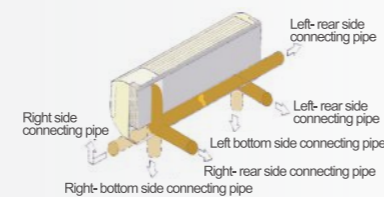

Specification

Model		CMV-D22G/HR1-C2	CMV-D28G/HR1-C2	CMV-D36G/HR1-C2	CMV-D45G/HR1-C2	CMV-D56G/HR1-C2	CMV-D71G/HR1-C2	CMV-D80G/HR1-C2	
Power Supply		220-240V/1N/50Hz	220-240V/1N/50Hz	220-240V/1N/50Hz	220-240V/1N/50Hz	220-240V/1N/50Hz	220-240V/1N/50Hz	220-240V/1N/50Hz	
Capacity	Cooling	kW	2.2	2.8	3.6	4.5	5.6	7.1	8.0
	Heating	kW	2.5	3.2	4.0	5.0	6.3	8.0	8.8
Power input		W	15	15	20	20	30	50	60
Fan motor	Type		DC	DC	DC	DC	DC	DC	DC
	Speed(Hi/Med/Low)	r/min	950/850/800	950/850/800	900/800/750	900/800/750	1100/950/850	1200/1050/900	1250/1100/950
Air flow		m3/h	410/350/330	410/350/330	640/540/520	640/540/520	800/690/600	990/850/700	1050/890/760
Sound Pressure level		dB(A)	24~33	24~33	27~36	29~38	32~42	35~43	35~46
Body dimension(W×H×D)	#170	mm	782×277×215	782×277×215	948×314×243	948×314×243	948×314×243	1050×314×246	1050×314×246
	#169	mm	782×277×205	782×277×205	948×314×239	948×314×239	948×314×239	1050×314×239	1050×314×239
	#165	mm	782×277×210	782×277×210	948×314×239	948×314×239	948×314×239	1050×314×242	1050×314×242
	Packing	mm	870×365×280	870×365×280	1045×400×330	1045×400×330	1045×400×330	1150×400×330	1150×400×330
Body weight	Net/Gross weight	kg	8.5/10	8.5/10	13/15	13/15	13/15	14.5/17	14.5/17
Refrigerant type			R410A	R410A	R410A	R410A	R410A	R410A	R410A
Throttle type			EXV	EXV	EXV	EXV	EXV	EXV	EXV
Liquid pipe/Gas pipe	mm		Ø6.35/Ø9.53	Ø6.35/Ø9.53	Ø6.35/Ø12.7	Ø6.35/Ø12.7	Ø6.35/Ø12.7	Ø9.52/Ø15.9	Ø9.52/Ø15.9
Drainage water pipe(Outer diameter)	mm		Ø20	Ø20	Ø20	Ø20	Ø20	Ø20	Ø20
Operation temperature	°C		16~32	16~32	16~32	16~32	16~32	16~32	16~32

Notes: 1. Power supply: 220~240V/1PH for 50Hz; 208~230V/1PH for 60Hz
 2. Cooling test condition: indoor side 27°C DB, 19°C WB outdoor side 35°C DB. Heating test condition: indoor side 20°C DB, 15°C WB outdoor side 7°C DB
 3. Sound level: measured at a point 1 m in front of the unit at a height of 1.5 m. During actual operation, these values are normally somewhat higher as a result of ambient conditions.
 4. The above data may be changed without notice for future improvement on quality and performance.



Floor Ceiling Unit



Controller			
Standard	Optional		
Wireless	Wireless	Wired	Centralized

Features

Accessories

Plenum box	Air filter	EXV	Drain pump	AC Motor	DC Motor
/	Standard	Standard (built-in)	Optional	Standard	/

Suspended installation, saves valuable floor space

- The use of ark effect: need to take up valuable floor position.
- The use of a hanging type indoor machine effect: Due to the adoption of a suspended installation, without occupying the ground position, will be valuable floor space to save up to add a set of dining table.

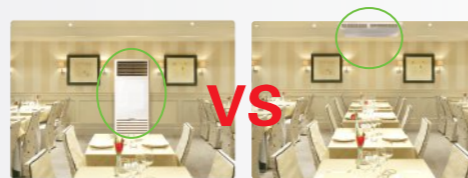

Wide angle air supply

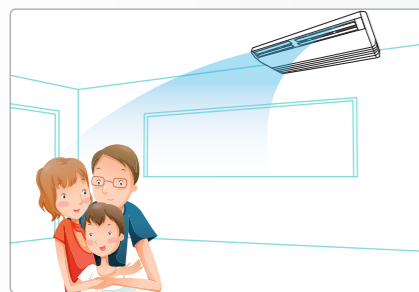

- Configured with low noise high performance centrifugal fans, has big air flow and long distance air supply.

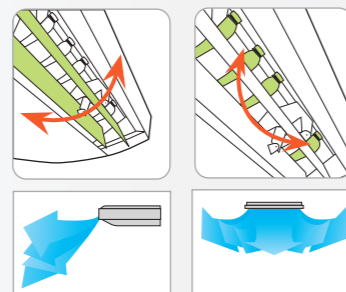

- 3 dimensional air supply, wide air supply angle, easily supply to every corners.

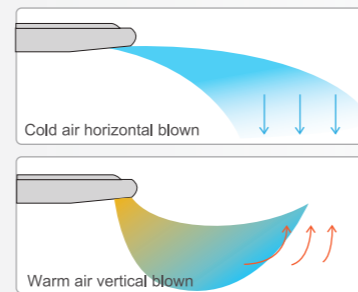

- In Cooling mode, cold air is blown from horizontal. In heating mode, warm air is blown from vertical.

Easy for installation

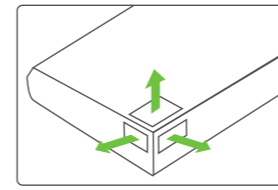

Refrigerant pipe can be connected from 3 directions.

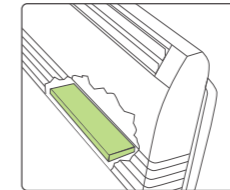

Electrical control box is in the rear of fan wheel casing, easy to remove, convenient for maintenance.

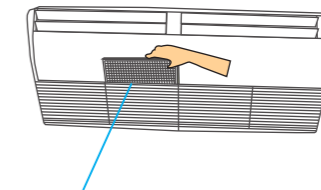

long term filter can be remove from air inlet grille to clean

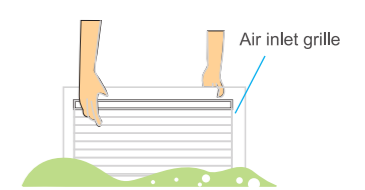

Water washable

Specification

Model name	Power type	Capacity				Motor input kW	Air flow		Sound Level dB(A)	ESP Pa	Dimension (W×H×D)				Body Weight			Connecting pipe			Standard controller							
		Cooling kW	kBtu/h	Heating kW	kBtu/h		m³/h	CFM			Packing mm	Body mm	packing mm	Panel mm	Net kg	Gross kg	Gas mm	Liquid mm	Drain mm									
CMVA45LD/HNR1-B	50Hz	4.5	15.3	5.0	17	0.06	950	550	37-46	/	1325×770×330	1245×680×240	/	/	36	42	Φ12.7	Φ6.35	OD Φ20	Remote controller								
CMVA45LD/HNR1-B	60Hz																											
CMVA56LD/HNR1-B	50Hz	5.6	19.1	6.3	21.4	0.15	1300	760	37-46																			
CMVA56LD/HNR1-B	60Hz																											
CMVA71LD/HNR1-B	50Hz	7.1	24.2	8.0	27.2	0.375	1500	880	39-48																			
CMVA71LD/HNR1-B	60Hz																											
CMVA80LD/HNR1-B	50Hz	8.0	27.2	8.8	30	0.26	2300	1350	39-48																			
CMVA80LD/HNR1-B	60Hz																											
CMVA90LD/HNR1-B	50Hz	9.0	30.7	10.0	34.1	0.26	2300	1350	44-50																			
CMVA90LD/HNR1-B	60Hz																											
CMVA112LD/HNR1-B	50Hz	11.2	38.2	12.5	42.6	0.26	2300	1350	45-52																			
CMVA112LD/HNR1-B	60Hz																											
CMVA140LD/HNR1-B	50Hz	14.0	47.7	15	51.1	0.26	2300	1350	45-52																			
CMVA140LD/HNR1-B	60Hz																											
CMVA160LD/HNR1-B	50Hz	16.0	54.5	17	58	0.26	2300	1350	45-52																			
CMVA160LD/HNR1-B	60Hz																											

Notes: 1. Power supply: 220~240V/1PH for 50Hz; 208~230V/1PH for 60Hz
 2. Cooling test condition: indoor side 27°C DB, 19°C WB outdoor side 35°C DB. Heating test condition: indoor side 20°C DB, 15°C WB outdoor side 7°C DB
 3. Sound level: measured at a point 1 m in front of the unit at a height of 1.5 m. During actual operation, these values are normally somewhat higher as a result of ambient conditions.
 4. The above data may be changed without notice for future improvement on quality and performance.



Fresh Air Processor



Controller			
Standard	Optional		
Wired	Wired	Wireless	Centralized

Features

Accessories

Plenum box	Air filter	EXV	Drain pump	AC Motor	DC Motor
Standard	Optional	Standard (built-in)	Optional	Standard	/

Healthy and comfortable

Fresh air is imported, provides a healthy and comfortable living environment.

100% Fresh air processing unit

Both fresh air filtration and heating/cooling can be achieved in a single system.

Indoor units and fresh air processing unit can be connected to the same refrigerant system, increase design flexibility and greatly reduce total system costs.

High external static pressure

External static pressure can be up to 300Pa for more flexible duct applications. The maximum distance of air supply is about 20m and the maximum height of air supply is about 6.5m.

Innovative air supply technology for excellent room temperature control

Fresh air unit can be connected with other type indoor units(only for 14/22.4/28kw fresh air unit).

Layout Example:

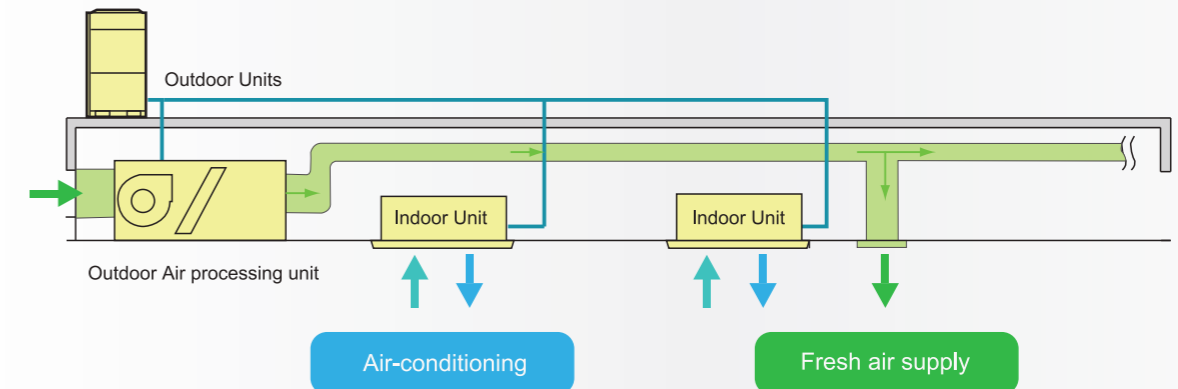

Notes: 1. When VRF system connect fresh air indoor unit and other type indoor units together, the capacity combination ratio between indoor unit and outdoor unit should within 100%.
2. Fresh air unit capacity can't bigger than 30% of total indoor units capacity.

Specification

Model name	Power type	Capacity				Motor input	Air flow	Sound Level	ESP	Dimension (W×H×D)				Body Weight		Connecting pipe			Standard controller
		Cooling		Heating						Packing	Body	packing	Panel	Net	Gross	Gas	Liquid	Drain	
		kW	kBtu/h	kW	kBtu/h														
CMVA140TF/HR1-B	50Hz	14.0	47.7	9.0	30.7	0.45	1400	820	42-48	220	1245×445×655	1190×370×620			47	51	Φ15.9	Φ9.53	Wired controller
CMVA140TF/HNR1-B	60Hz																		
CMVA224TF/HR1-B	50Hz	22.4	76.4	16.0	54.5	1.2	2000	1170	45-52	220	1510×580×870	1465×448×811			100	111	Φ22.2	Φ12.7	
CMVA224TF/HNR1-B	60Hz																		
CMVA280TF/HR1-B	50Hz	28.0	95.5	20.0	68.2	1.2	2800	1640	45-52	220	1510×580×870	1465×448×811	/	/	100	111			
CMVA280TF/HNR1-B	60Hz																		
CMVA450TF/HZR1-B	50Hz	45.0	153.5	31.4	107.1	1.6	4000	3520	58	300	2267×840×1050	2165×676×916			222	260	Φ28.6	Φ15.9	
CMVA450TF/HXR1-B	60Hz																		
CMVA560TF/HZR1-B	50Hz	56.0	191.0	39.0	133.0	2.5	6000	4700	62	300	2267×840×1050	2165×676×916			222	260			
CMVA560TF/HXR1-B	60Hz																		

Notes: 1. 45kW & 56kW units' power supply are 380~415V/3PH for 50Hz and 208~230V/3PH for 60Hz, the others' power supply is 220~240V/1PH for 50Hz and 208~230V/1PH for 60Hz
2. Cooling test condition: Indoor and outdoor side 33°C DB, 28°C WB. Heating test condition: Indoor and outdoor side 0°C DB, -2.9°C WB
3. Sound level: measured at a point 1 m in front of the unit at a height of 1.5 m. During actual operation, these values are normally somewhat higher as a result of ambient conditions.
4. The above data may be changed without notice for future improvement on quality and performance.

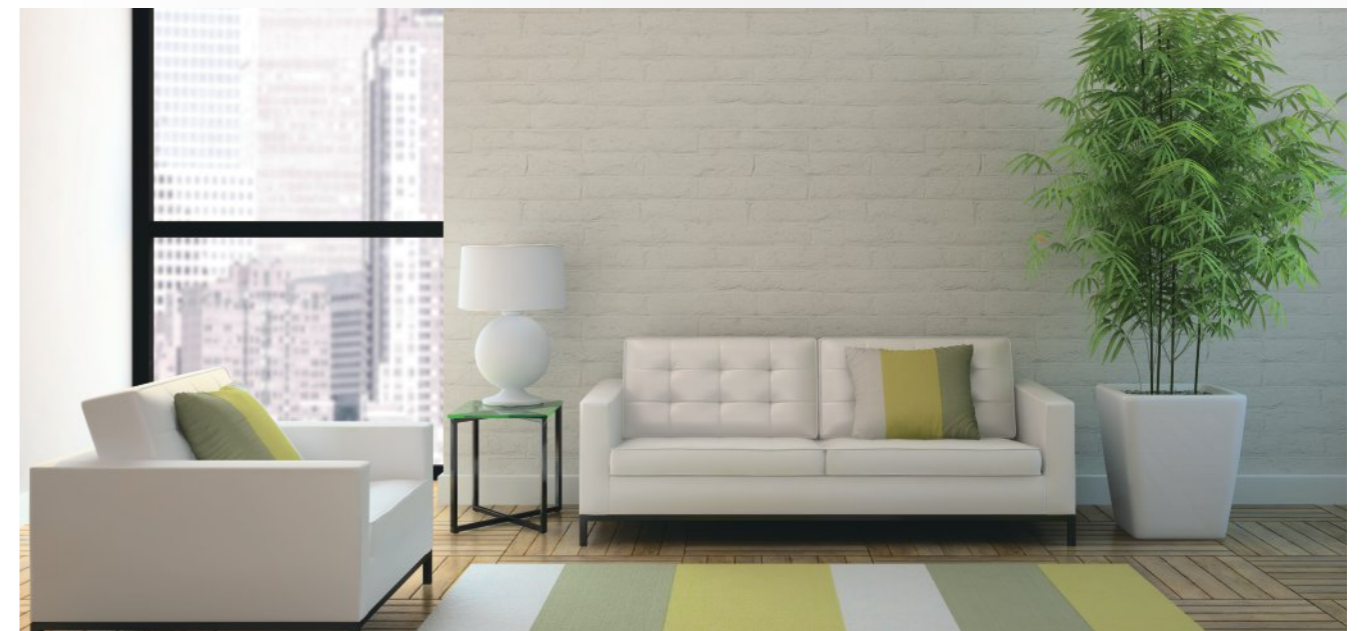

Heat Recovery Ventilator



Features

How it works

When air flow formed by exhaust air and outdoor air through the heat exchanged core in cross way, because of temperature difference in the two sides of flat partition board, the heat transmission is occurred.

In summer, outdoor air acquire cooling from air exhaust to decrease environment temperature; In winter, outdoor air acquire heating from air exhaust to increase temperature, that is to say, it realizing the energy recovery during air exhaust process to exchange the heating in heat exchanged core to outdoor air.

Application for : business office buildings, hotels, restaurants, meeting rooms, exhibition centres, leisure centres, workshop and other places.

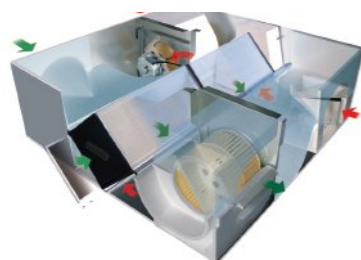
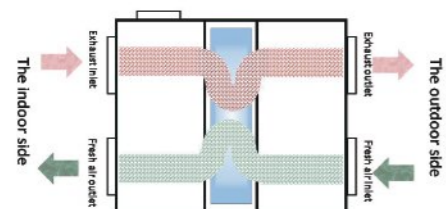

Specification

Suspended type specification

Model	Air flow	ESP	Power input	Power supply	Temperature exchanging efficiency (%)		Enthalpy exchanging efficiency (%)		Noise dB(A)	Body dimension (WxDxH) mm	Weight kg
	m ³ /h	Pa	W		Cooling	Heating	Cooling	Heating			
QR-X02D	200	75	65	220V/1PH/50Hz	60.0	65.0	50.0	55.0	30	666x580x264	25
QR-X03D	300	75	130		60.0	65.0	50.0	55.0	33	744x599x270	27
QR-X04D	400	80	200		60.0	65.0	50.0	55.0	35	744x804x270	30
QR-X05D	500	80	220		60.0	65.0	50.0	55.0	38	824x904x270	41
QR-X06D	600	90	242		60.0	65.0	50.0	55.0	40	824x904x270	42
QR-X08D	800	100	410		60.0	65.0	50.0	55.0	42	1116x884x388	68
QR-X10D	1000	150	510		60.0	65.0	50.0	55.0	43	1116x1134x388	82
QR-X13D	1300	150	530		60.0	65.0	50.0	55.0	45	1116x1134x388	82
QR-X15DS	1500	160	1000		60.0	65.0	50.0	55.0	51	1600x1200x540	200
QR-X20DS	2000	170	1200		60.0	65.0	50.0	55.0	53	1650x1400x540	225
QR-X25DS	2500	180	2000	60.0	65.0	50.0	55.0	55	1430x1610x600	240	
QR-X30DS	3000	200	2100	60.0	65.0	50.0	55.0	57	1600x1700x640	270	
QR-X40DS	4000	220	2400	60.0	65.0	50.0	55.0	60	1330x1725x1050	265	
QR-X50DS	5000	240	3000	60.0	65.0	50.0	55.0	61	1660x1820x1050	280	
QR-X60WS	6000	290	3600	60.0	65.0	50.0	55.0	70	1660x1820x1050	310	
QR-X70WS	7000	310	4200	60.0	65.0	50.0	55.0	73	2060x1660x1168	360	
QR-X80WS	8000	320	6000	60.0	65.0	50.0	55.0	74	2060x1660x1168	382	
QR-X90WS	9000	340	7500	60.0	65.0	50.0	55.0	77	2310x1900x1200	500	
QR-X100WS	10000	400	8000	60.0	65.0	50.0	55.0	78	2310x1900x1200	534	

Notes:1. Cooling test condition: indoor side 27°C DB, 19.5°C WB ; outdoor fresh air 35°C DB, 28°C;
2. Heating test condition: indoor side 21°C DB, 13°C WB outdoor fresh air 5°C DB, 2°C;
3. The above data may be changed without notice for future improvement on quality and performance.



CONTROLLERS AND SOFTWARE

Wired Controllers

- Bidirectional communication. Indoor unit's operating parameters (error code, temperature, address) can be inquired and displayed on the controller.
- Compact design
- Timer function



Touch Screen Wired Controller

- Air filter cleaning reminding function.
- Touch screen with black background and white light
- Ultra thin body and stylish design meet high-end environments.
- On/off, temperature setting, fan speed setting, mode setting, timer and check function.



Simple Centralized Controller

- Easy to install. Controller connects to outdoor units only.
- Able to install this controller after building decoration.
- 1 Controller can control max. 64 indoor units.
- Mode lock function, user can lock the running mode of indoor unit.



Wireless Remote Controllers

Wireless remote controllers

- Indoor unit address inquiry
- Indoor unit address setting
- Temperature setting
- Operation mode setting
- Fan speed setting
- Timer function



CMV-SMART (Smart Centralized Control App)

- Available on iOS and Android
- Single unit controller or group control
- Weekly schedule management
- 64 indoor unit can be controlled
- Operation parameter enquiry
- Remote control via cloud server



Touch Screen Centralized Controller

- Build in WIFI modular
- Build in Modbus protocol
- Weekly schedule management
- Operation parameter enquiry
- User friendly UI design



CHV -NET (Centralized Control System)

- Centralized control
- Electricity charge management
- Operation data record
- Schedule management

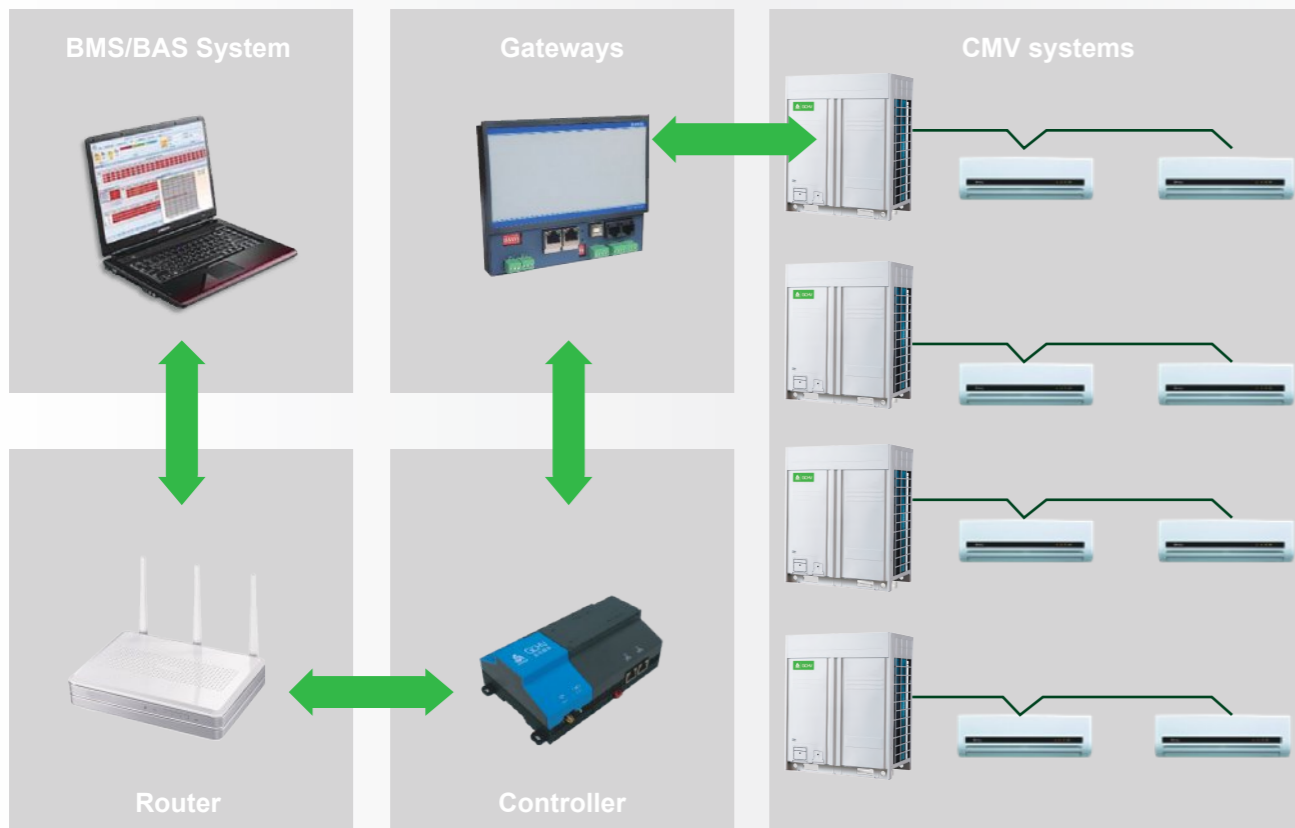

BMS Gateway

- BACnet gateway
Verified by BACnet International, fully compatible with all BACnet protocol product
- Modbus gateway
Outdoor unit built in with Modbus gateway can be customized

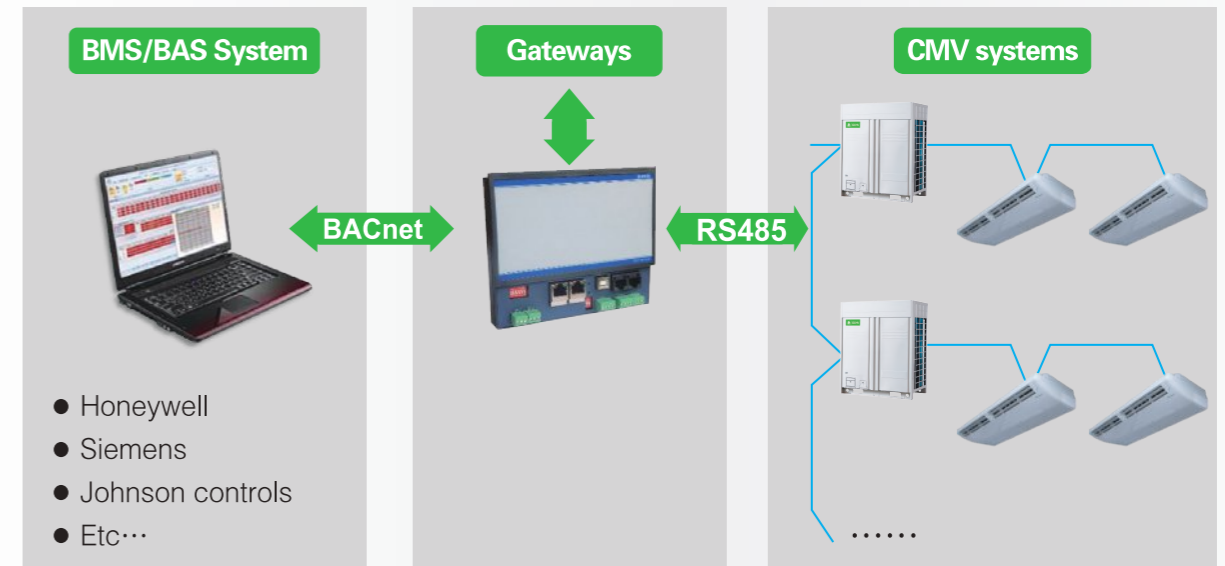

Doctor Kit Pro

- Fast to install, easy to use
- All indoor / outdoor units data can be enquired
- Indoor unit can be long distance remote controlled and diagnosed

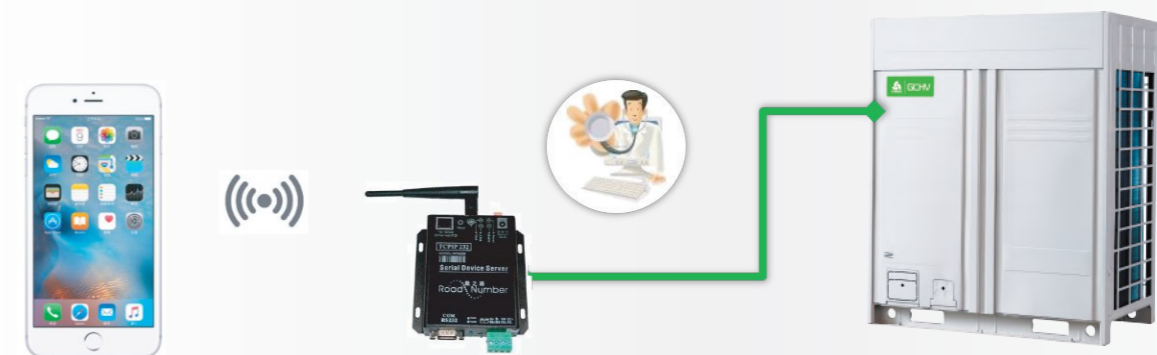

AHU Connection Kit

- Chigo AHU connection kit is an interface to allow 3rd party manufacturer's AHU connecting to Chigo VRF outdoor units.
- 4 basic modules: 5HP/10HP/20HP/30HP
- Can be combined into bigger capacity.

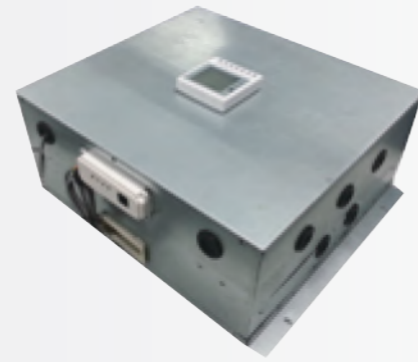

CMV outdoor unit



AHU kit

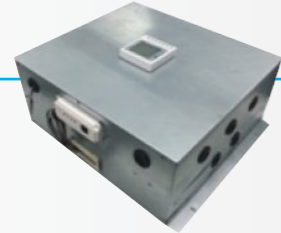

- DX type AHU
- Other supplier's indoor units



VRF Selection Software Pro

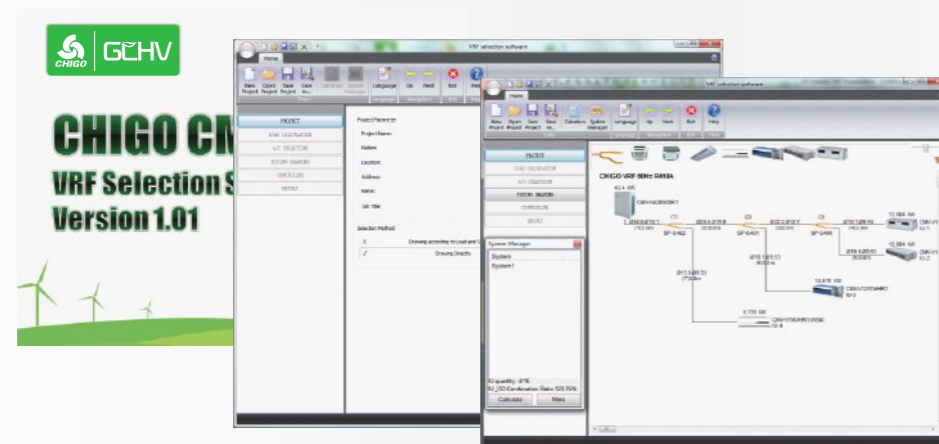

PROJECTS



Volgograd Arena, Important venue of the 2018 Russian World Cup, total VRF capacity 2400KW.



Nizhny Novgorod Stadium, Important venue of the 2018 Russian World Cup, total VRF capacity 1600KW.

PROJECTS



Main venue of the Universiade in Shenzhen, total VRF capacity 8000 kW.

PROJECTS



Mauritania International Conference Center, CMV-C & CMV-mini, total VRF capacity 3640KW.



Double Tree (Hilton) in Russia, with 3-pipe VRF system.



Montego bay resort in Jamaica, with DC inverter VRF system.